



## Natural Gas Dual Burner Station Owner's Guide



Vieluxe® Slide-In Dual Burner Station  
(Model #: 36152)



Vieluxe® Countertop Dual Burner Station  
(Model #: 37152)

### **⚠ DANGER**

If you smell gas:

1. Shut off gas to the appliance.
2. Extinguish any open flames.
3. Open lid.
4. If odor continues, keep away from the appliance and immediately call your gas supplier or your fire department.

Leaking gas may cause a fire or explosion which can cause serious bodily injury or death, or damage to property.

**⚠ WARNING:** Do not store or use gasoline or other flammable liquids or vapors within 25 feet (8m) of this appliance.

**⚠ WARNING:** Follow all leak-check procedures carefully in this manual prior to burner station operation. Do this even if burner station was dealer-assembled.

**NOTICE TO INSTALLER:** These instructions must be left with the owner and the owner should keep them for future use.

**THIS GAS APPLIANCE IS DESIGNED FOR OUTDOOR USE ONLY.**

**⚠ WARNING:** Do not try to light this appliance without reading "Lighting" instructions section of this manual.



**YOU MUST READ THIS OWNER'S GUIDE BEFORE OPERATING YOUR BURNER STATION**

## **⚠ DANGER**

**Failure to follow the Dangers, Warnings and Cautions contained in this Owner's Manual may result in serious bodily injury or death, or in a fire or an explosion causing damage to property.**

## **⚠ WARNINGS**

- ⚠ Do not store a spare or disconnected liquid propane cylinder under or near this burner station.**
- ⚠ Improper assembly may be dangerous. Please carefully follow the assembly instructions in this manual.**
- ⚠ After a period of storage, and/or non use, the Vieluxe® burner station should be checked for gas leaks and burner obstructions before use. See instructions in this manual for correct procedures.**
- ⚠ Do not operate the Vieluxe® burner station if there is a gas leak present.**
- ⚠ Do not use a flame to check for gas leaks.**
- ⚠ Combustible materials should never be within 26 inches of the top, bottom, back or sides of your Vieluxe® burner station.**
- ⚠ Do not put a burner station cover or anything flammable on, or in the storage area under the burner station.**
- ⚠ Your Vieluxe® burner station should never be used by children. Accessible parts of the burner station may be very hot. Keep young children away while it is in use.**
- ⚠ You should exercise reasonable care when operating your Vieluxe® burner station. It will be hot during cooking or cleaning and should never be left unattended, or moved while in operation.**
- ⚠ Should the burners go out while in operation, turn all gas valves off. Wait five minutes before attempting to relight, using the lighting instructions.**
- ⚠ Do not use charcoal or lava rock in your Vieluxe® burner station.**
- ⚠ Never lean over an open burner station or place hands or fingers on the front edge of the burner station.**
- ⚠ Should a grease fire occur, turn off all burners and leave lid closed until fire is out.**
- ⚠ Do not enlarge valve orifices or burner ports when cleaning the valves or burners.**
- ⚠ The Vieluxe® burner station should be thoroughly cleaned on a regular basis.**
- ⚠ Do not attempt to disconnect any gas fitting while your burner station is in operation.**
- ⚠ Use heat-resistant grill mitts or gloves when operating burner station.**
- ⚠ Keep any electrical supply cord and the fuel supply hose away from any heated surfaces.**
- ⚠ Combustion by-products produced when using this product contain chemicals known to the State of California to cause cancer, birth defects, or other reproductive harm.**
- ⚠ Do not put food directly on the burner station grates.**

# TABLE OF CONTENTS

<b>WARRANTY</b>	<b>4</b>
<b>GENERAL INSTRUCTIONS</b>	<b>5</b>
STORAGE	5
OPERATING	5
GAS SUPPLY TESTING	5
CLEANING	5
<b>LIGHTING THE LEFT &amp; RIGHT BURNERS</b>	<b>6</b>
TO EXTINGUISH	6
<b>MANUALLY LIGHTING THE LEFT &amp; RIGHT BURNERS</b>	<b>7</b>
TO EXTINGUISH	7
<b>GENERAL MAINTENANCE</b>	<b>8</b>
CHECK FOR GAS LEAKS	8
REMOVE CONTROL PANEL	8
REINSTALL CONTROL PANEL	10
REINSTALL BURNER CONTROL KNOBS & IGNITER	10
FLAME PATTERN	11
<b>REPLACE IGNITER BATTERY</b>	<b>11</b>
<b>BURNER STATION TROUBLESHOOTING</b>	<b>12</b>
<b>BURNER STATION EXPLODED VIEW</b>	<b>12</b>
<b>TRADEMARKS</b>	<b>12</b>

# WARRANTY

Weber-Stephen Products Co. (Weber-Stephen) hereby warrants to the ORIGINAL PURCHASER of this Vieluxe® appliance that it will be free of defects in material and workmanship from the date of purchase as follows:

---

- Double-Walled Stainless Steel Doors	Ltd. Lifetime
- Brushed Stainless Steel Work Surface	
- Porcelain-Enameled Cast Iron Burner Grate	

---

- Battery-Powered, Weather Sealed Continuous-Spark Igniter	10 - Year Limited
- Brass Infinite Control Valves, with Heavy-Duty Control Knobs	

---

When assembled and operated in accordance with the printed instructions accompanying it.

Weber-Stephen may require reasonable proof of your date of purchase. THEREFORE, YOU SHOULD RETAIN YOUR SALES RECEIPT OR INVOICE.

This Limited Warranty shall be limited to the repair or replacement of parts that prove defective under normal use and service and which on examination shall indicate, to Weber-Stephen's satisfaction, they are defective. Before returning any parts, contact Customer Service Toll Free at 1-866-VIELUXE<sup>SM</sup>. If Weber-Stephen confirms the defect and approves the claim, Weber-Stephen will elect to replace such parts without charge. If you are required to return defective parts, transportation charges must be prepaid. Weber-Stephen® will return parts to the purchaser, freight or postage prepaid.

This Limited Warranty does not cover any failures or operating difficulties due to accident, abuse, misuse, alteration, misapplication, vandalism, improper installation or improper maintenance or service, or failure to perform normal and routine maintenance, including but not limited to damage caused by insects within the burner tubes, as set out in this owner's manual.

Deterioration or damage due to severe weather conditions such as hail, hurricanes, earthquakes or tornadoes, discoloration due to exposure to chemicals either directly or in the atmosphere, is not covered by this Limited Warranty.

There are no other express warrants except as set forth herein and any applicable implied warranties of merchantability and fitness are limited in duration to the period of coverage of this express written Limited Warranty. Some regions do not allow limitation on how long an implied warranty lasts, so this limitation may not apply to you.

Weber-Stephen is not liable for any special, indirect or consequential damages. Some regions do not allow the exclusion or limitation of incidental or consequential damages, so this limitation or exclusion may not apply to you.

Weber-Stephen does not authorize any person or company to assume for it any other obligation or liability in connection with the sale, installation, use, removal, return, or replacement of its equipment; and no such representations are binding on Weber-Stephen.

This Warranty applies only to products sold at retail.

**Vieluxe® Customer Service**  
**1890 Roselle Road, Suite 308**  
**Schaumburg, IL 60195**  
**USA**

[www.vieluxe.com](http://www.vieluxe.com)

---

**For Replacement Parts or Service Contact Customer Service Toll Free at 1-866-VIELUXE<sup>SM</sup>.**

# GENERAL INSTRUCTIONS

- Not for use by children.
- If there are local codes that apply to gas grills, you will have to conform to them. If there are no local codes, you must conform to the latest edition of the National Fuel Gas Code: ANSI Z 223.1/NFPA 54.
- The burner station is set for operation at 4.5 inches of water column (pressure).
- This Vieluxe® burner station is designed for natural (piped in city) gas only. Do not use liquid propane (LP) bottled gas. The valves, orifices and hose are for natural gas only.
- Do not use with charcoal fuel.
- Check that the area under the control panel and the bottom tray are free from debris that might obstruct the flow of combustion or ventilation air.

## Storage

---

- The gas must be turned OFF at the natural gas supply when the Vieluxe® burner station is not in use.

## Operating

---

- ⚠ **WARNING: Only use this burner station outdoors in a well-ventilated area. Do not use in a garage, building, breezeway or any other enclosed area.**
- ⚠ **WARNING: Never use your Vieluxe® burner station under an unprotected combustible roof or overhang.**
- ⚠ **WARNING: Your Vieluxe® burner station is not intended to be installed in or on recreational vehicles and/or boats.**
- ⚠ **WARNING: Do not use combustible materials within 26 inches of the top, bottom, back or sides of the burner station.**
- ⚠ **WARNING: The entire burner station gets hot when in use. Do not leave unattended.**
- ⚠ **WARNING: Keep any electrical supply cord and the fuel supply hose away from any heated surface.**
- ⚠ **WARNING: Keep the cooking area clear of flammable vapors and liquids, such as gasoline, alcohol, etc., and combustible materials.**

## Gas Supply Testing

---

- Disconnect your Vieluxe® burner station when the gas supply is being tested at high pressures. This appliance and its individual shutoff valve must be disconnected from the gas supply piping system during any pressure testing of that system at test pressures in excess of 1/2 psig (3.5 kPa).
- Turn OFF your Vieluxe® burner station when the gas supply is being tested at low pressures. This appliance must be isolated from the gas supply piping system by closing its individual manual shutoff valve during any pressure testing of the gas supply piping system at the pressure equal to or less than 1/2 psig (3.5 kPa).

## Cleaning

---

- ⚠ **WARNING: Turn your Vieluxe® gas grill OFF and wait for it to cool before cleaning.**
- ⚠ **CAUTION: Do not clean your Flavorizer® bars or cooking grates in a self-cleaning oven. For availability of replacement cooking grates and Flavorizer® bars contact Vieluxe® Customer Service at 1-866-VIELUXE.**
- Outside surfaces** - Use a warm soapy water solution to clean, then rinse with water.
- ⚠ **CAUTION: Do not use oven cleaner, abrasive cleansers (kitchen cleansers) cleaners that contain citrus products, or abrasive cleaning pads on barbecue or cart surfaces.**
- Slide out Bottom tray** - Remove excess grease, then wash with warm soapy water, then rinse
- Flavorizer® bars and Cooking grates** - Clean with a suitable brass bristle brush. As needed, remove from grill and wash with warm soapy water, then rinse with water.
- Catch pan** - You can line the catch pan with aluminum foil. To clean the catch pan, wash with warm soapy water, then rinse.
- Thermometer** - Wipe with warm soapy water; clean with plastic scrub ball. Do not put in dishwasher or submerge in water.
- Inside cooking module** - Brush any debris off of burner tubes. DO NOT ENLARGE BURNER PORTS (OPENINGS). Wash inside of cooking box with warm soapy water and a water rinse.
- Inside Lid** - While lid is warm, wipe inside with paper towel to prevent grease build-up. Flaking built-up grease resembles paint flakes.
- Stainless steel surfaces** - Wash with a soft cloth and a soap and water solution. Be careful to scrub with the grain direction of the stainless steel.

# LIGHTING THE LEFT & RIGHT BURNERS

Summary lighting instructions are located on the inside of the burner station lid.

**⚠DANGER:** Both burner valves must be in the OFF position before turning on the gas supply. If the valves are not in the OFF position, gas will flow to the burners. This condition can cause a fire or explosion resulting in serious bodily injury or death.

**⚠WARNING:** Check hose before each use of grill for nicks, cracking, abrasions or cuts. If the hose is found to be damaged in any way, do not use the grill. Replace using only **Vieluxe®** authorized replacement hose. Contact **Vieluxe®** Customer Service at 1-866-VIELUXE.

- 1** Make sure all burner control knobs are turned OFF. (Push control knob in and turn clockwise to ensure that it is in the OFF position.)
- 2** Lift the cover to fully open before attempting to light the left or right burner.
- 3** Turn on the gas supply and select which burner(s) you are going to use.

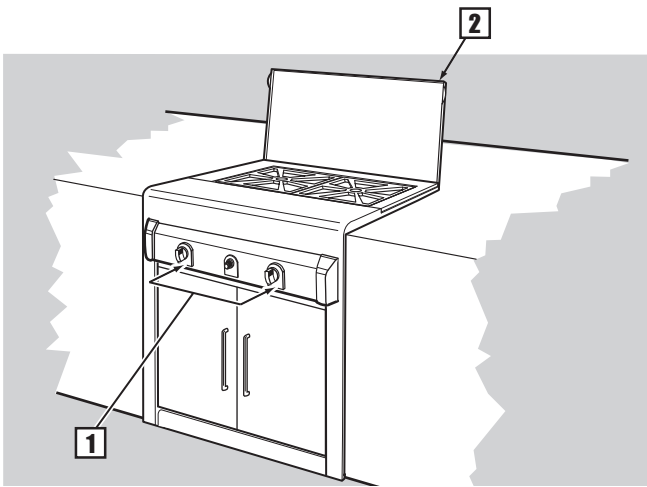

**Vieluxe® Slide-In Dual Burner Station**

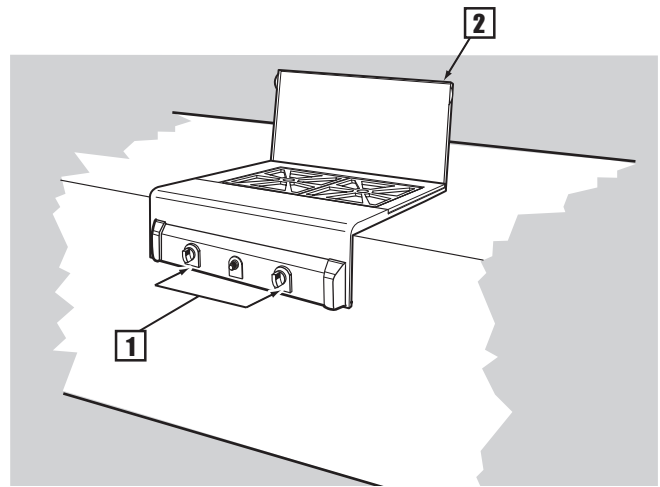

**Vieluxe® Countertop Dual Burner Station**

**⚠WARNING:** Do not lean over the open burners.

- 4** Push burner control knob in and turn to HI/START.
- 5** Push and hold down the Igniter button until burner ignites. You will hear the igniter sparking.
- 6** Check that the burner is lit by looking down through the burner grates.

**⚠DANGER:** If the burner does not light, turn the burner control knob to OFF and wait 5 minutes to let the gas clear before you try again or try to light with a match.

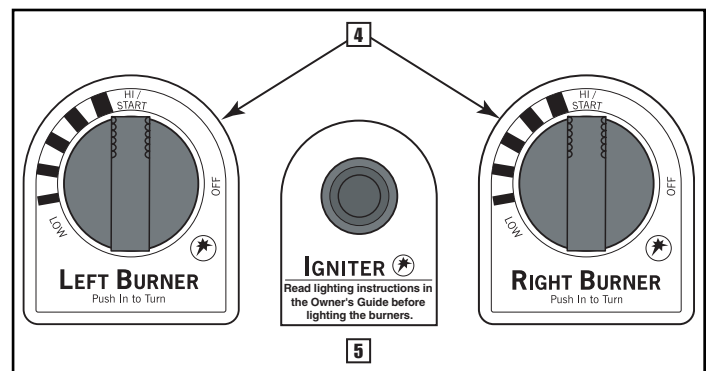

**⚠CAUTION:** Burners and grates must be cool before closing burner station cover.

## To extinguish

**⚠DANGER:** Push in and turn each burner control knob clockwise to OFF position. Turn gas supply OFF at the source.

# MANUALLY LIGHTING THE LEFT & RIGHT BURNERS

Summary lighting instructions are located on the inside of the burner station lid.

**⚠DANGER:** Both burners valves must be in the OFF position before turning on gas supply. If the valves are not in the OFF position, gas will flow to the burners. This condition can cause a fire or explosion resulting in serious bodily injury or death.

**⚠WARNING:** Check hose before each use of grill for nicks, cracking, abrasions or cuts. If the hose is found to be damaged in any way, do not use the grill. Replace using only Vieluxe® authorized replacement hose. Contact Vieluxe® Customer Service at 1-866-VIELUXE.

- 1** Make sure all burner control knobs are turned OFF. (Push control knob in and turn clockwise to ensure that it is in the OFF position.)
- 2** Lift the cover to fully open before attempting to light the left or right burner.
- 3** Turn on the gas supply and select which burner(s) you are going to use.

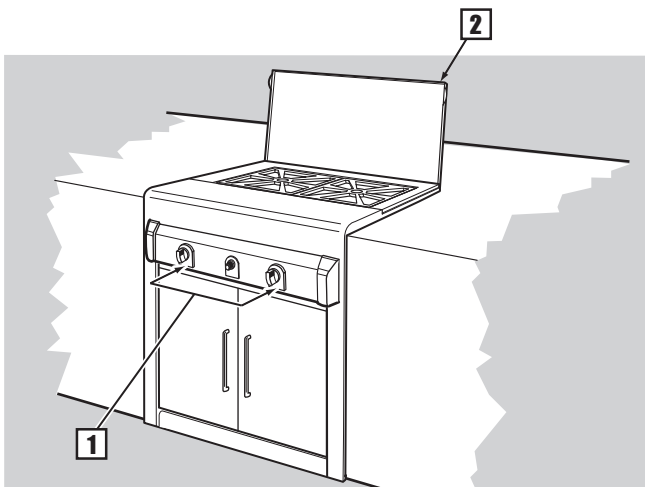

Vieluxe® Slide-In Dual Burner Station

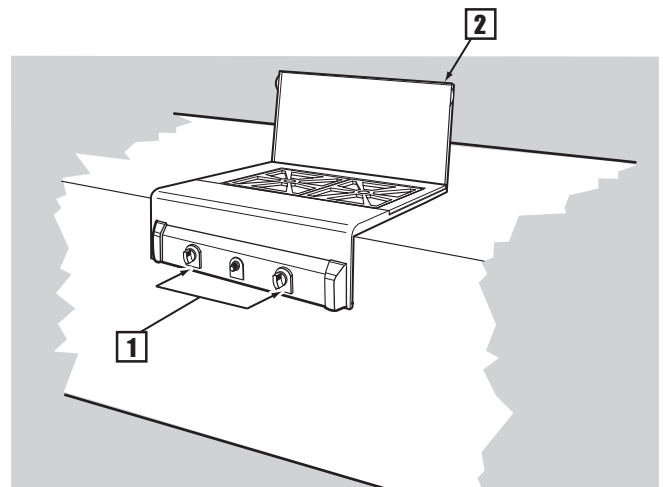

Vieluxe® Countertop Dual Burner Station

- 4** Put a match in the match holder and strike the match.
- 5** Insert match holder and lit match down through burner grate to desired burner.

**⚠WARNING:** Do not lean over the open burners while manually lighting.

- 6** Push burner control knob in and turn to HI / START.
- 7** Check that the burner is lit by looking down through the burner grates.

**⚠WARNING:** If the burner does not light, turn the burner control knob to OFF and wait 5 minutes to let the gas clear before you try again.

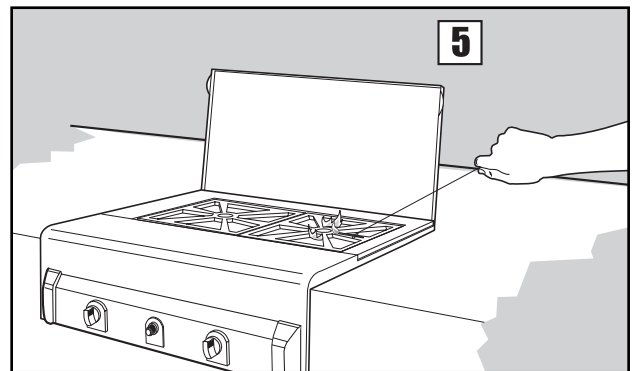

## To extinguish

Push down and turn each burner control knob clockwise to OFF position. Turn gas supply OFF at the source.

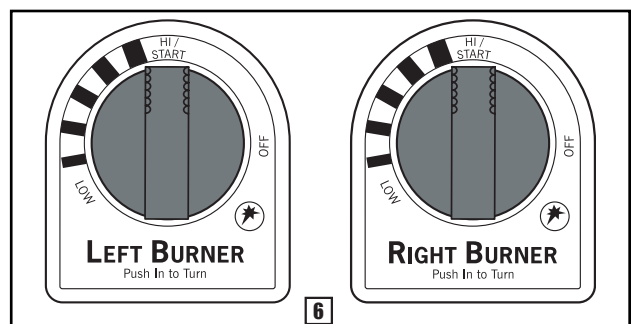

# GENERAL MAINTENANCE

## Check for gas leaks

### **⚠ WARNING**

The gas connections of your Vieluxe® burner station have been factory tested. We do however recommend that you leak check all gas connections before operating your Vieluxe® burner station.

## Remove control panel

*Tool required: Screwdriver*

Remove the burner control knobs (1). Unscrew the igniter button and nut from the igniter base (2). The screws (3) need to be removed from the control panel (4) before the control panel is removed from the burner station.

**Slide-In Burner Station**

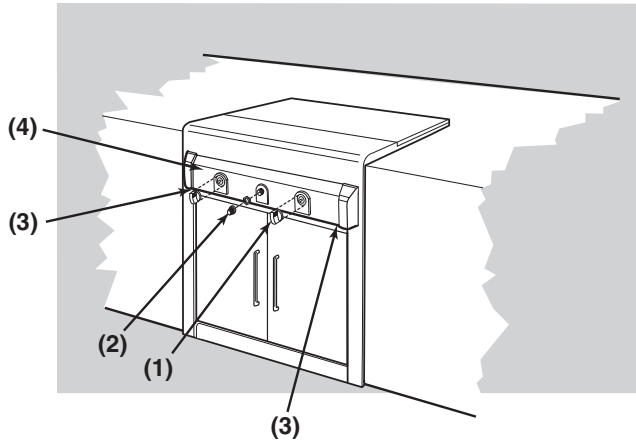

**Countertop Burner Station**

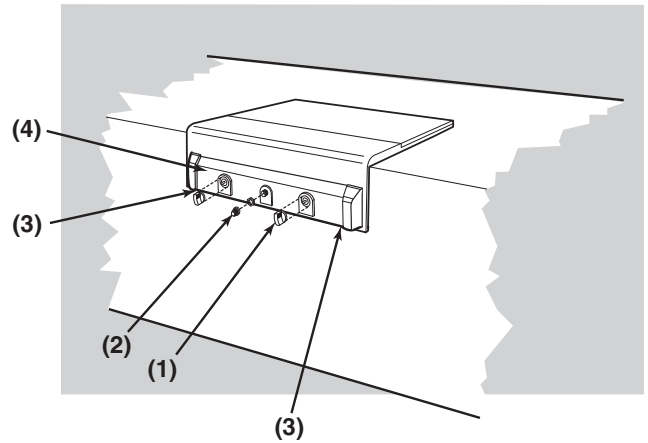

Put your fingers under the front edge of the control panel and lift off.

**Slide-In Burner Station**

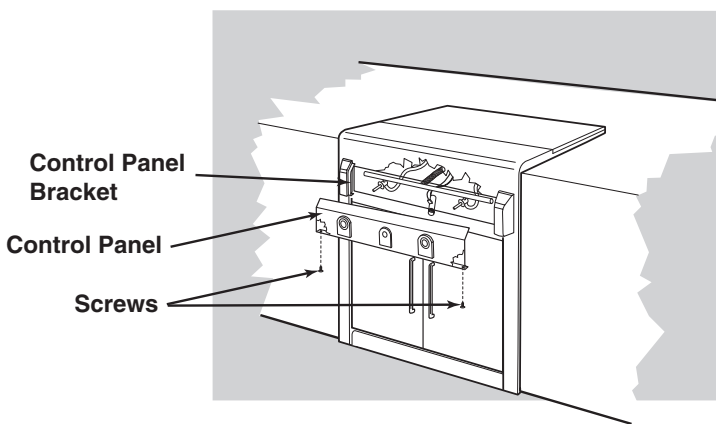

**Countertop Burner Station**

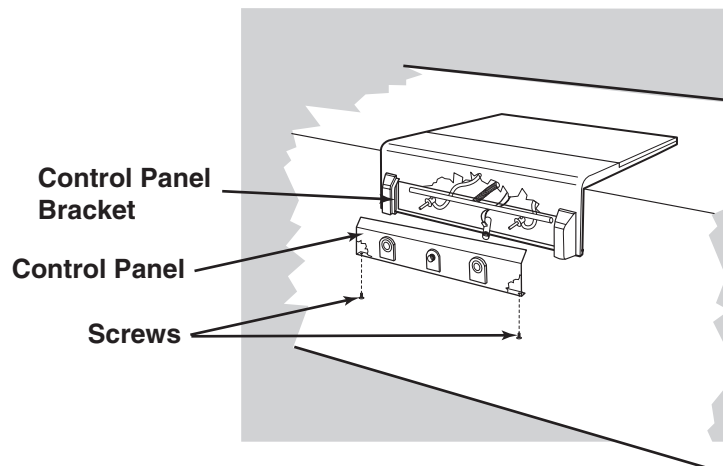

# GENERAL MAINTENANCE

Completely remove the control panel from the cooking box assembly exposing the valves, burners, igniters, and manifold.

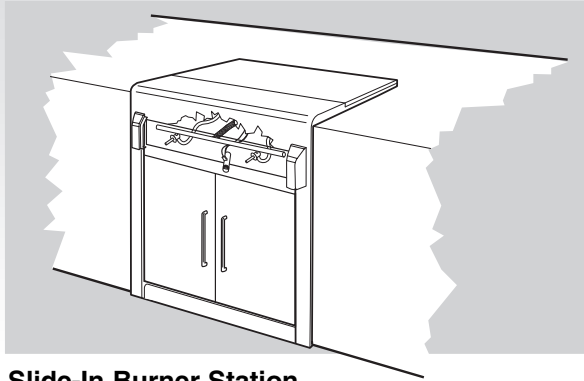

Slide-In Burner Station

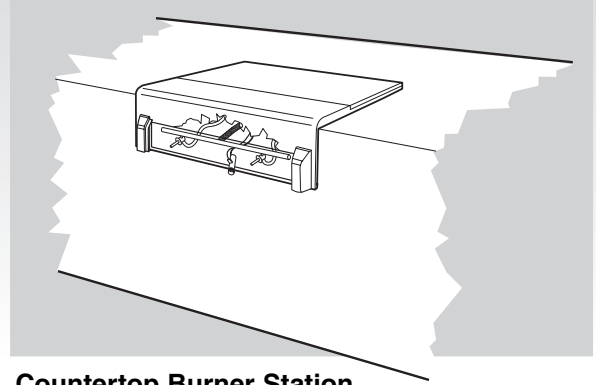

Countertop Burner Station

## ⚠ DANGER

**Do not use an open flame to check for gas leaks. Be sure there are no sparks or open flames in the area while you check for leaks. This will result in a fire or explosion which can cause serious bodily injury or death and damage to property.**

**⚠WARNING:** You should check for gas leaks every time you disconnect and reconnect a gas fitting.

Parts required: a soap and water solution and a rag or brush to apply it.

*Note: Since some leak test solutions, including soap and water, may be slightly corrosive, all connections should be rinsed with water after checking for leaks.*

**⚠WARNING:** Make sure all burner control knobs are in the OFF position.

1) Turn on the gas supply.

Check for leaks by wetting the connections with the soap and water solution and watching for bubbles. If bubbles form or if a bubble grows there is a leak.

**⚠WARNING:** Do not ignite burners while checking for leaks.

Check:

- a) Valve to manifold connections.
- b) Burner lines to valve connections.
- c) Gas lines to manifold connections.

**⚠WARNING:** If there is a leak at valve to manifold connection (a), burner lines to valve connections (b), or gas line to manifold connection (c), turn OFF the gas and retighten the fitting with a wrench and recheck for leaks with a soap and water solution.

If a leak persists after retightening the fitting, turn OFF the gas. **DO NOT OPERATE THE BURNER STATION.** Contact your dealer.

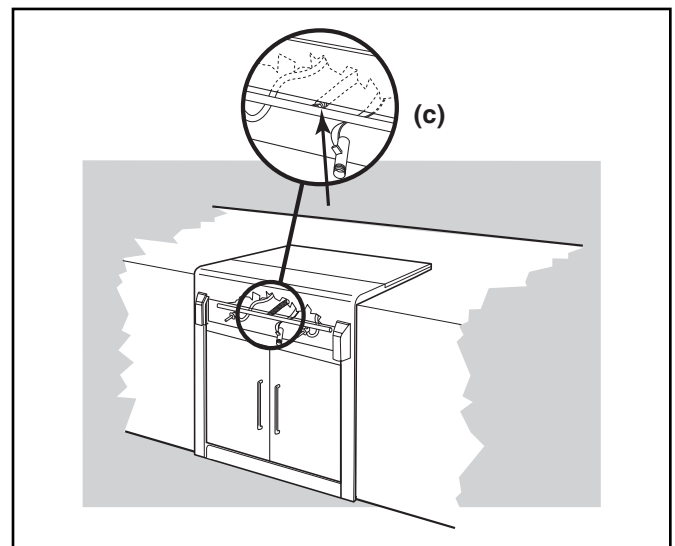
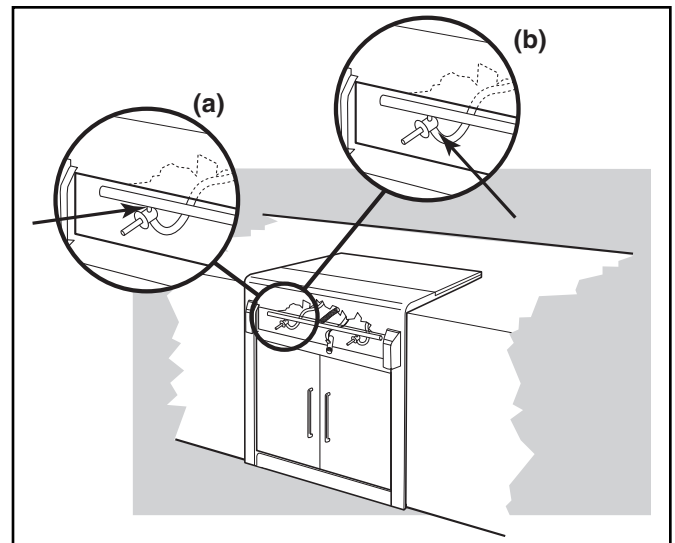

# GENERAL MAINTENANCE

## Reinstall control panel

*Parts required: control panel, screws, and burner control knobs.*

Place the control panel back onto the control panel brackets on either side of the front of the burner station.

Line up screws with screw holes on both the control panel and control panel brackets. Tighten screws.

**Slide-In Burner Station**

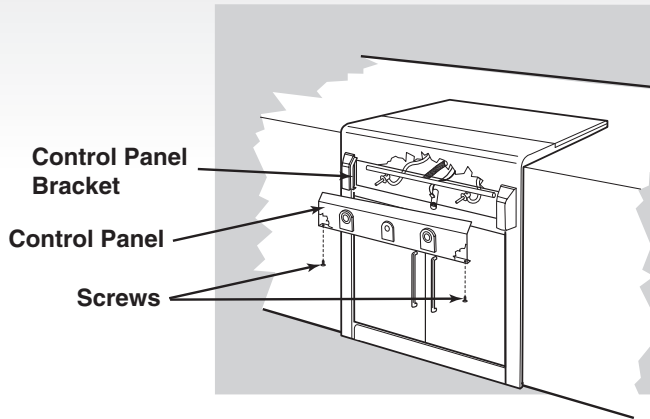

**Countertop Burner Station**

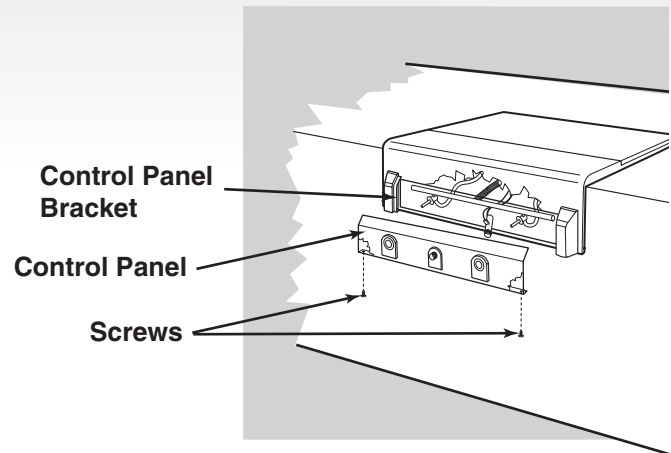

## Reinstall burner control knobs & igniter wires

*You will need: 2 control knobs, Igniter button and igniter nut.*

Place control knobs(1) in through the bezels onto the valve stems. Push the igniter(4) through the control panel so that the threads appear, replace the igniter nut(3) and the igniter button(2).

*You will need: 2 control knobs, Igniter button and igniter nut.*

Place control knobs(1) in through the bezels onto the valve stems. Push the igniter(4) through the control panel so that the threads appear, replace the igniter nut(3) and the igniter button(2).

**Slide-In Burner Station**

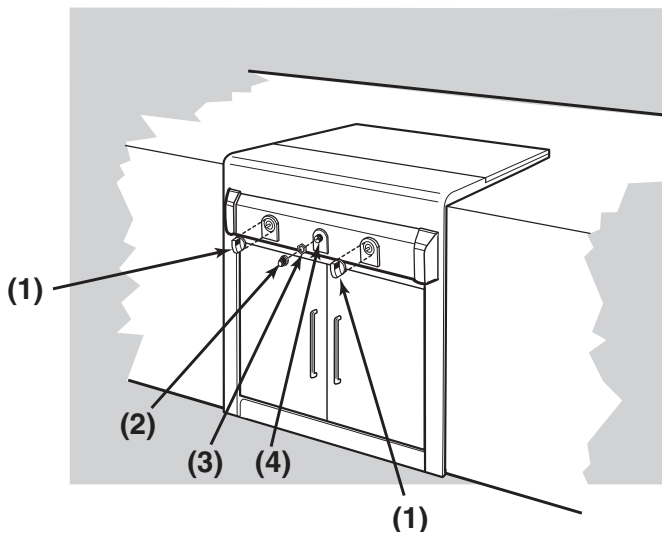

**Countertop Burner Station**

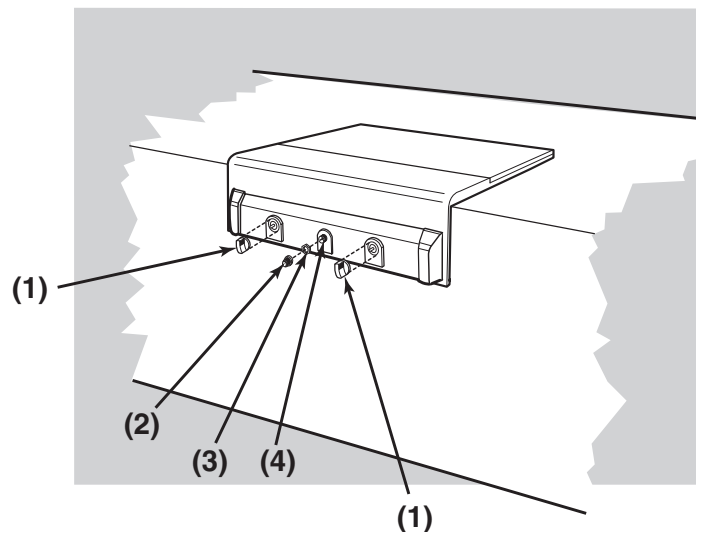

# GENERAL MAINTENANCE

## Flame pattern

The Vieluxe® burners have been factory set for the correct air and gas mixture. The correct flame pattern is shown at right.

- 1) Burner tube
- 2) Tips occasionally flicker yellow
- 3) Light blue
- 4) Dark blue

Check that all burner components are in place. Check that the orifice is not obstructed.

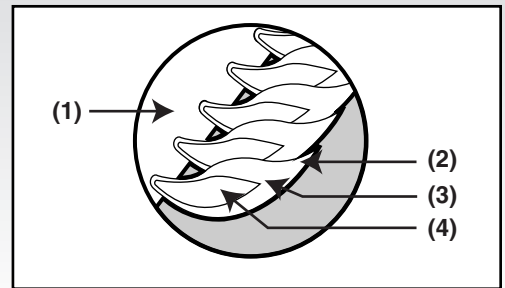

## Replace igniter battery

*Parts required: 1 AA alkaline battery.*

Unscrew igniter button from front of control panel. Remove igniter button and contact spring. Remove old battery and replace with a new AA alkaline battery. Positive end of battery faces out as shown in illustration. Replace spring contact and screw igniter button back in.

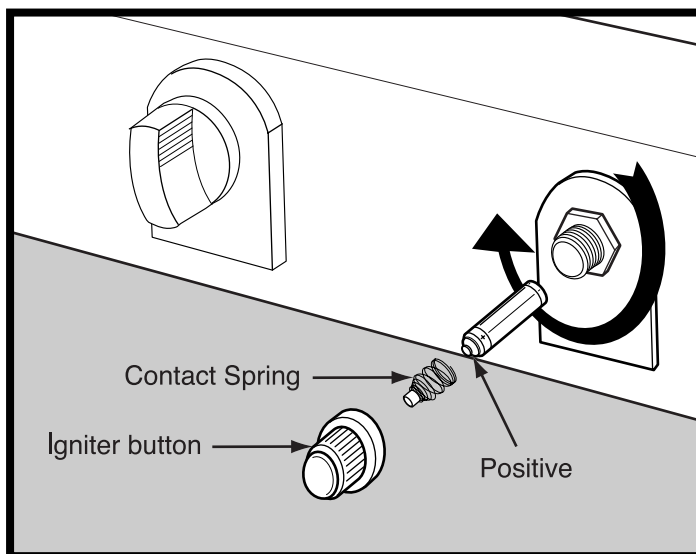

# SIDE BURNER TROUBLESHOOTING

**⚠WARNING:** Before attempting any troubleshooting steps, all gas controls and supply valves should be in the OFF position.

Problem	Check	Cure
Burner does not light.	Is gas supply off?	Turn supply on.
Flame is low in HIGH position.	Is fuel hose bent or kinked?	Straighten hose.
Flame is very yellow in conjunction with the smell of gas,  OR  Burner makes popping noise in conjunction with the smell of gas.	Inspect burner ring slots for obstructions.  Inspect burner base for obstructions.	Clean if necessary.
Push button ignition does not work.	Does burner light with a match?	If match lights burner, check igniter (see page 11).
Burner flame very large and yellow.	Is burner ring properly installed?	Reseat burner ring.

If problems cannot be corrected by using these methods, please contact Customer Service toll free at 1-866-VIELUXE<sup>SM</sup>.

## BURNER STATION EXPLODED VIEW

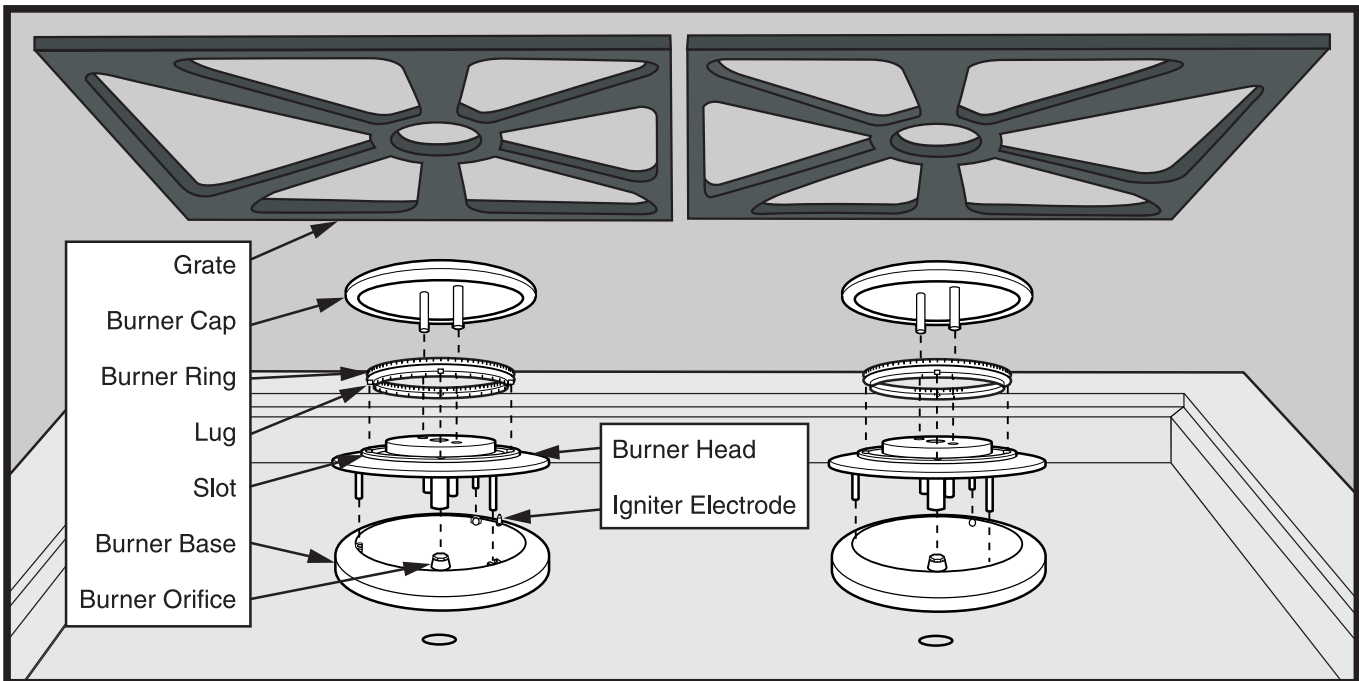

Burner assembly consists of: Burner cap, burner ring, burner head, and burner base.