



## Built-In Natural Gas Grill Owner's Guide



Vieluxe® 27" Built-In Grill  
(Model #: 360152)



Vieluxe® 39" Built-In Grill  
(Model #: 370152)

### **⚠ DANGER**

If you smell gas:

1. Shut off gas to the appliance.
2. Extinguish any open flames.
3. Open lid.
4. If odor continues, keep away from the appliance and immediately call your gas supplier or your fire department.

Leaking gas may cause a fire or explosion which can cause serious bodily injury or death, or damage to property.

**⚠ WARNING:** Do not store or use gasoline or other flammable liquids or vapors within 25 feet (8m) of this appliance.

**⚠ WARNING:** Follow all leak-check procedures carefully in this manual prior to grill operation. Do this even if grill was dealer-assembled.

**NOTICE TO INSTALLER:** These instructions must be left with the owner and the owner should keep them for future use.

**THIS GAS APPLIANCE IS DESIGNED FOR OUTDOOR USE ONLY.**

**⚠ WARNING:** Do not try to light this appliance without reading "Lighting" instructions section of this manual.



**YOU MUST READ THIS OWNER'S GUIDE BEFORE OPERATING YOUR GAS GRILL**

## **⚠DANGER**

**Failure to follow the Dangers, Warnings and Cautions contained in this Owner's Manual may result in serious bodily injury or death, or in a fire or an explosion causing damage to property.**

## **⚠WARNINGS**

- ⚠ Do not store a spare or disconnected liquid propane cylinder under or near this grill.
- ⚠ Improper assembly may be dangerous. Please carefully follow the assembly instructions in this manual.
- ⚠ After a period of storage, and/or non use, the Vieluxe® gas grill should be checked for gas leaks and burner obstructions before use. See instructions in this manual for correct procedures.
- ⚠ Do not operate the Vieluxe® gas grill if there is a gas leak present.
- ⚠ Do not use a flame to check for gas leaks.
- ⚠ Combustible materials should never be within 26 inches of the top, bottom, back or sides of your Vieluxe® gas grill.
- ⚠ Do not put a grill cover or anything flammable on, or in the storage area under the grill.
- ⚠ Your Vieluxe® gas grill should never be used by children. Accessible parts of the grill may be very hot. Keep young children away while it is in use.
- ⚠ You should exercise reasonable care when operating your Vieluxe® gas grill. It will be hot during cooking or cleaning and should never be left unattended, or moved while in operation.
- ⚠ Should the burners go out while in operation, turn all gas valves off. Open the lid and wait five minutes before attempting to relight, using the lighting instructions.
- ⚠ Do not use charcoal or lava rock in your Vieluxe® gas grill.
- ⚠ Never lean over open grill or place hands or fingers on the front edge of the cook box.
- ⚠ Should a grease fire occur, turn off all burners and leave lid closed until fire is out.
- ⚠ Do not enlarge valve orifices or burner ports when cleaning the valves or burners.
- ⚠ The Vieluxe® gas grill should be thoroughly cleaned on a regular basis.
- ⚠ Liquid propane gas is not natural gas. The conversion or attempted use of natural gas in a liquid propane unit or liquid propane gas in a natural gas unit is dangerous and will void your warranty.
- ⚠ Do not attempt to disconnect any gas fitting while your grill is in operation.
- ⚠ Use heat-resistant grill mitts or gloves when operating grill.
- ⚠ Combustion by-products produced when using this product contain chemicals known to the State of California to cause cancer, birth defects, or other reproductive harm.

# TABLE OF CONTENTS

<b>WARRANTY</b>	<b>4</b>	<b>BURNER SET TROUBLESHOOTING</b>	<b>26</b>
<b>GENERAL INSTRUCTIONS</b>	<b>5</b>	<b>ROTISSERIE BURNER TROUBLESHOOTING</b>	<b>27</b>
STORAGE	5	<b>VIELUXE® GRILLING METHODS</b>	<b>28</b>
OPERATING	5	PREHEATING	29
GAS SUPPLY TESTING	5	COVERED COOKING	29
CLEANING	5	DIRECT COOKING	30
<b>LIGHTING THE MAIN BURNERS</b>	<b>6</b>	INDIRECT COOKING	30
CROSSOVER® IGNITION SYSTEM	6	<b>GRILLING TIPS &amp; HELPFUL HINTS</b>	<b>31</b>
TO EXTINGUISH	7	<b>FOOD HANDLING SAFETY</b>	<b>31</b>
<b>MANUALLY LIGHTING THE MAIN BURNERS</b>	<b>8</b>	<b>STORAGE</b>	<b>32</b>
CROSSOVER® IGNITION SYSTEM	8	<b>CLEANING</b>	<b>32</b>
TO EXTINGUISH	9	<b>GRILLING GUIDE</b>	<b>33</b>
<b>USING THE VIELUXE® SMOKER</b>	<b>10</b>	BEEF	33
TO USE THE VIELUXE® SMOKER	10	LAMB	33
<b>LIGHTING THE SMOKER BURNER</b>	<b>11</b>	GAME	34
TO EXTINGUISH	11	PORK	34
<b>MANUALLY LIGHTING THE SMOKER BURNER</b>	<b>12</b>	POULTRY	34
TO EXTINGUISH	13	FISH & SEAFOOD	35
<b>ROTISSERIE ASSEMBLY</b>	<b>14</b>	FRUIT	35
<b>USING THE VIELUXE® ROTISSERIE</b>	<b>15</b>	VEGETABLES	36
IMPORTANT SAFEGUARDS	15	<b>TRADEMARKS</b>	<b>36</b>
OPERATING	16		
COOKING	16		
<b>LIGHTING THE ROTISSERIE BURNER</b>	<b>17</b>		
TO EXTINGUISH	17		
<b>MANUALLY LIGHTING THE ROTISSERIE BURNER</b>	<b>18</b>		
TO EXTINGUISH	18		
<b>GENERAL MAINTENANCE</b>	<b>19</b>		
CHECK FOR GAS LEAKS	19		
REMOVE CONTROL PANEL	19		
REINSTALL CONTROL PANEL	21		
REINSTALL BURNER CONTROL KNOBS & IGNITER WIRES	21		
SPIDER/INSECT SCREENS	22		
INSPECTION AND CLEANING OF THE SPIDER/INSECT SCREENS	22		
MAIN BURNER FLAME PATTERN	23		
MAIN BURNER CLEANING PROCEDURE	23		
REPLACING MAIN BURNERS	24		
CROSSOVER® IGNITION SYSTEM OPERATIONS	25		
REPLACE IGNITER BATTERIES	25		

# WARRANTY

Weber-Stephen Products Co. (Weber-Stephen) hereby warrants to the ORIGINAL PURCHASER of this Vieluxe® gas grill that it will be free of defects in material and workmanship from the date of purchase as follows:

- Double-Walled Stainless Steel Hood with Stainless Steel End Caps	Ltd. Lifetime
- Double-Walled Stainless Steel Doors	
- Infrared Rear Rotisserie Burner	
- 18SR Smoker Burner	
- Porcelain-Enameled Cast Iron Side Burner Grate	
- 18SR Stainless Steel Primary Burners	
<hr/>	
- Heavy-Duty Stainless Steel Flavorizer® Bars	25 - Year Limited
- Heavy-Duty 3/8" Welded Rod Stainless Steel Cooking Grates	
<hr/>	
- Battery-Powered, Weather Sealed Continuous-Spark Igniter	10 - Year Limited
- Brass Infinite Control Valves, with Heavy-Duty Control Knobs	
<hr/>	

When assembled and operated in accordance with the printed instructions accompanying it.

Weber-Stephen may require reasonable proof of your date of purchase. THEREFORE, YOU SHOULD RETAIN YOUR SALES RECEIPT OR INVOICE.

This Limited Warranty shall be limited to the repair or replacement of parts that prove defective under normal use and service and which on examination shall indicate, to Weber-Stephen's satisfaction, they are defective. Before returning any parts, contact Customer Service Toll Free at 1-866-VIELUXE<sup>SM</sup>. If Weber-Stephen confirms the defect and approves the claim, Weber-Stephen will elect to replace such parts without charge. If you are required to return defective parts, transportation charges must be prepaid. Weber-Stephen will return parts to the purchaser, freight or postage prepaid.

This Limited Warranty does not cover any failures or operating difficulties due to accident, abuse, misuse, alteration, misapplication, vandalism, improper installation or improper maintenance or service, or failure to perform normal and routine maintenance, including but not limited to damage caused by insects within the burner tubes, as set out in this owner's manual.

Deterioration or damage due to severe weather conditions such as hail, hurricanes, earthquakes or tornadoes, discoloration due to exposure to chemicals either directly or in the atmosphere, is not covered by this Limited Warranty.

There are no other express warrants except as set forth herein and any applicable implied warranties of merchantability and fitness are limited in duration to the period of coverage of this express written Limited Warranty. Some regions do not allow limitation on how long an implied warranty lasts, so this limitation may not apply to you.

Weber-Stephen is not liable for any special, indirect or consequential damages. Some regions do not allow the exclusion or limitation of incidental or consequential damages, so this limitation or exclusion may not apply to you.

Weber-Stephen does not authorize any person or company to assume for it any other obligation or liability in connection with the sale, installation, use, removal, return, or replacement of its equipment; and no such representations are binding on Weber-Stephen.

This Warranty applies only to products sold at retail.

**Vieluxe® Customer Service**  
**1890 Roselle Road, Suite 308**  
**Schaumburg, IL 60195**  
**USA**

[www.vieluxe.com](http://www.vieluxe.com)

**For Replacement Parts or Service Contact Customer Service Toll Free at 1-866-VIELUXE<sup>SM</sup>.**

# GENERAL INSTRUCTIONS

- These instructions will give you the minimum requirements for assembling your Vieluxe® gas grill. Please read the instructions carefully before using your Vieluxe® gas grill. Improper assembly can be dangerous.
- Not for use by children.
- If there are local codes that apply to portable gas grills, you will have to conform to them. If there are no local codes, you must conform to the latest edition of the National Fuel Gas Code: ANSI Z 223.1/NFPA 54.
- The regulator must be set for 4.5 inches of water column pressure.
- This Vieluxe® gas grill is designed for natural (piped in city) gas only. Do not use liquid propane (LP) bottled gas. The valves, orifices and hose are for natural gas only.
- Do not use with charcoal fuel.
- Check that the area under the control panel and the bottom tray are free from debris that might obstruct the flow of combustion or ventilation air.

## Storage

---

- The gas must be turned OFF at the natural gas supply when the Vieluxe® gas grill is not in use.

## Operating

---

- ⚠ **WARNING: Only use this grill outdoors in a well-ventilated area. Do not use in a garage, building, breezeway or any other enclosed area.**
- ⚠ **WARNING: Never use your Vieluxe® gas grill under an unprotected combustible roof or overhang.**
- ⚠ **WARNING: Your Vieluxe® gas grill is not intended to be installed in or on recreational vehicles and/or boats.**
- ⚠ **WARNING: Do not use combustible materials within 26 inches of the top, bottom, back or sides of the grill.**
- ⚠ **WARNING: The entire cooking box gets hot when in use. Do not leave unattended.**
- ⚠ **WARNING: Keep any electrical supply cord and the fuel supply hose away from any heated surface.**
- ⚠ **WARNING: Keep the cooking area clear of flammable vapors and liquids, such as gasoline, alcohol, etc., and combustible materials.**

## Gas Supply Testing

---

- Disconnect your Vieluxe® gas grill when the gas supply is being tested at high pressures. This appliance and its individual shutoff valve must be disconnected from the gas supply piping system during any pressure testing of that system at test pressures in excess of 1/2 psig (3.5 kPa).
- Turn OFF your Vieluxe® gas grill when the gas supply is being tested at low pressures. This appliance must be isolated from the gas supply piping system by closing its individual manual shutoff valve during any pressure testing of the gas supply piping system at the pressure equal to or less than 1/2 psig (3.5 kPa).

## Cleaning

---

- ⚠ **WARNING: Turn your Vieluxe® gas grill OFF and wait for it to cool before cleaning.**
- ⚠ **CAUTION: Do not clean your Flavorizer® bars or cooking grates in a self-cleaning oven. For availability of replacement cooking grates and Flavorizer® bars contact Vieluxe® Customer Service at 1-866-VIELUXE.**
- Outside surfaces** - Use a warm soapy water solution to clean, then rinse with water.
- ⚠ **CAUTION: Do not use oven cleaner, abrasive cleansers (kitchen cleansers) cleaners that contain citrus products, or abrasive cleaning pads on barbecue or cart surfaces.**
- Slide out Bottom tray** - Remove excess grease, then wash with warm soapy water, then rinse
- Flavorizer® bars and Cooking grates** - Clean with a suitable brass bristle brush. As needed, remove from grill and wash with warm soapy water, then rinse with water.
- Catch pan** - You can line the catch pan with aluminum foil. To clean the catch pan, wash with warm soapy water, then rinse.
- Thermometer** - Wipe with warm soapy water; clean with plastic scrub ball. Do not put in dishwasher or submerge in water.
- Inside cooking module** - Brush any debris off of burner tubes. DO NOT ENLARGE BURNER PORTS (OPENINGS). Wash inside of cooking box with warm soapy water and a water rinse.
- Inside Lid** - While lid is warm, wipe inside with paper towel to prevent grease build-up. Flaking built-up grease resembles paint flakes.
- Stainless steel surfaces** - Wash with a soft cloth and a soap and water solution. Be careful to scrub with the grain direction of the stainless steel.
- Do not use cleaners that contain acid, mineral spirits or xylene. Rinse well after cleaning.**

# LIGHTING THE MAIN BURNERS

Summary lighting instructions are printed on a card located inside of the door.

**EACH SET OF LEFT AND RIGHT BURNERS LIGHT INDEPENDENTLY.**

**Note - Always light the LEFT burner first. Each RIGHT burner ignites from the LEFT burner adjacent to it.**

## Crossover® ignition system

*Note - The Crossover® ignition system ignites the left burner with a spark from the igniter electrode inside the Gas Catcher™ ignition chamber. The spark is generated by battery ignition.*

**⚠WARNING: Check hose before each use of grill for nicks, cracking, abrasions or cuts. If the hose is found to be damaged in any way, do not use the grill. Replace using only Vieluxe® authorized replacement hose. Contact Vieluxe® Customer Service at 1-866-VIELUXE.**

**1** Open the lid.

### ⚠DANGER

**Failure to open the lid while igniting the grill's burners, or not waiting 5 minutes to allow the gas to clear if the grill does not light, may result in an explosive flare-up which can cause serious bodily injury or death.**

**2** Make sure all burner control knobs are turned OFF. (Push control knob down and turn clockwise to ensure that it is in the OFF position.)

*Note - Cover the rotisserie burner with rotisserie burner cover when not in use.*

**3** Turn on the gas supply.

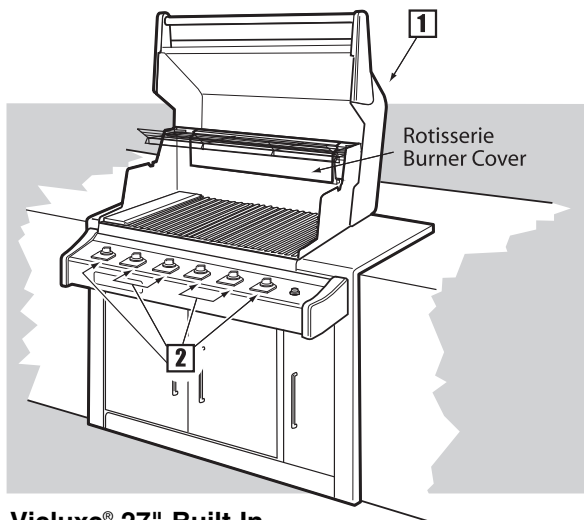

Vieluxe® 27" Built-In

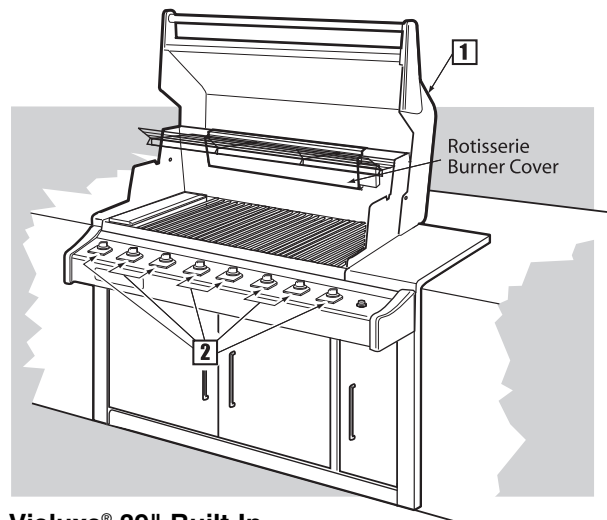

Vieluxe® 39" Built-In

- 4 Select and light each LEFT and RIGHT burner set independently.
- 5 Push LEFT burner control knob down and turn to HI / START in each burner set.

**⚠WARNING: Do not lean over the open grill while lighting.**

- 6 Push and hold down the igniter button until burner ignites. You will hear the igniter sparking.
- 7 Check that the burner is lit by looking down through the cooking grates.

**⚠DANGER: If the burner does not light, turn the LEFT burner control knob to OFF and wait 5 minutes to let the gas clear before you try again or try to light with a match.**

- 8 After the LEFT burner is lit you can turn on the RIGHT burner adjacent to it. The RIGHT burner ignites from the LEFT.

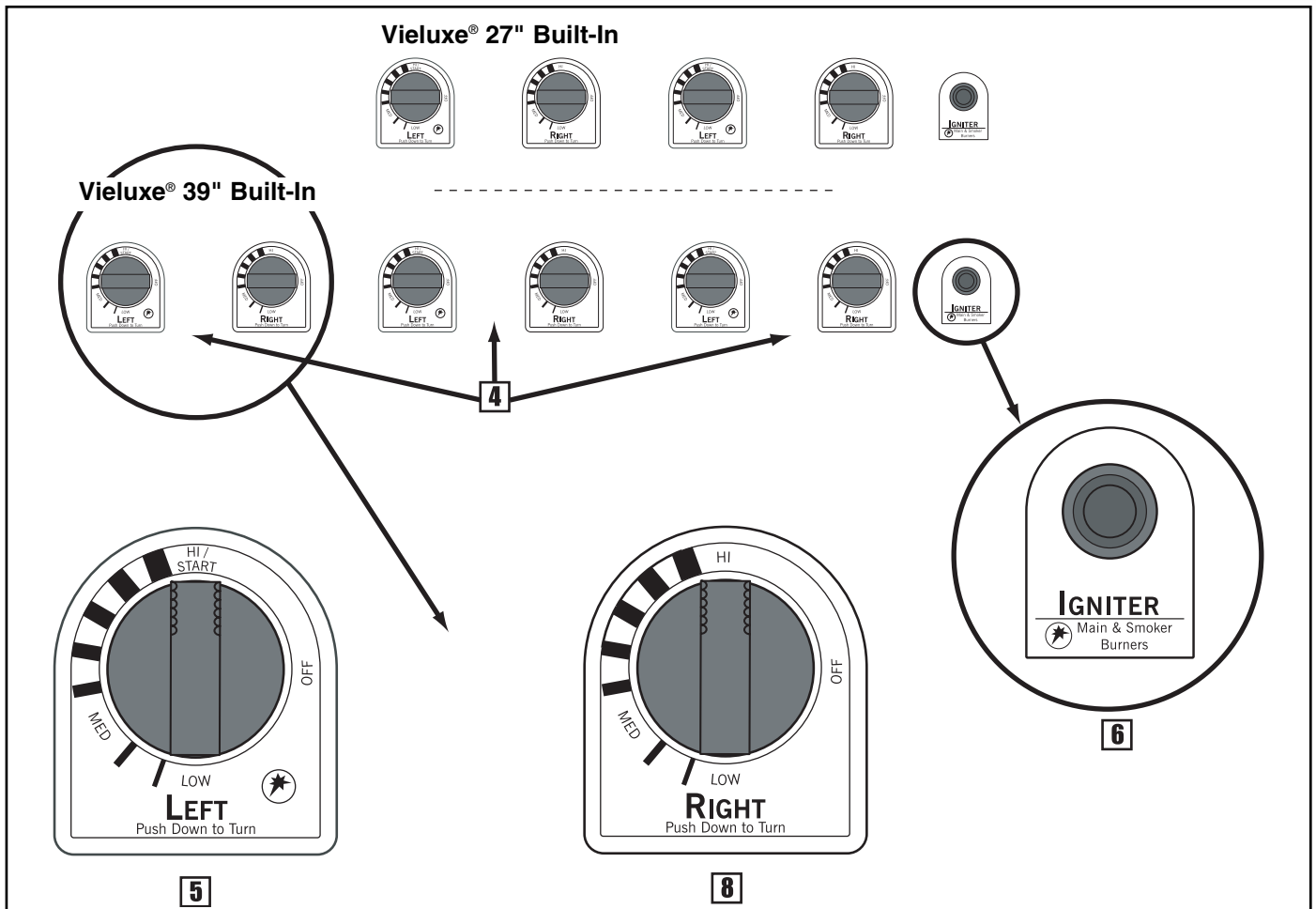

### To extinguish

Push down and turn each burner control knob clockwise to OFF position. Turn gas supply OFF at the source.

# MANUALLY LIGHTING THE MAIN BURNERS

Summary lighting instructions are printed on a card located inside of the door.

**EACH SET OF LEFT AND RIGHT BURNERS LIGHT INDEPENDENTLY.**

*Note: Always light the LEFT burner first. Each RIGHT burner ignites from the LEFT burner adjacent to it.*

**⚠WARNING: Check hose before each use of grill for nicks, cracking, abrasions or cuts. If the hose is found to be damaged in any way, do not use the grill. Replace using only Vieluxe® authorized replacement hose. Contact Vieluxe® Customer Service at 1-866-VIELUXE.**

**1** Open the lid.

## **⚠ DANGER**

**Failure to open lid while igniting the grill, or not waiting 5 minutes to allow the gas to clear if the grill does not light, may result in an explosive flame-up which can cause serious bodily injury or death.**

**2** Make sure all burner control knobs are turned OFF. (Push each burner control knob down and turn clockwise.)

*Note - Cover the rotisserie burner with rotisserie burner cover when not in use.*

**3** Turn on the gas supply valve.

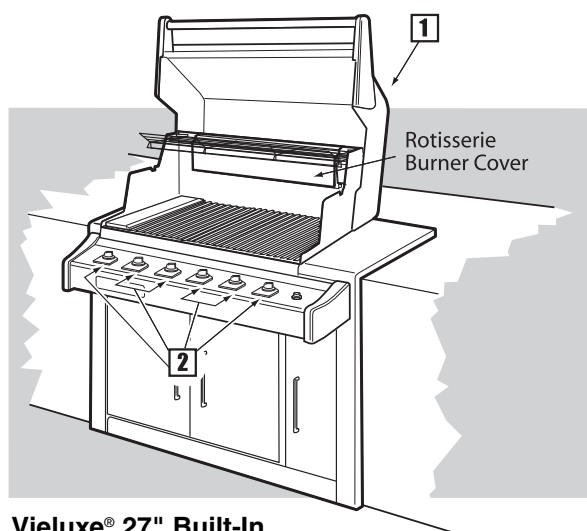

**Vieluxe® 27" Built-In**

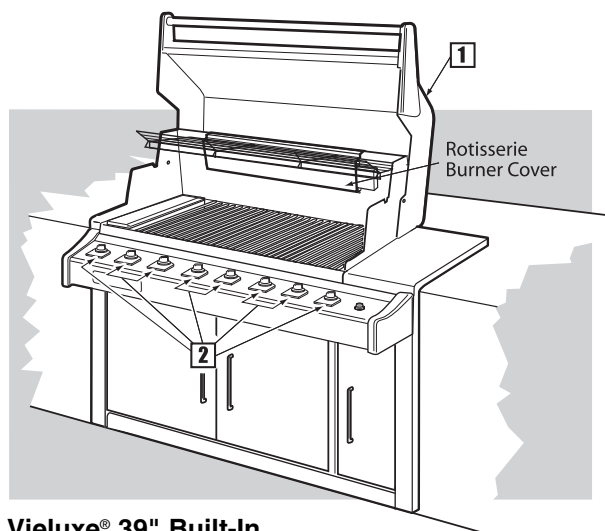

**Vieluxe® 39" Built-In**

- 4** Select and light each LEFT and RIGHT burner set independently.
- 5** Put a match in the match holder and strike the match.
- 6** Insert match holder and lit match down through cooking grates and Flavorizer® bars to ignite LEFT burner in each selected burner set.

**⚠WARNING: Do not lean over open grill while manually lighting.**

- 7** Push LEFT burner control knob down and turn to HI / START in each burner set.

**⚠DANGER: If LEFT burner fails to ignite turn LEFT burner control knob to OFF and wait 5 minutes before attempting to ignite again.**

- 8** After the LEFT burner is lit you can turn on the RIGHT burner adjacent to it. The RIGHT burner ignites from the LEFT.

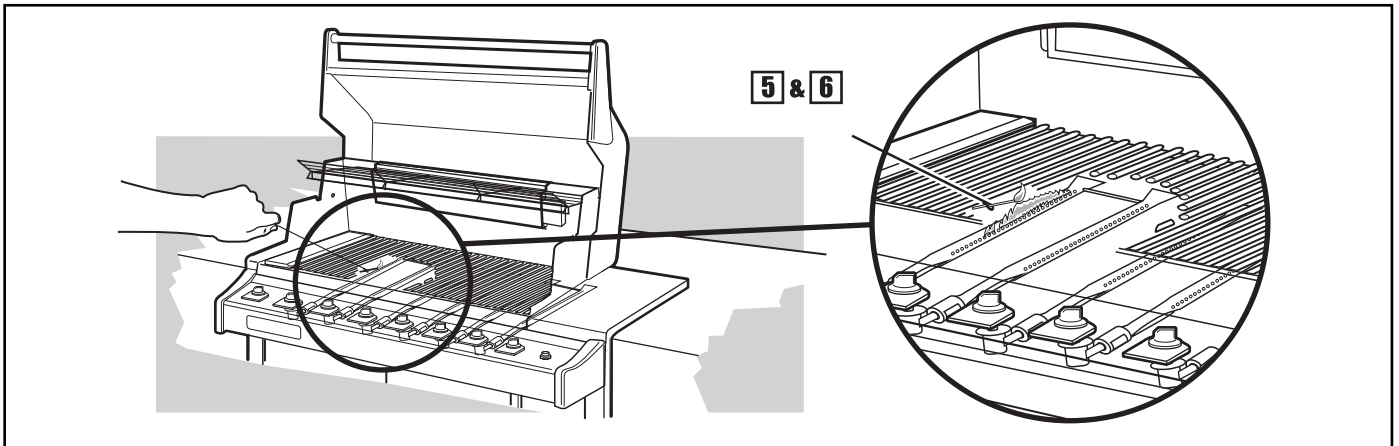

### To extinguish

Push down and turn each burner control knob clockwise to OFF position. Turn gas supply OFF at the source.

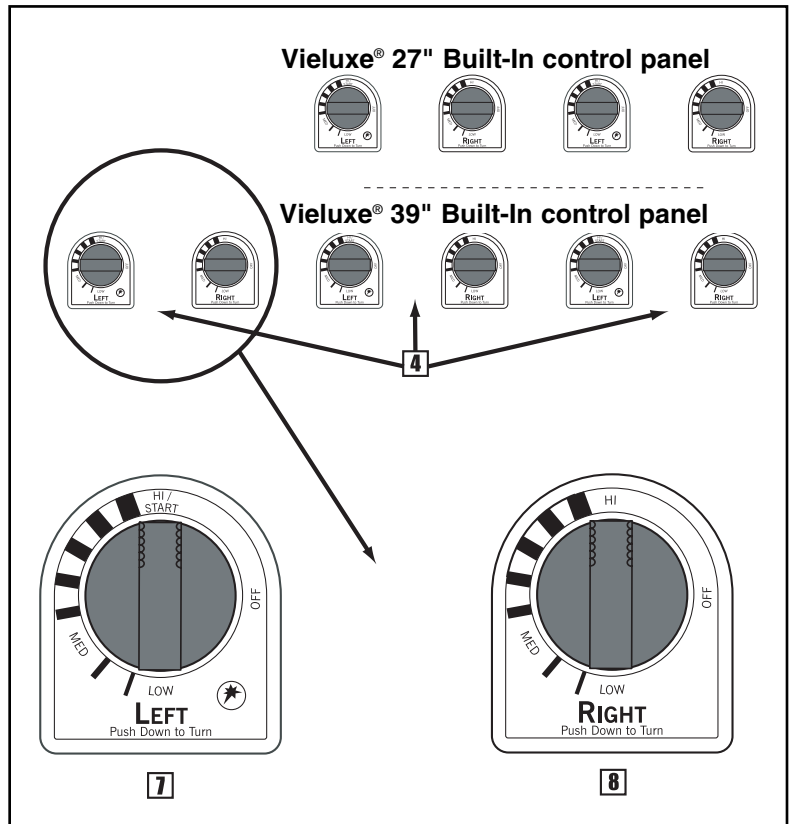

# USING THE VIELUXE® SMOKER

The Vieluxe® smoker uses presoaked wood chips. For best results with faster cooking foods like steaks, burgers and chops, etc., we recommend using finer wood chips because they ignite and create smoke faster. For longer cooking foods such as roasts, chicken and turkeys, etc., we recommend using larger wood chunks because they ignite slowly and provide smoke for a longer period of time. As you gain experience in using your Vieluxe® smoker, we encourage you to experiment with different combinations of wood chips and chunks to find the smoke flavor that best suits your taste.

## To use the Vieluxe® smoker

Before each use, empty the Vieluxe® smoker of ash to allow proper air flow.

As a starting point, soak wood chips in water for at least 30 minutes before using. (Wet wood will produce more smoke flavor.) Place a handful of wood chips or a few larger chunks in the bottom of the smoker body(1). As you gain experience in smoking, increase or decrease the amount of wood to suit your taste.

*Note - Always grill with the lid closed to allow the smoke to fully penetrate the food*

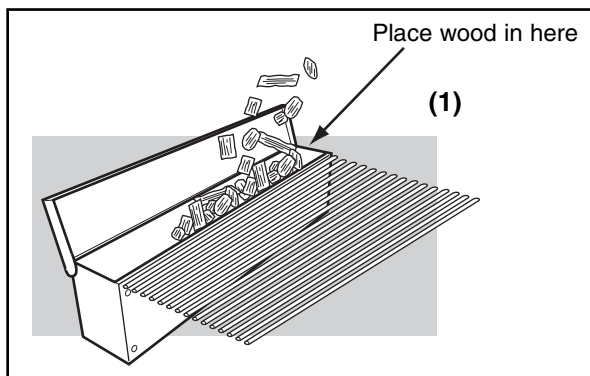

Light the smoker burner by following the instructions for Lighting The Smoker Burner on page 11. (Summary lighting instructions are printed on a card inside of the cabinet door.) After wood starts to smolder turn control knob to low.

Smoke will start in approximately 10 minutes and last as long as 45 minutes. If you require more smoke flavor, refill the smoker with wood chips and /or chunks. Keep the lid of the grill closed while cooking.

*Note - After refilling smoker, smoke will take about 10 to 15 minutes to start again.*

### **⚠ DANGER**

**Do not use any flammable fluid in the Vieluxe® smoker to ignite the wood. This will cause serious bodily injury.**

*Note - Smoking will leave a "smoke" residue on the surface of the smoker. This residue cannot be removed and will not affect the function of the Vieluxe® smoker. To a lesser degree a "smoke" residue will accumulate on the inside of your Vieluxe® gas grill. This residue need not be removed and will not adversely affect the function of your Vieluxe® gas grill.*

# LIGHTING THE SMOKER BURNER

Summary lighting instructions are printed on a card located inside of the door.

**⚠WARNING:** Check hose before each use of grill for nicks, cracking, abrasions or cuts. If the hose is found to be damaged in any way, do not use the grill. Replace using only Vieluxe® authorized replacement hose. Contact Vieluxe® Customer Service at 1-866-VIELUXE.

- 1 Open the grill lid.

## ⚠DANGER

Failure to open the lid while igniting the grill's burners, or not waiting 5 minutes to allow the gas to clear if the grill does not light, may result in an explosive flare-up which can cause serious bodily injury or death.

- 2 Open smoker box lid
- 3 Fill smoker with water soaked wood chunks or chips.
- 4 Make sure all burner control knobs are turned OFF. (Push control knob down and turn clockwise to ensure that it is in the OFF position.)

Note - Cover the rotisserie burner with rotisserie burner cover when not in use.

- 5 Turn on the gas supply.

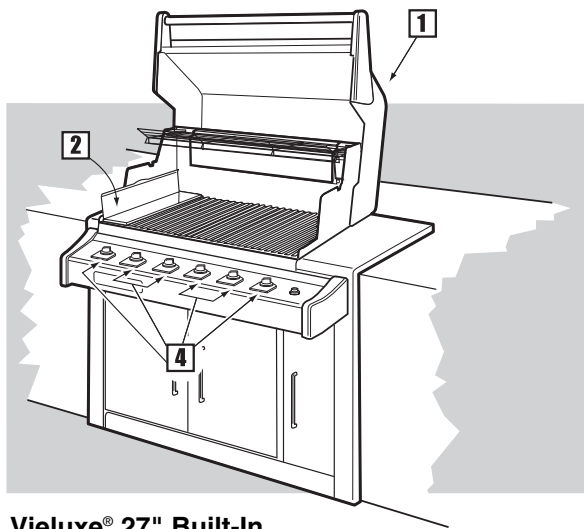

Vieluxe® 27" Built-In

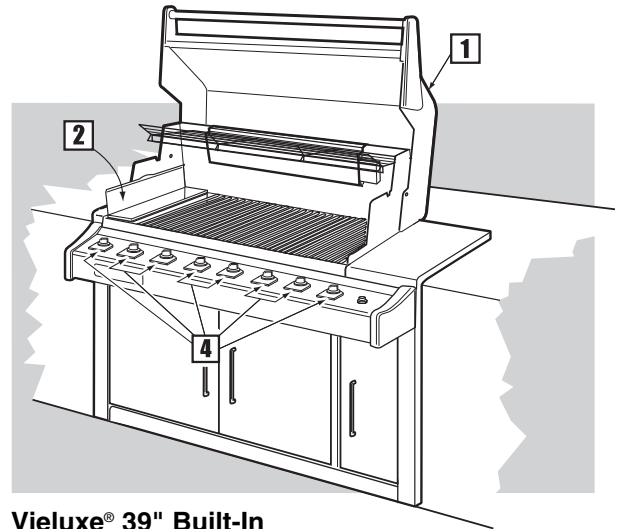

Vieluxe® 39" Built-In

**⚠WARNING:** Do not lean over the open grill while lighting.

- 6 Push smoker burner control knob down and turn to HI / START.
  - 7 Push and hold down the Igniter button until burner ignites. You will hear the igniter sparking.
  - 8 Check that the burner is lit by looking through the cooking grate.
- ⚠DANGER:** If the smoker burner does not light, turn the burner control knob to OFF and wait 5 minutes to let the gas clear before you try again or try to light with a match.
- 9 Close smoker cover after wood starts to smolder and turn control knob to low.

## To extinguish

Push down and turn each burner control knob clockwise to OFF position. Turn gas supply OFF at the source.

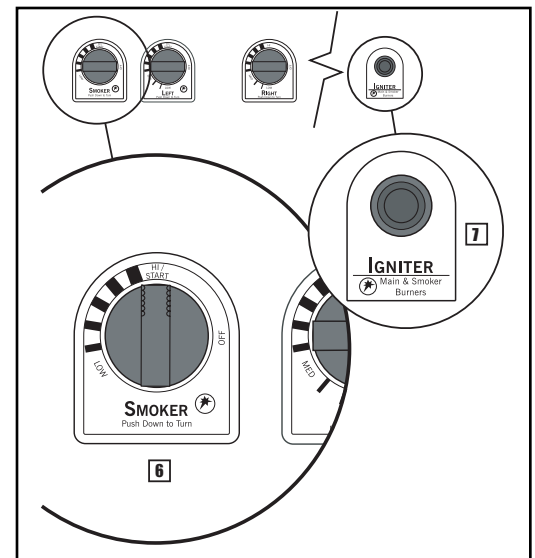

Control panel

# MANUALLY LIGHTING THE SMOKER BURNER

Summary lighting instructions are printed on a card located inside of the door of grill.

**⚠WARNING:** Check hose before each use of grill for nicks, cracking, abrasions or cuts. If the hose is found to be damaged in any way, do not use the grill. Replace using only Vieluxe® authorized replacement hose. Contact Vieluxe® Customer Service at 1-866-VIELUXE.

- 1 Open the lid.

## ⚠DANGER

Failure to open the lid while igniting the burners, or not waiting 5 minutes to allow the gas to clear if the grill does not light, may result in an explosive flare-up which can cause serious bodily injury or death.

- 2 Open smoker box lid.
- 3 Fill smoker with water soaked wood chunks or chips.
- 4 Make sure all burner control knobs are turned OFF. (Push control knob down and turn clockwise to ensure that it is in the OFF position.)

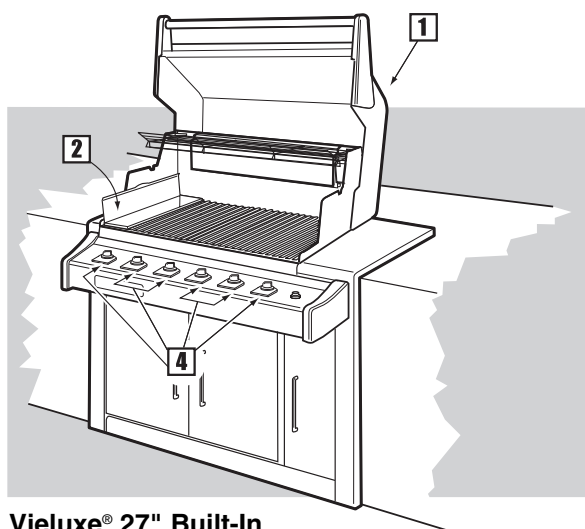

Vieluxe® 27" Built-In

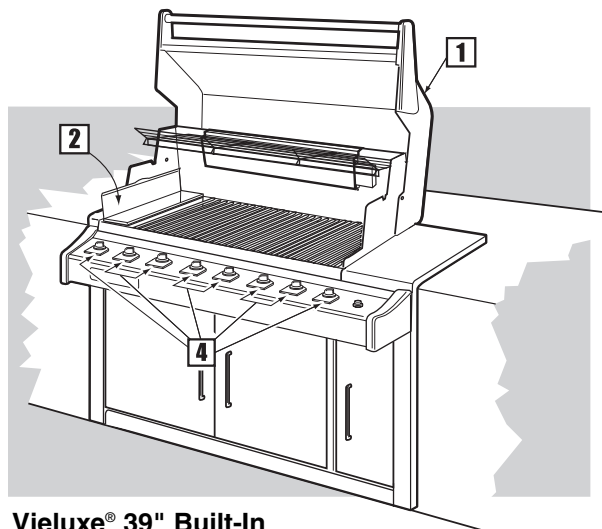

Vieluxe® 39" Built-In

*Note - Cover the rotisserie burner with rotisserie burner cover when not in use.*

- 5** Turn on the gas supply.
- 6** Put a match in the match holder and strike the match.
- 7** Insert match holder and lit match down through cooking grates and Flavorizer® bars to ignite smoker burner.

**⚠WARNING: Do not lean over the open grill while lighting.**

- 8** Push smoker burner control knob down and turn to HI / START.
- 9** Check that the burner is lit by looking down through the cooking grate.

**⚠DANGER: If the smoker burner does not light, turn the burner control knob to OFF and wait 5 minutes to let the gas clear before you try again.**

- 9** Close smoker cover after wood starts to smolder and turn control knob to low.

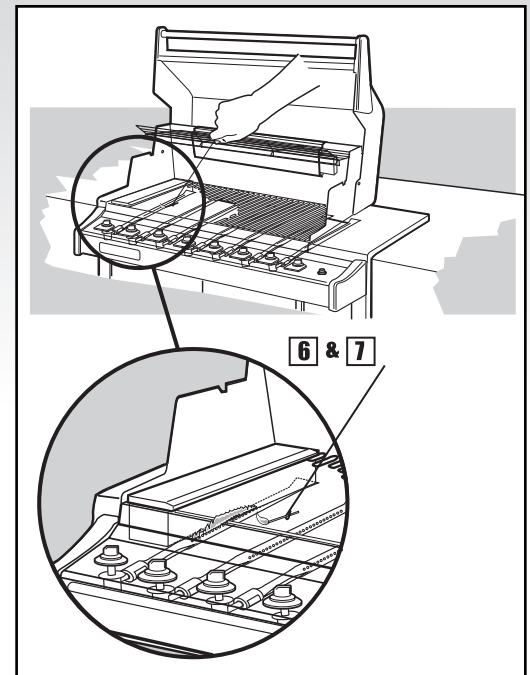

## **To extinguish**

**Push down and turn each burner control knob clockwise to OFF position. Turn gas supply OFF at the source.**

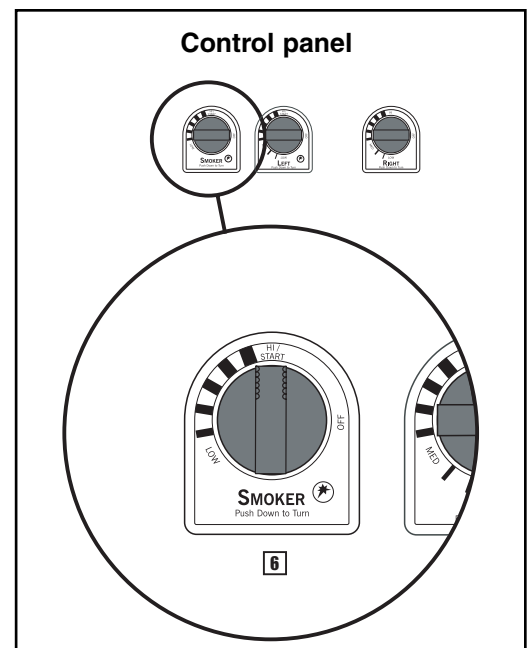

# ROTISSERIE ASSEMBLY

Parts required: rotisserie motor bracket(1), rotisserie motor(1), rotisserie shaft(1) and spitforks(2 or 4)

## 1. Install the motor bracket

Attach the motor bracket onto the left side of the cook box by mounting the bracket key holes over the welded bolts on the cooking box.

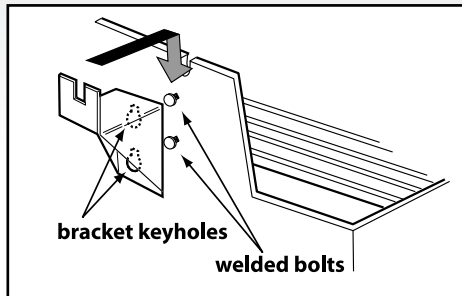

Push the bracket down to lock into position.

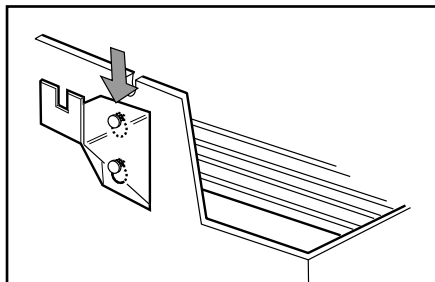

## 2. Attach the motor

Slide the motor onto the motor bracket.

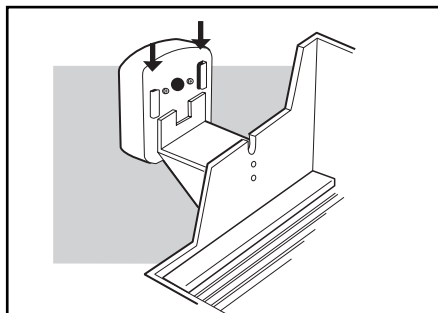

## 3. Put the spit forks on the rotisserie shaft

Slide the spit forks onto the shaft so that the tines are facing each other. Reverse forks to each other so that one fork screw is on top and one is on the bottom, as shown in illustration. Screw in the split fork screws to hold the forks in place.

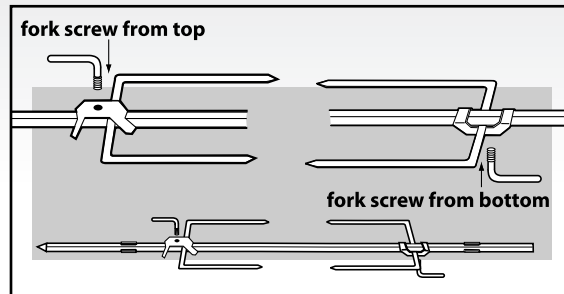

## 4. Insert the rotisserie shaft in the motor

Insert the pointed end of the rotisserie shaft into the motor.

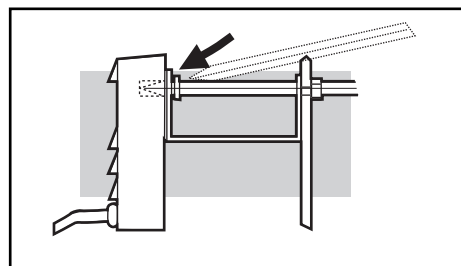

## 5. Set the rotisserie shaft onto rotisserie support block.

Place the handle end of rotisserie onto the support rollers.

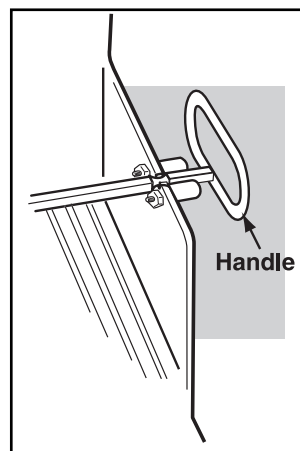

# USING THE VIELUXE® ROTISSERIE

**Note - Before using your Vieluxe® rotisserie, measure your food at the widest point. If it exceeds 9 ½", it is too large to fit the rotisserie. If it is too large, food can be prepared using a roast holder and the Indirect Cooking Method.**

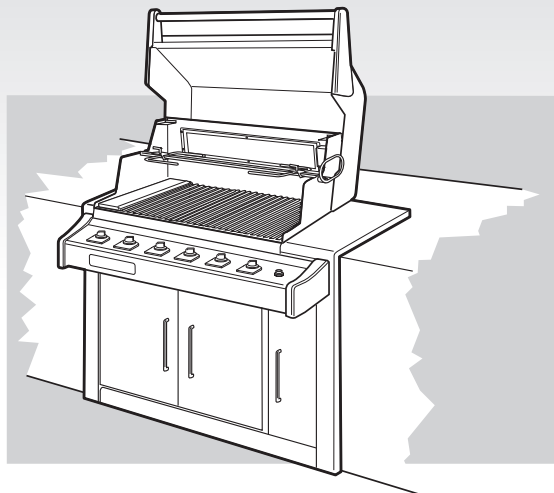

**Vieluxe® 27" Built-In w/ rotisserie**

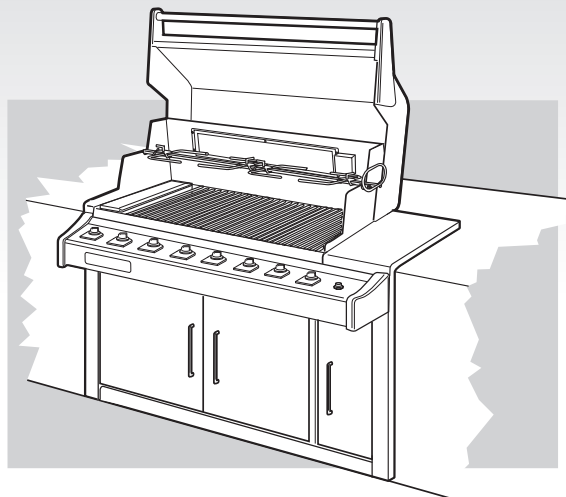

**Vieluxe® 39" Built-In w/ rotisserie**

## Important safeguards

### ⚠ WARNINGS

- Read all instructions before using your rotisserie.
- This rotisserie is for outdoor use only.
- Remove motor and store in a dry place when not in use.
- Do not touch hot surfaces. Use barbecue mitts.
- This rotisserie is not for use by children.
- To protect against electrical hazards do not immerse cord, plugs, or motor in water or other liquids.
- Unplug the motor from outlet when not in use or before cleaning.
- Do not use rotisserie for other than intended use.
- Make sure motor is off before placing it on the motor bracket.
- Do not operate the rotisserie motor with a damaged cord or plug.
- Do not operate the rotisserie motor if it should malfunction.
- The rotisserie motor is equipped with a three prong (grounding) power cord for your protection against shock hazard.
- The power cord should be plugged directly into a properly grounded three prong receptacle. If use of an extension cord is required, be sure that it is a minimum 16 AWG, 3 wire well insulated cord, marked for OUTDOOR USE ONLY and properly grounded.
- When using an extension cord, make sure it is not in contact with a hot or sharp surface.
- Outdoor extension cords should be marked with the letters "W-A" and a tag stating "Suitable for use with outdoor appliances".
- Do not cut or remove the grounding prong from the rotisserie motor power cord.
- Do not let cord hang over any sharp edge or hot surface.
- Use only outdoors, do not expose to rain.
- To reduce the risk of electric shock, keep extension cord connection dry and off the ground.
- A short power cord is supplied to reduce the risk of tripping over the cord. Extension cords may be used, but caution must be taken to prevent tripping over the cord.
- In absence of local codes the rotisserie motor must be grounded electrically in accordance with the National Electrical Code, ANSI / NFPA 70, or Canadian Electrical Code, CSA C22.1.

# USING THE VIELUXE® ROTISSERIE

⚠ **WARNING:** Setup up the rotisserie with food before lighting rotisserie burner.

## Operating

- 1 Remove rotisserie shaft from grill. Remove one spit fork.
- 2 Push the rotisserie shaft through the center of the food.
- 3 Slide the spit fork onto the shaft. Insert the tines of both spit forks into the food. The food should be centered on the shaft. Tighten the spit fork screws

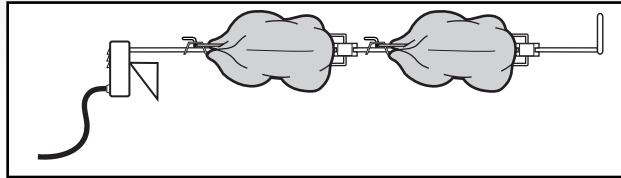

- 4 Place the motor in the bracket, slide to lock (**see page 14, step 2. “Attach the motor”**).
- 5 Insert the pointed end of the rotisserie shaft into the motor. Place the handle end of the rotisserie onto the support rollers (**see page 14, step 4. “Insert the rotisserie shaft in the motor”**).
- 6 The rotisserie shaft should rotate so that the heavy side of the meat or poultry rotates down to the bottom. Large cuts may require the removal of the cooking grates and warming rack to allow full rotation of the shaft. Remount the food if necessary for better balance.
- 7 Turn the motor on.

## Cooking

- Meats should be brought to room temperature before cooking. (30 to 60 minutes should be adequate for most foods. If frozen defrost completely before cooking.)
- Tie meat or poultry with a string, if necessary, to make the shape as uniform as possible before putting it on the spit.
- It may be necessary to remove the cooking grates and warming rack to allow large cuts to turn freely.
- Follow lighting instructions for rotisserie burner on next page.
- Set rotisserie burner on Med-High based on outside air temperatures.
- Place food within area of burner.
- If you wish to save drippings for gravy, place a drip pan directly under the food on top of the Flavorizer® bars.

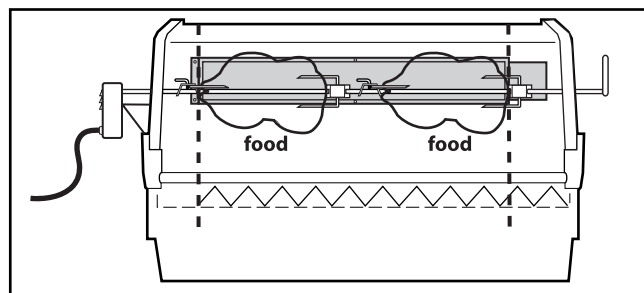

- Food preparation steps are the same for rotisserie cooking as for regular cooking. Indicated timing in the cookbook will be the same.
- All cooking is done with the lid closed.
- If foods are too heavy or are irregular shapes, they may not rotate well and should be cooked by the Indirect Method without using the rotisserie.
- Smoker can be used in conjunction with rotisserie for more smoke flavor. (See Using the Vieluxe® smoker on page 11.)

*Note - When using the rotisserie burner, grill thermometer will not reflect the temperature inside the cooking box.*

*Note - When using the rotisserie with the lid closed, only light two of the main burners that are directly under the food being cooked. Use only the low setting.*

# LIGHTING THE ROTISSERIE BURNER

Summary lighting instructions are printed on a card located inside of the door of grill.

**⚠WARNING: Check hose before each use of grill for nicks, cracking, abrasions or cuts. If the hose is found to be damaged in any way, do not use the grill. Replace using only Vieluxe® authorized replacement hose. Contact Vieluxe® Customer Service at 1-866-VIELUXE.**

- 1 Open the lid.
- 2 Remove rotisserie cover by tilting the bottom of the cover towards you as you lift it off of the rotisserie burner.

## ⚠DANGER

**Failure to open the lid while igniting the grill's burners, or not waiting 5 minutes to allow the gas to clear if the grill does not light, may result in an explosive flare-up which can cause serious bodily injury or death.**

- 3 Make sure all burner control knobs are turned OFF. (Push control knob down and turn clockwise to ensure that it is in the OFF position.)
- 4 Turn on the gas supply.

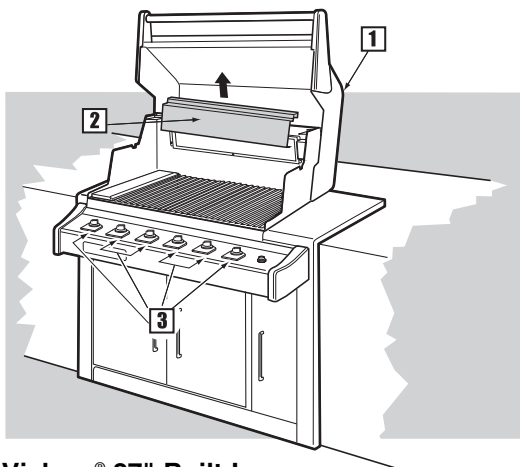

Vieluxe® 27" Built-In

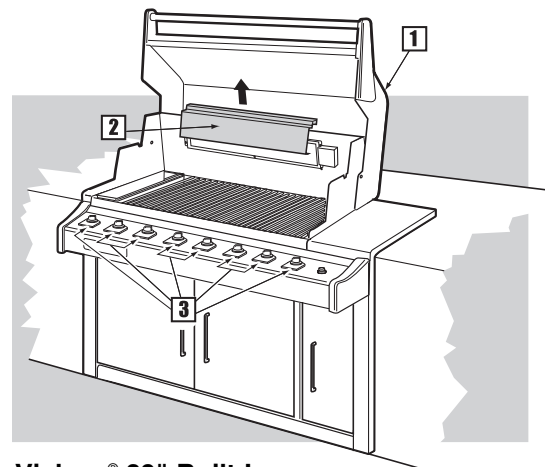

Vieluxe® 39" Built-In

**⚠WARNING: Do not lean over the open grill.**

- 5 Push rotisserie burner control knob down and turn to HI/START. **Continue to hold the control knob down.** Continue to next lighting step.
- 6 Push and hold down the igniter button until burner ignites. You will hear the igniter sparking.
- 7 **Continue to hold the control knob down for ten seconds after the burner has ignited.** Check that the burner is lit by looking for the rotisserie burner to glow red.

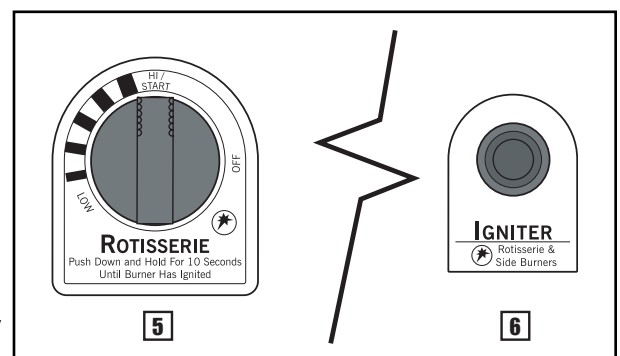

**⚠WARNING: If the rotisserie burner does not light, turn the burner control knob to OFF and wait 5 minutes to let the gas clear before you try again or try to light with a match.**

*Note - When using the rotisserie with the lid closed, only light two of the main burners that are directly under the food being cooked. Use only the low setting.*

## To extinguish

Push down and turn the rotisserie burner control knob clockwise to OFF position. Turn gas supply OFF at the source.

# MANUALLY LIGHTING THE ROTISSERIE BURNER

Summary lighting instructions are printed on a card located inside of the door of grill.

**⚠WARNING:** Check hose before each use of grill for nicks, cracking, abrasions or cuts. If the hose is found to be damaged in any way, do not use the grill. Replace using only **Vieluxe®** authorized replacement hose. Contact **Vieluxe® Customer Service** at 1-866-VIELUXE.

- 1** Open the lid.
- 2** Remove rotisserie cover by tilting the bottom of the cover towards you as you lift it off of the rotisserie burner.

## ⚠DANGER

**Failure to open the lid while igniting the grill's burners, or not waiting 5 minutes to allow the gas to clear if the grill does not light, may result in an explosive flare-up which can cause serious bodily injury or death.**

- 3** Make sure all burner control knobs are turned OFF. (Push control knob down and turn clockwise to ensure that it is in the OFF position.)
- 4** Turn on the gas supply.

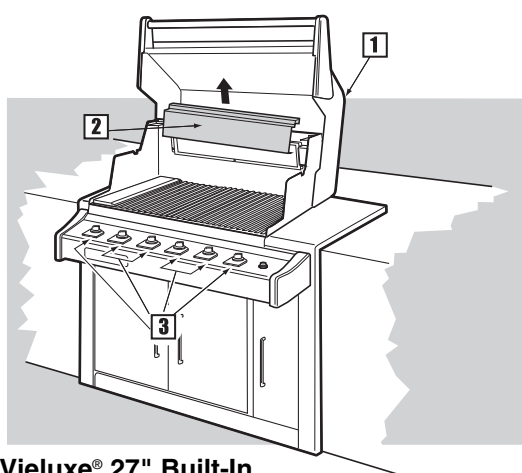

Vieluxe® 27" Built-In

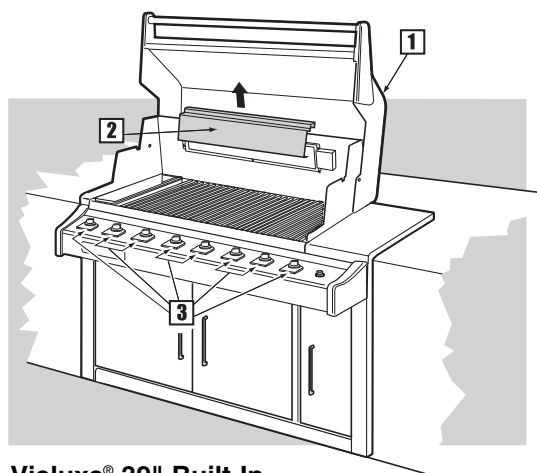

Vieluxe® 39" Built-In

- 5** Put a match in the match holder and strike the match.
- 6** Hold match holder and lit match by right side of rotisserie burner.

**⚠WARNING:** Do not lean over the open grill.

- 7** Push rotisserie burner control knob down and turn to HI/START. **Continue to hold the control knob down.**
- 8** **Continue to hold the control knob down for ten seconds after the burner has ignited.** Check that the burner is lit by looking for the rotisserie burner to glow red.

**⚠WARNING:** If the rotisserie burner does not light, turn the burner control knob to OFF and wait 5 minutes to let the gas clear before you try again.

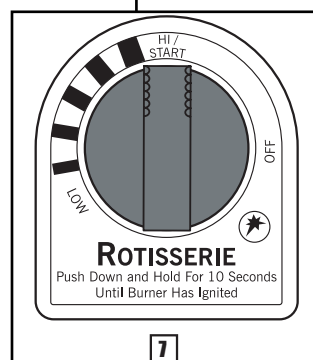
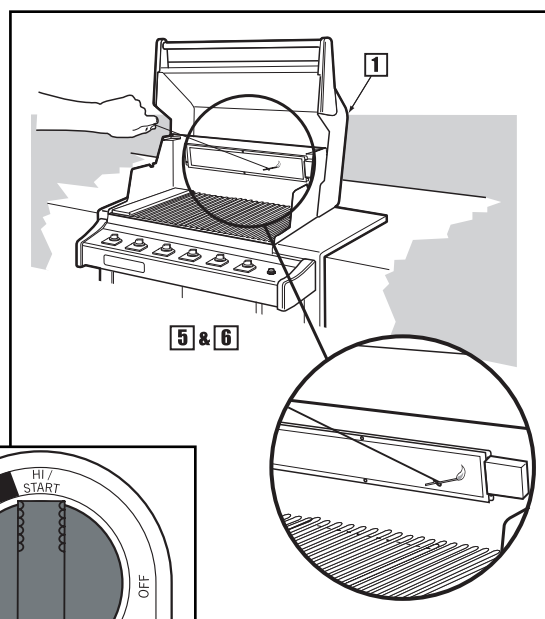

## To extinguish

Push down and turn the rotisserie burner control knob clockwise to OFF position. Turn gas supply OFF at the source.

# GENERAL MAINTENANCE

## Check for gas leaks

### ⚠ WARNING

The gas connections of your Vieluxe® gas grill have been factory tested. We do however recommend that you leak check all gas connections before operating your Vieluxe® gas grill.

## Remove control panel

Part required: Screwdriver

Remove the burner control knobs (1). Remove the wires from the bottom of the igniters (2). The screws (3) need to be removed from the control panel (4) before the control panel is removed from the grill.

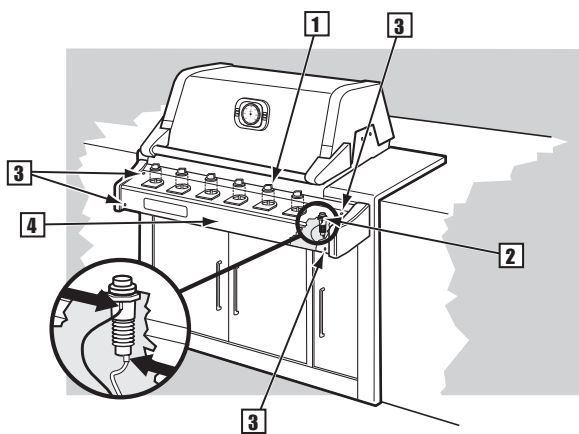

Vieluxe® 27" Built-In

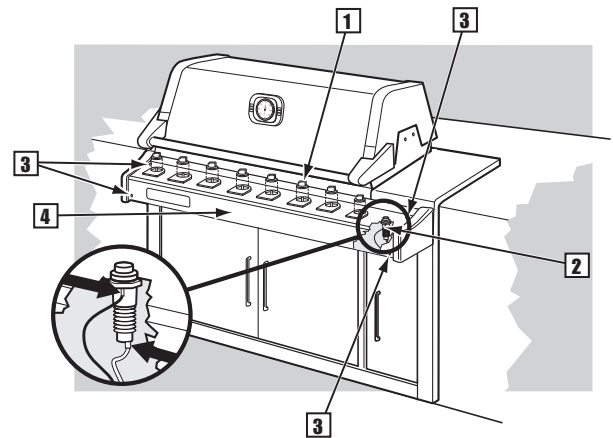

Vieluxe® 39" Built-In

Put your fingers under the front edge of the control panel and lift off.

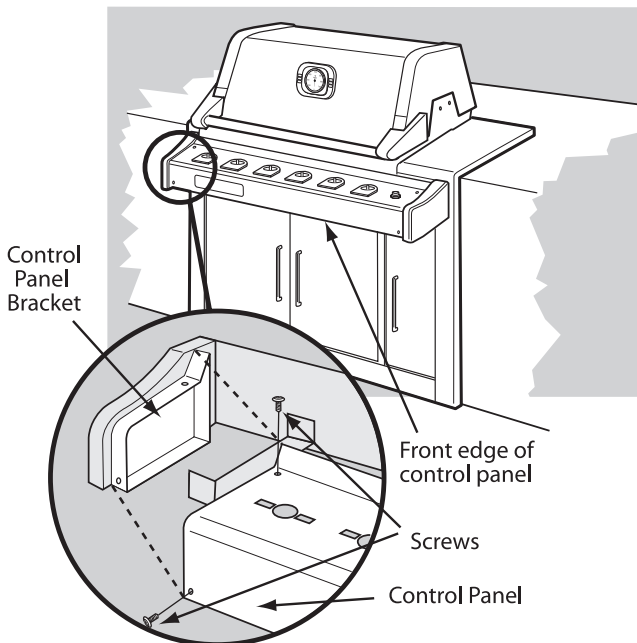

Vieluxe® 27" Built-In

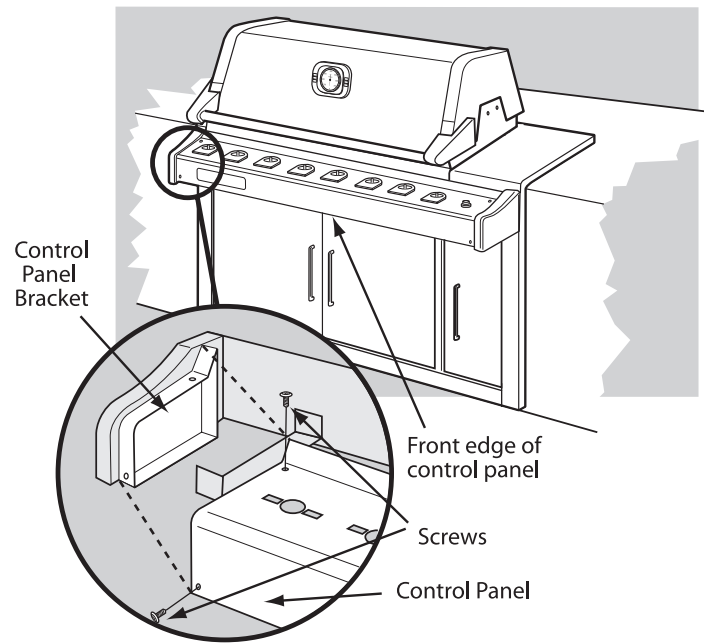

Vieluxe® 39" Built-In

# GENERAL MAINTENANCE

Completely remove the control panel from the cooking box assembly exposing the valves, burners, igniters, and manifold.

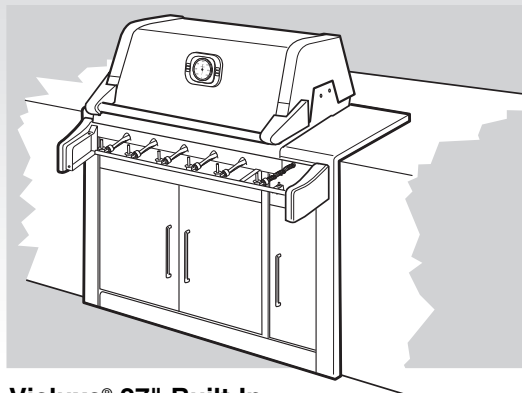

Vieluxe® 27" Built-In

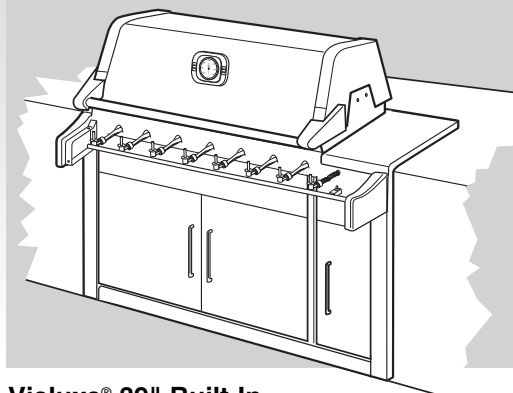

Vieluxe® 39" Built-In

## ⚠ DANGER

**Do not use an open flame to check for gas leaks. Be sure there are no sparks or open flames in the area while you check for leaks. This will result in a fire or explosion which can cause serious bodily injury or death and damage to property.**

**⚠WARNING:** You should check for gas leaks every time you disconnect and reconnect a gas fitting.

Parts required: a soap and water solution and a rag or brush to apply it.

*Note: Since some leak test solutions, including soap and water, may be slightly corrosive, all connections should be rinsed with water after checking for leaks.*

**⚠WARNING:** Make sure all burner control knobs are in the OFF position, including the side burner, smoker, and rotisserie.

1) Turn on the gas supply.

Check for leaks by wetting the connections with the soap and water solution and watching for bubbles. If bubbles form or if a bubble grows there is a leak.

**⚠WARNING:** Do not ignite burners while checking for leaks.

Check:

- a) Valves on left side (valve to manifold connections).
- b) Valves on right side (valve to manifold connections).
- c) Gas lines to manifold connections.

**⚠WARNING:** If there is a leak at valve to manifold connections (a), (b), or gas line to manifold connection (c), turn OFF the gas and retighten the fitting with a wrench and recheck for leaks with a soap and water solution.

If a leak persists after retightening the fitting, turn OFF the gas. **DO NOT OPERATE THE GRILL.** Contact your dealer.

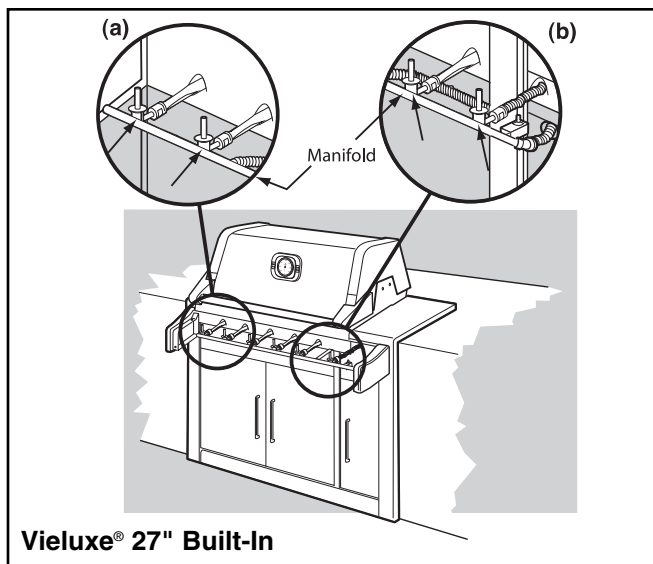

Vieluxe® 27" Built-In

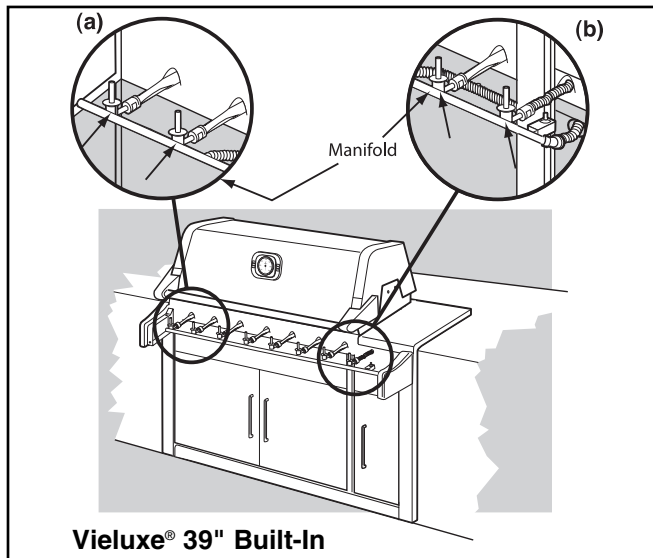

Vieluxe® 39" Built-In

# GENERAL MAINTENANCE

## Reinstall control panel

*Parts required: control panel, screws, and burner control knobs.*

Place the control panel back onto the control panel brackets on either side of the front of the cooking box. Line up screws with screw holes on both the control panel and control panel brackets. Tighten screws.

### Vieluxe® 27" Built-In

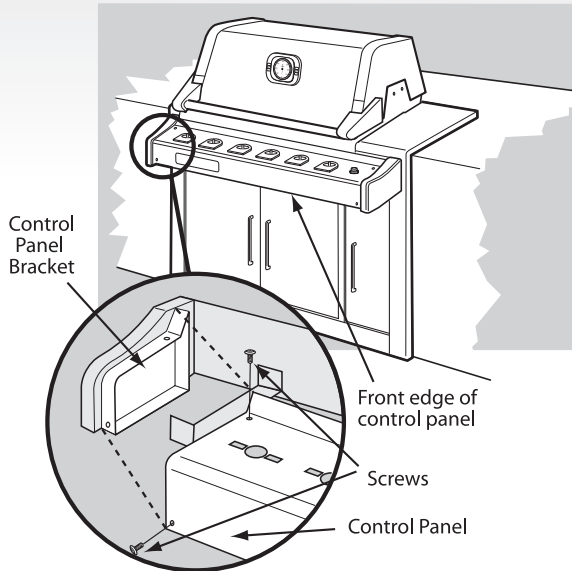

### Vieluxe® 39" Built-In

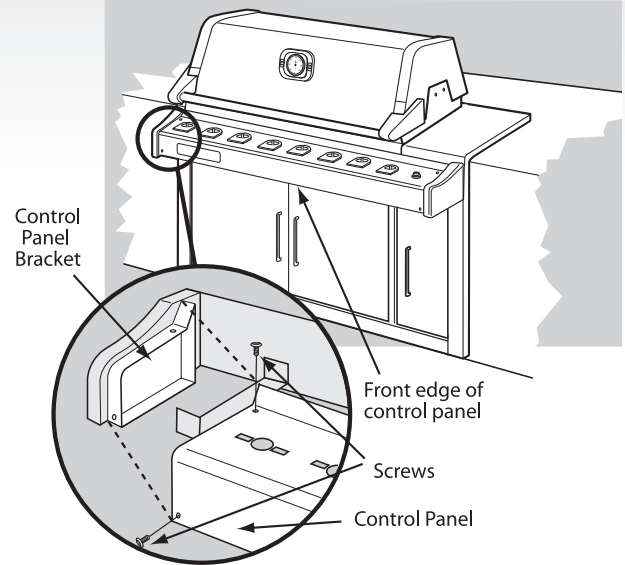

## Reinstall burner control knobs & igniter wires

*You will need: 6 control knobs*

Place corresponding control knobs down through the bezels onto the valve stems. From underside of control panel, replace the two wires of the igniter.

### Vieluxe® 27" Built-In

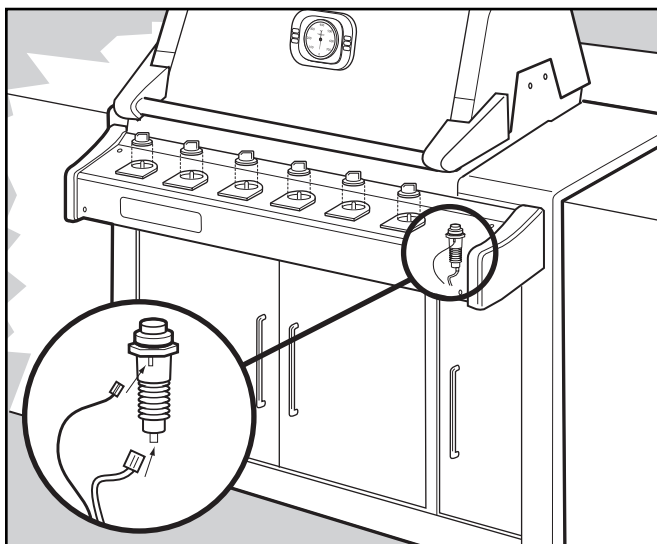

*Parts required: 8 control knobs*

Place corresponding control knobs down through the bezels onto the valve stems. From underside of control panel, replace the two wires of the igniter.

### Vieluxe® 39" Built-In

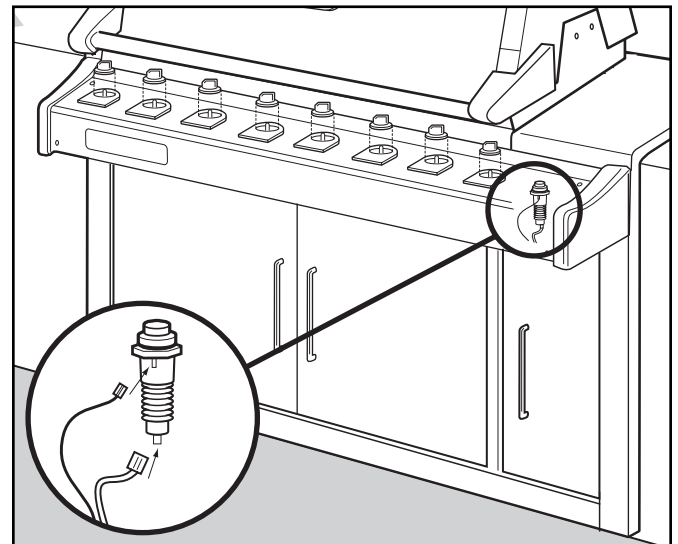

# GENERAL MAINTENANCE

## Spider/Insect screens

Your Vieluxe® gas grill, as well as any outdoor gas appliance, is a target for spiders and other insects. They can nest in the Venturi (1) section of the burner tubes. This blocks the normal gas flow and can cause the gas to flow back out of the air shutter. This could result in a fire in and around the air shutters under the control panel, causing serious damage to your grill.

The burner tube air shutter is fitted with a stainless steel screen (2) to prevent spiders and other insects access to the burner tubes through the air shutter openings.

**We recommend that you inspect the Spider/Insect screens at least once a year. Also inspect and clean the Spider/Insect screens if any of the following symptoms should ever occur:**

1. The smell of gas in conjunction with the burner flames appearing yellow and lazy.
2. Grill does not reach temperature.
3. Grill heats unevenly.
4. One or more of the burners do not ignite.

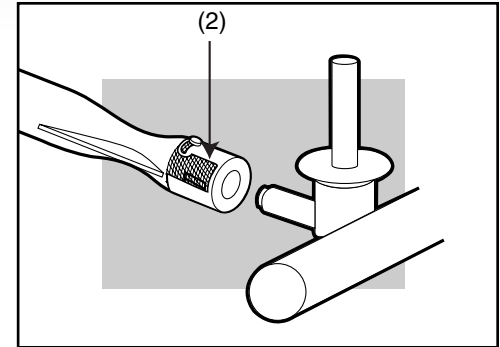
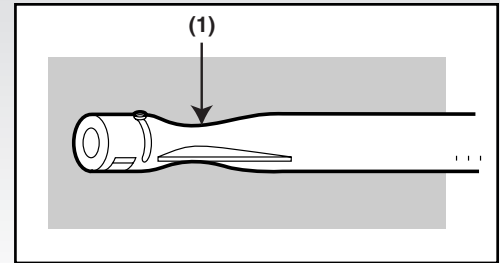

### **⚠ DANGER**

**Failure to correct these symptoms may result in a fire which can cause serious bodily injury or death and cause damage to property.**

## Inspection and cleaning of the Spider/Insect screens

To inspect the Spider/Insect screens, remove the control panel. If there is dust or dirt on the screens, remove the burners for cleaning the screens. Refer to **Maintenance, Replacing Main Burners**. Brush the spider/insect screens, lightly, with a soft bristle brush (i.e. an old toothbrush).

**⚠CAUTION: Do not clean the Spider/Insect screens with hard or sharp tools. Do not dislodge the Spider/Insect screens or enlarge the screen openings.**

Lightly tap the burner to get debris and dirt out of the burner tube. Once the Spider/Insect screens and burners are clean replace the burners.

**If the Spider/Insect screen becomes damaged or cannot be cleaned, call Customer Service toll free at 1-866-VIELUXE<sup>SM</sup> for replacement parts.**

# GENERAL MAINTENANCE

## Main burner flame pattern

The Vieluxe® gas grill burners have been factory set for the correct air and gas mixture. The correct flame pattern is shown at right.

- 1) Burner tube
- 2) Tips occasionally flicker yellow
- 3) Light blue
- 4) Dark blue

If the flames do not appear to be uniform throughout the burner tube, follow the burner cleaning procedures.

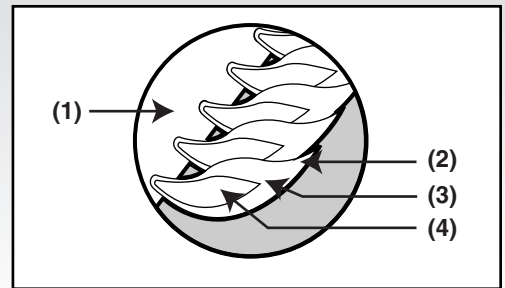

## Main burner cleaning procedure

Turn off the gas supply. Remove the manifold. Look inside each burner with a flashlight.

Clean the inside of the burners with a wire (a straightened-out coat hanger will work). Check and clean the air shutter opening at the ends of the burners. Check and clean the valve orifices at the base of the valves. Use a steel bristle brush to clean outside of burners. This is to make sure all the burner ports are fully open.

**⚠CAUTION: Do not enlarge the burner ports when cleaning.**

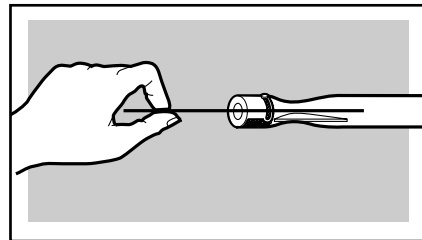
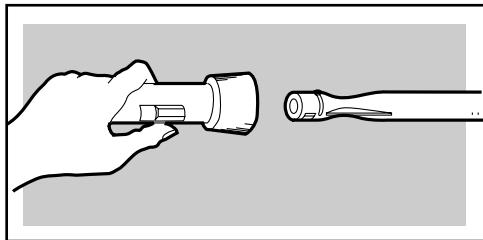

# GENERAL MAINTENANCE

## Replacing main burners

1. Your Vieluxe® gas grill must be OFF and cool.
2. Turn OFF gas at source.
3. Disconnect regulator.
4. Remove cooking grates.
4. Remove Flavorizer® bars.
5. To remove control panel refer to "Remove the control panel" under Check for Gas Leaks on page 19.
6. Remove the manifold: Remove bolts from manifold brackets. Pull manifold out from burner tubes leaving flexible connections on right side in place.

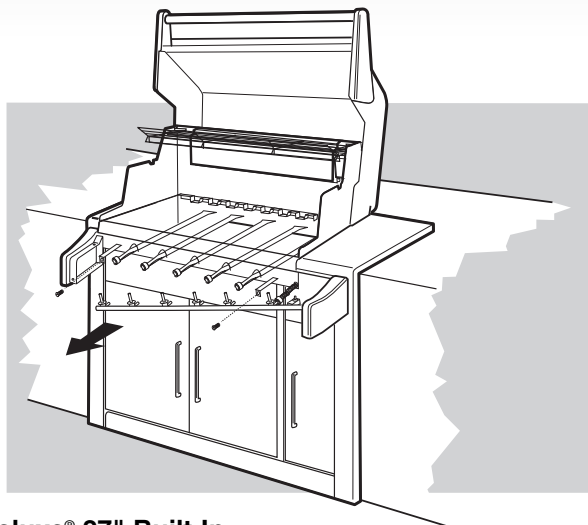

Vieluxe® 27" Built-In

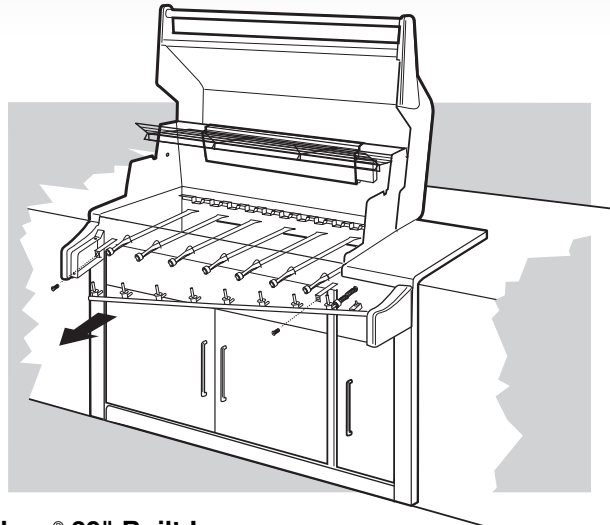

Vieluxe® 39" Built-In

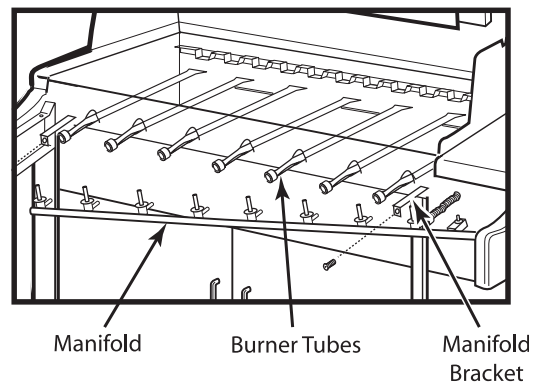
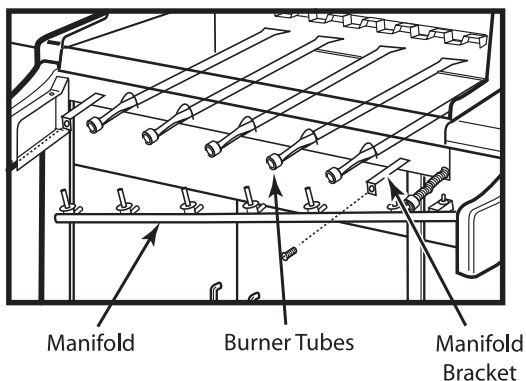

7. Slide the burner assembly from each Burner Set. The left and right burners are connected by the Crossover® tube.

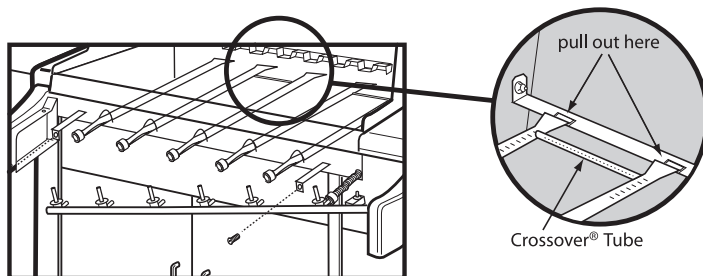

8. Lift and twist the burner assembly slightly to separate the Crossover® tube (1) from the burners. Remove the burner tubes from cooking box.

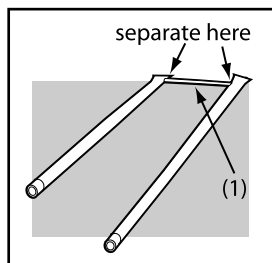

# GENERAL MAINTENANCE

9. To reinstall the burners, reverse steps 3 through 8.

**⚠CAUTION: The burner openings (1) must be positioned properly over the valve orifices (2).**

Check proper assembly before fastening manifold in place.

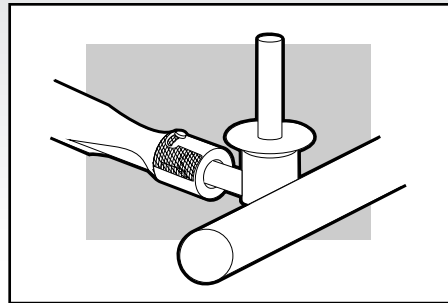
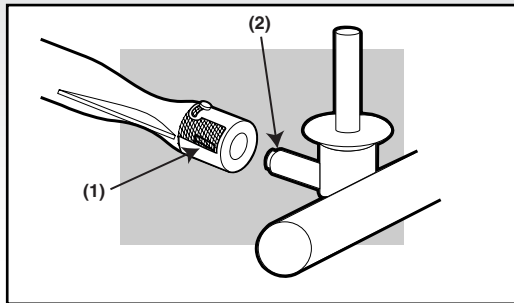

**⚠WARNING: After reinstalling the gas lines, they should be leaked-checked with a soap and water solution before using the grill. (See page 20, “Check for gas leaks.”)**

## Crossover® ignition system operations

If the Crossover® ignition system fails to ignite the left burner in a Heat Zone, light the left burner with a match. If the left burner lights with a match, then check the Crossover® ignition system.

- Check that both ignition wires are attached properly.
- Check that the Crossover® ignition button is activating.
- Replace battery with a like brand battery.
- You should hear the igniter sparking.

If the Crossover® ignition system still fails to light, contact Customer Service toll free at 1-866-VIELUXE<sup>SM</sup>.

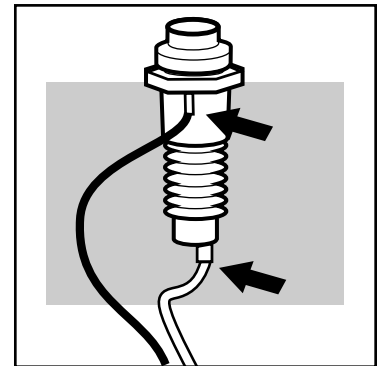

## Replace igniter Batteries

*Parts required: 1 AA alkaline battery per igniter.*

Unscrew igniter button from top of control panel. Remove igniter button and contact spring. Remove old battery and replace with a new AA alkaline battery. Positive end of battery faces up as shown in illustration. Replace contact spring and screw igniter button back down.

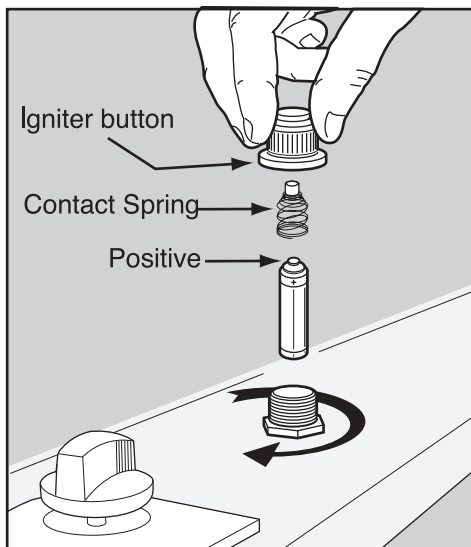

# BURNER SET TROUBLESHOOTING

**⚠WARNING:** Before attempting any troubleshooting steps, all gas controls and supply valves should be in the OFF position.

<b>Problem</b>	<b>Check</b>	<b>Cure</b>
<b>Burners burn with a yellow or orange flame, in conjunction with the smell of gas.</b>	Inspect Spider/Insect screens for possible obstructions. (Blockage of holes.)	Clean Spider/Insect screens. (See Page 22, Section "General Maintenance.")
<b>Burner does not light, or flame is low in HIGH position.</b>	Is gas supply on?	Turn on gas supply.
	Does the left burner light with a match?	If you can light the left burner with a match, then check the Crossover® ignition system.(See p 25)
	Were gas lines purged? (Air removed)	Purge the gas lines. (See installation guide)
<b>Experiencing flare-ups.</b>	Are you preheating grill in the prescribed manner?	All burners on high until grill thermometer reaches 550°F. This is recommended broiling temperature.
	Are the cooking grates and Flavorizer® bars heavily coated with burned-on grease?	Clean thoroughly.
	Is the bottom tray "dirty" and not allowing grease to flow into catch pan?	Clean bottom tray.
<b>⚠CAUTION: Do not line the bottom tray with aluminum foil.</b>		
<b>Burner flame pattern is erratic. Flame is low when burner is on HIGH. Flames do not run the whole length of the burner tube.</b>	Are burners clean?	Clean burners. (See page 23, "General Maintenance".)

**If problems cannot be corrected by using these methods, please contact Customer Service toll free at 1-866-VIELUXE<sup>SM</sup>.**

# ROTISSERIE BURNER TROUBLESHOOTING

**⚠WARNING:** Before attempting any troubleshooting steps, all gas controls and supply valves should be in the OFF position.

<b>Problem</b>	<b>Check</b>	<b>Cure</b>
<b>Burner does not light.</b>	Did you hold the burner control knob down for 10 seconds after burner ignited?	Try to relight burner by holding burner control knob down and continue holding down for 10 seconds after burner has ignited.
	Is the igniter sparking?	Replace battery in igniter button module.
<b>Burner does not light, or flame is low in HIGH position.</b>	Is gas supply on?	Turn on gas supply.
	Were the gas lines purged (air removed)?	Purge the gas lines. (See installation guide).

**If problems cannot be corrected by using these methods, please contact Customer Service toll free at 1-866-VIELUXE<sup>SM</sup>.**



# GRILLING METHODS

You can adjust the LEFT and RIGHT burners as desired. The control settings High (H), Medium (M), Low (L), or Off (O) are described in your cookbook. The cookbook uses these notations to describe the settings of the LEFT and RIGHT burners.

*Note: Cooking conditions may require the adjustment of the burner controls.*

**If burners go out during cooking, turn off all burners and wait 5 minutes before relighting.**

**⚠WARNING: Check the bottom tray and catch pan for grease build-up before each use. Remove excess grease to avoid a grease fire in the bottom tray.**

## **Preheating**

---

Preheating the grill before grilling is important. Light your Vieluxe® gas grill according to the instructions in this Owner's Manual or the Summary lighting instructions located inside of the right hand access door. **Turn both burners in each Heat Zone to High (H), close the lid, and preheat grill with the lid down until grill thermometer reaches 550°F. This is the recommended broiling temperature.**

## **Covered cooking**

---

All grilling is done with the lid down to provide uniform, evenly circulated heat. With the lid closed, the Vieluxe® gas grill cooks much like a convection oven. The thermometer in the lid indicates the cooking temperature inside the grill. All preheating and grilling is done with the lid down. No peeking — heat is lost every time you lift the lid.

# GRILLING METHODS

The most important thing to know about grilling is which cooking method to use for a specific food, Direct or Indirect. The difference is simple: place the food directly over the fire, or arrange the fire on either side of it. Using the right method is the shortest route to great results—and the best way to ensure doneness safety.

## Direct cooking

The Direct Method, similar to broiling, means the food is cooked directly over the heat source. For even cooking, food should be turned once halfway through the grilling time.

Use the Direct method for *foods that take less than 25 minutes to cook*: steaks, chops, kabobs, sausages, vegetables, and more. Direct cooking is also necessary to sear meats. Searing creates that wonderful crisp, caramelized texture where the food hits the grate. It also adds great color and flavor to the entire surface. Steaks, chops, chicken breasts, and larger cuts of meat all benefit from searing.

To sear meats, place them over Direct High heat for 2 to 5 minutes per side. Smaller pieces require less searing time. Usually after searing you finish cooking the food at a lower temperature. You can finish cooking fast-cooking foods by the Direct method; use the Indirect method for longer-cooking foods.

To set up your gas grill for Direct cooking, preheat the grill with all burners on High. Place food on the cooking grate, and then adjust all burners to the temperature noted in the recipe. Close the lid of the grill and lift it only to turn food or to test for doneness at the end of the recommended cooking time.

## Indirect cooking

The Indirect Method is similar to roasting, but with the added benefits of that grilled texture, flavor, and appearance you can't get from an oven. To set up for Indirect cooking, gas burners are lit on either side of the food but not directly beneath it. Heat rises, reflects off the lid and inside surfaces of the grill, and circulates to slowly cook the food evenly on all sides, much like a convection oven, so there's no need to turn the food.

Use the Indirect method for *foods that require 25 minutes or more of grilling time or that are so delicate that direct exposure to the flame would dry them out or scorch them*. Examples include roasts, ribs, whole chickens, turkeys, and other large cuts of meat, as well as delicate fish fillets.

To set up your gas grill for Indirect cooking, preheat the grill with all burners on High. Then adjust the burners on each side of the food to the temperature noted in the recipe and turn off the burner(s) directly below the food. For best results, place roasts, poultry, or large cuts of meat on a roasting rack set inside a disposable heavy-gauge foil pan. For longer cooking times, add water to the foil pan to keep drippings from burning. The drippings can be used to make gravies or sauces.

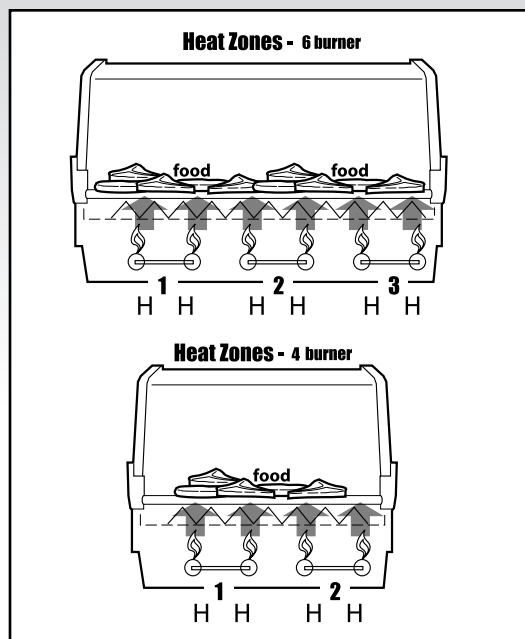

## DIRECT METHOD

Food is placed on the area of the cooking grates directly over the lit burners.

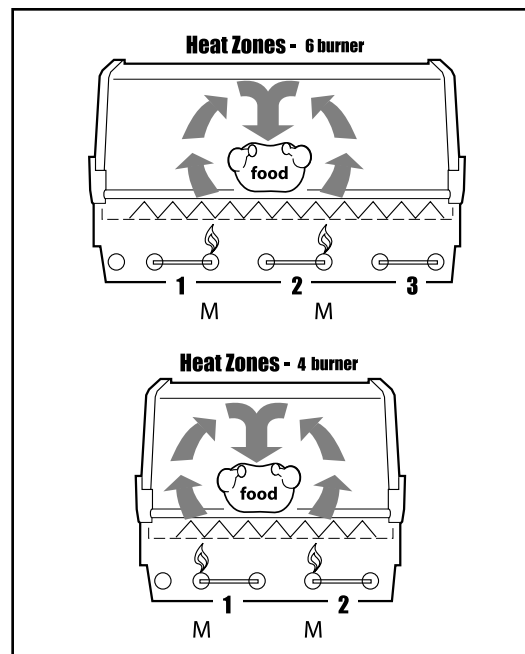

## INDIRECT METHOD

Food is placed on the area of the cooking grates between the lit burners.

## GRILLING TIPS & HELPFUL HINTS

- Always preheat the grill before cooking. Set all burners on HIGH heat and close lid; heat for 10 minutes, or until thermometer registers 500° - 550°F (260° - 288°C).
- Sear meats and cook with the lid down for perfectly grilled food every time.
- Grilling times in recipes are based on 70°F (20°C) weather and little or no wind. Allow more cooking time on cold or windy days, or at higher altitudes. Allow less cooking time in extremely hot weather.
- Grilling times in charts and recipes are approximate. Times can vary because of the weather, or the amount, size and shape of the food being grilled.
- The temperature of your Vieluxe® gas grill may run hotter than normal for the first few uses.
- Grilling conditions may require the adjustment of the burner controls to attain the correct cooking temperatures.
- In general, large pieces of meat will require more cooking time per pound than small pieces of meat. Foods on a crowded cooking grate will require more cooking time than just a few foods. Foods grilled in containers, such as baked beans, will require more time if grilled in a deep casserole rather than a shallow baking pan.
- Trim excess fat from steaks, chops and roasts, leaving no more than a scant ¼ inch of fat. Less fat makes cleanup easier, and is a virtual guarantee against unwanted flare-ups.
- Foods placed on cooking grate directly above burners may require turning or moving to a less hot area.
- Use tongs rather than a fork for turning and handling meats to avoid losing natural juices. Use two spatulas for handling large whole fish.
- If an unwanted flare-up should occur, turn all burners to OFF and move food to another area of the cooking grate. Any flames will quickly subside. After flames subside, relight the grill. NEVER USE WATER TO EXTINGUISH FLAMES ON A GAS GRILL.
- Some foods, such as a casserole or thin fish fillets, will require a container for grilling. Disposable foil pans are very convenient, but any metal pan with ovenproof handles can also be used.
- Always be sure the bottom tray and grease catch pan are clean and free from debris.
- Do not line the funnel-shaped bottom tray with foil. This could prevent the grease from flowing into the grease catch pan.
- Using a timer will help to alert you when “well-done” is about to become “over-done.”

## FOOD HANDLING SAFETY

- Wash hands thoroughly with hot, soapy water before starting any meal preparation and after handling fresh meat, fish and poultry.
- Never place cooked food on the same platter that the raw food was placed on.
- Keep hot foods hot and cold foods cold.
- Do not leave cold foods out of refrigeration for more than two hours.
- Do not defrost meat at room temperature or on a countertop.

# STORAGE

- The gas must be turned off at the gas supply when the Vieluxe® gas grill is not in use.
- When the gas supply is not disconnected from the Vieluxe® gas grill, the appliance must be kept outdoors in a well-ventilated space.
- The Vieluxe® gas grill should be checked for gas leaks and any obstructions in the burner tubes before using. (See Sections: “General Maintenance”)
- Check that the areas under the control panel and the slide out bottom tray are free from debris that might obstruct the flow of combustion or ventilation air.
- The Spider/Insect screens should also be checked for any obstructions. (See page 22, “General Maintenance”)

# CLEANING

**⚠WARNING:** Turn your Vieluxe® gas grill OFF and wait for it to cool before cleaning.

**⚠CAUTION:** Do not clean your Flavorizer® bars or cooking grates in a self-cleaning oven. For availability of replacement cooking grates and Flavorizer® bars contact Customer Service Toll Free at 1-866-VIELUXE<sup>SM</sup>.

**⚠CAUTION:** Do not use oven cleaner, abrasive cleansers (kitchen cleansers) cleaners that contain citrus products, or abrasive cleaning pads on grill, cart surfaces, or control panel.

**Outside surfaces** - Use a warm soapy water solution to clean, then rinse with water.

**Slide out bottom tray** - Remove excess grease, then wash with warm soapy water, then rinse

**Flavorizer® bars and cooking grates** - Clean with a suitable steel bristle brush. As needed, remove from grill and wash with warm soapy water, then rinse with water.

**Catch pan** - You can line the catch pan with aluminum foil. To clean the catch pan, wash with warm soapy water, then rinse.

**Thermometer** - Wipe with warm soapy water; clean with plastic scrub ball.

**Inside cooking module** - Brush any debris off of burner tubes. DO NOT ENLARGE BURNER PORTS (OPENINGS). Wash inside of cooking box with warm soapy water and a water rinse.

**Inside lid** - While lid is warm, wipe inside with paper towel to prevent grease build-up. Flaking built-up grease resembles paint flakes.

**Stainless steel surfaces** - Wash with a soft cloth and a soap and water solution.

**Plastic surfaces** - Wash with a soft cloth and a soap and water solution.

**Do not use cleaners that contain acid, mineral spirits or xylene. Rinse well after cleaning.**

# GRILLING GUIDE

The following cuts, thicknesses, weights, and grilling times are meant to be guidelines rather than hard and fast rules. Cooking times are affected by such factors as altitude, wind, outside temperature, and desired doneness. Two rules of thumb: Grill steaks, fish fillets, boneless chicken pieces, and vegetables using the Direct Method for the time given on the chart or to the desired doneness, turning once halfway through grilling time. Grill roasts, whole poultry, bone-in poultry pieces, whole fish, and thicker cuts using the Indirect Method for the time given on the chart or until an instant-read thermometer reaches the desired internal temperature. Cooking times for beef and lamb are for the USDA's definition of medium doneness unless otherwise noted. Let roasts, larger cuts of meat, and thick chops and steaks rest for 5 to 10 minutes before carving. The internal temperature of the meat will rise by 5 to 10 degrees during this time.

## BEEF

CUT	THICKNESS AND/OR WEIGHT	APPROXIMATE GRILLING TIME
Steak: New York, porterhouse, rib-eye, T-bone, or tenderloin	¾ inch thick	8 to 10 minutes Direct Medium
	1 inch thick	10 to 12 minutes Direct Medium
	1¼ inches thick	14 to 16 minutes; sear 10 minutes Direct High, grill 4 to 6 minutes Indirect Medium
	1½ inches thick	16 to 18 minutes; sear 10 minutes Direct High, grill 6 to 8 minutes Indirect Medium
	2 inches thick	20 to 24 minutes; sear 10 minutes Direct High, grill 10 to 14 minutes Indirect Medium
Skirt steak	¾ to ½ inch thick	5 to 7 minutes Direct High
Flank steak	1½ to 2 pounds, ¾ inch thick	12 to 15 minutes Direct Medium
Kabob	1 to 1½ inch cubes	10 to 12 minutes Direct Medium
Tenderloin, whole	3½ to 4 pounds	35 to 50 minutes (medium rare); sear 20 minutes Direct Medium, grill 15 to 30 minutes Indirect Medium
Ground beef patty	¾ inch thick	8 to 10 minutes Direct Medium
Rib-eye roast, boneless	5 to 6 pounds	1½ to 2 hours Indirect Medium
Tri-tip roast	2 to 2½ pounds	30 to 40 minutes; sear 10 minutes Direct High, grill 20 to 30 minutes Indirect Medium
Rib roast	12 to 14 pounds	2½ to 2¾ hours Indirect Medium
Veal loin chop	1 inch thick	10 to 12 minutes Direct Medium

## LAMB

CUT	THICKNESS OR WEIGHT	APPROXIMATE GRILLING TIME
Chop: loin, rib, shoulder, or sirloin	¾ to 1¼ inches thick	8 to 12 minutes Direct Medium
Leg of lamb, semi-boneless, rolled	6 to 7 pounds	2½ hours Indirect Medium
Rib crown roast	3 to 4 pounds	1 to 1¼ hours Indirect Medium
Ground lamb patty	¾ inch thick	10 minutes Direct Medium
Rack of lamb	1 to 1½ pounds	25 to 35 minutes Direct Medium

## GAME

TYPE	THICKNESS OR WEIGHT	APPROXIMATE GRILLING TIME
Ground buffalo patty	¾ inch thick	7 to 9 minutes (medium) Direct Medium
Buffalo strip steak	1 inch thick	6 to 7 minutes (medium rare) Direct High
Quail, whole	5 ounces	15 to 20 minutes Indirect Medium
Squab, whole or butterflied	1 pound	35 to 45 minutes Indirect Medium
Duck, whole	4 to 6 pounds	1½ to 2 hours Indirect Medium
Duck breast, boneless	7 to 8 ounces	10 to 15 minutes Direct Low
Goose, whole	10 to 12 pounds	3 hours Indirect Medium
Rack of venison	2½ to 3 pounds	45 minutes (medium rare) Indirect Medium

## PORK

CUT	THICKNESS OR WEIGHT	APPROXIMATE GRILLING TIME
Chop: rib, loin, or shoulder	¾ to 1 inch thick	10 to 15 minutes Direct Medium
	1¼ to 1½ inches thick	14 to 18 minutes; sear 8 minutes Direct High, grill 6 to 10 minutes Indirect Medium
Loin chop, boneless	¾ to 1 inch thick	10 to 12 minutes Direct Medium
Loin roast: blade, sirloin, or center rib	3 to 5 pounds	1¼ to 1½ hours Indirect Medium
Rib crown roast	4 to 6 pounds	1½ to 2 hours Indirect Medium
Ribs: country-style, baby back, or spareribs	3 to 4 pounds	1½ to 2 hours Indirect Medium
Tenderloin, whole	¾ to 1 pound	25 to 30 minutes Indirect Medium
Bratwurst		25 to 30 minutes Indirect Medium

## POULTRY

TYPE	WEIGHT	APPROXIMATE GRILLING TIME
Chicken breast, boneless, skinless	6 ounces	8 to 12 minutes Direct Medium
Chicken thigh, boneless, skinless	4 ounces	8 to 10 minutes Direct Medium
Chicken, half	1¼ to 1½ pounds	1 to 1¼ hours Indirect Medium
Chicken pieces, bone-in breast/wing		30 to 40 minutes Indirect Medium
Chicken pieces, bone-in leg/thigh		40 to 50 minutes Indirect Medium
Chicken, whole	3½ to 5 pounds	1 to 1½ hours Indirect Medium
Cornish game hen	1½ to 2 pounds	30 to 45 minutes Indirect Medium
Turkey, whole, unstuffed	10 to 11 pounds	1¼ to 2½ hours Indirect Medium
	12 to 14 pounds	2¼ to 3 hours Indirect Medium
	15 to 17 pounds	2¾ to 3¾ hours Indirect Medium
	18 to 22 pounds	3½ to 4 hours Indirect Medium
	23 to 24 pounds	4 to 4½ hours Indirect Medium
Turkey drumstick	½ to 1½ pounds	¾ to 1¼ hours Indirect Medium
Turkey breast, bone-in	4 to 5 pounds	1 to 1½ hours Indirect Medium

## FISH & SEAFOOD

TYPE	THICKNESS OR WEIGHT	APPROXIMATE GRILLING TIME*
Fish, fillet or steak	¼ to ½ inch thick	3 to 5 minutes Direct High
	½ to 1 inch thick	5 to 10 minutes Direct High
	1 to 1¼ inches thick	10 to 12 minutes Direct High
Fish, whole	1 pound	15 to 20 minutes Indirect Medium
	2 to 2½ pounds	20 to 30 minutes Indirect Medium
	3 pounds	30 to 45 minutes Indirect Medium
Shrimp		2 to 5 minutes Direct High
Scallop		3 to 6 minutes Direct High
Mussel		5 to 6 minutes Direct High (discard any that do not open)
Clam		8 to 10 minutes Direct High (discard any that do not open)
Oyster		3 to 5 minutes Direct High

\*Note: General rule for grilling fish: 4 to 5 minutes per ½-inch thickness; 8 to 10 minutes per 1-inch thickness.

## FRUIT

TYPE	APPROXIMATE GRILLING TIME**
Apple, whole	35 to 40 minutes Indirect Medium
Apple, ½-inch-thick rounds	4 to 6 minutes Direct Medium
Apricot, halved, pit removed	6 to 8 minutes Direct Medium
Banana, halved lengthwise	6 to 8 minutes Direct Medium
Cantaloupe, wedges	6 to 8 minutes Direct Medium
Nectarine, halved lengthwise, pit removed	8 to 10 minutes Direct Medium
Peach, halved lengthwise, pit removed	8 to 10 minutes Direct Medium
Pear, halved lengthwise	10 to 12 minutes Direct Medium
Pineapple, peeled and cored, ½-inch rings or 1-inch wedges	5 to 10 minutes Direct Medium
Strawberry	4 to 5 minutes Direct Medium

\*\*Note: Grilling times for fruit will depend on ripeness.

## VEGETABLES

TYPE	WEIGHT	APPROXIMATE GRILLING TIME
Artichoke, whole		Steam 20 to 25 minutes; cut in half and grill 8 to 10 minutes Direct Medium
Asparagus		6 to 8 minutes Direct Medium
Beet		1 to 1½ hours Indirect Medium
Bell pepper, whole		10 to 12 minutes Direct Medium
Bell pepper, halved or quartered		6 to 8 minutes Direct Medium
Cabbage, whole		2 to 2½ hours Indirect Medium
Chile		7 to 9 minutes Direct Medium
Corn, husked		10 to 12 minutes Direct Medium
Corn, in husk		25 to 30 minutes Direct Medium
Eggplant, ½-inch slices		8 to 10 minutes Direct Medium
Eggplant, halved		12 to 15 minutes Direct Medium
Fennel, ¼-inch slices		10 to 12 minutes Direct Medium
Garlic, whole		45 to 60 minutes Indirect Medium
Green bean, whole		8 to 10 minutes Direct Medium
Green onion, whole		3 to 4 minutes Direct Medium
Leek		14 to 16 minutes Direct Medium
Mushroom: shiitake or button		8 to 10 minutes Direct Medium
Mushroom: portabello		12 to 15 minutes Direct Medium
Onion, whole (leave paper leaves on—do not peel)		45 to 50 minutes Indirect Medium
Onion, halved		35 to 40 minutes Indirect Medium
Onion, ½-inch slices		8 to 12 minutes Direct Medium
Potato, whole		45 to 60 minutes Indirect Medium
Potato, ½-inch slices		14 to 16 minutes Direct Medium
Potato: new, halved		20 to 25 minutes Direct Medium
Pumpkin	3 pounds	1½ to 2 hours Indirect Medium
Squash: acorn	1 pound	40 to 45 minutes Indirect Medium
Squash: buttercup or butternut	2 pounds	50 to 55 minutes Indirect Medium
Squash: pattypan		10 to 12 minutes Direct Medium
Squash: spaghetti	3 pounds	1¼ to 1½ hours Indirect Medium
Squash: yellow, ½-inch slices		6 to 8 minutes Direct Medium
Squash: yellow, halved		6 to 10 minutes Direct Medium
Sweet potato, whole		50 to 60 minutes Indirect Medium
Sweet potato, ¼-inch slices		8 to 10 minutes Direct Medium
Tomatillo		6 to 8 minutes Direct Medium
Tomato: cherry, whole		2 to 4 minutes Direct Medium
Tomato: garden, ½-inch slices		2 to 4 minutes Direct Medium
Tomato: garden, halved		6 to 8 minutes Direct Medium
Tomato: plum, halved		6 to 8 minutes Direct Medium
Tomato: plum, whole		8 to 10 minutes Direct Medium
Zucchini, ½-inch slices		6 to 8 minutes Direct Medium
Zucchini, halved		6 to 10 minutes Direct Medium