



# BUILT-IN CUTOUT DIMENSIONS

## GENERAL CONSTRUCTION DETAILS

Summit® Built-In unit and all other accessory units should be on site before construction begins.

All dimensions have a tolerance of plus or minus +/- 1/4" inch.

The grill frame rests directly on the Island Structure top finished surface. Make sure this surface is level. Do not support the grill from the bottom.

If the supporting structure is going to have an electrical outlet for a rotisserie, it should be on the left side of the structure.

Refer to Summit® Built-In Tank Drawer Installation Instructions for complete gas line locations.

### 28" GRILL

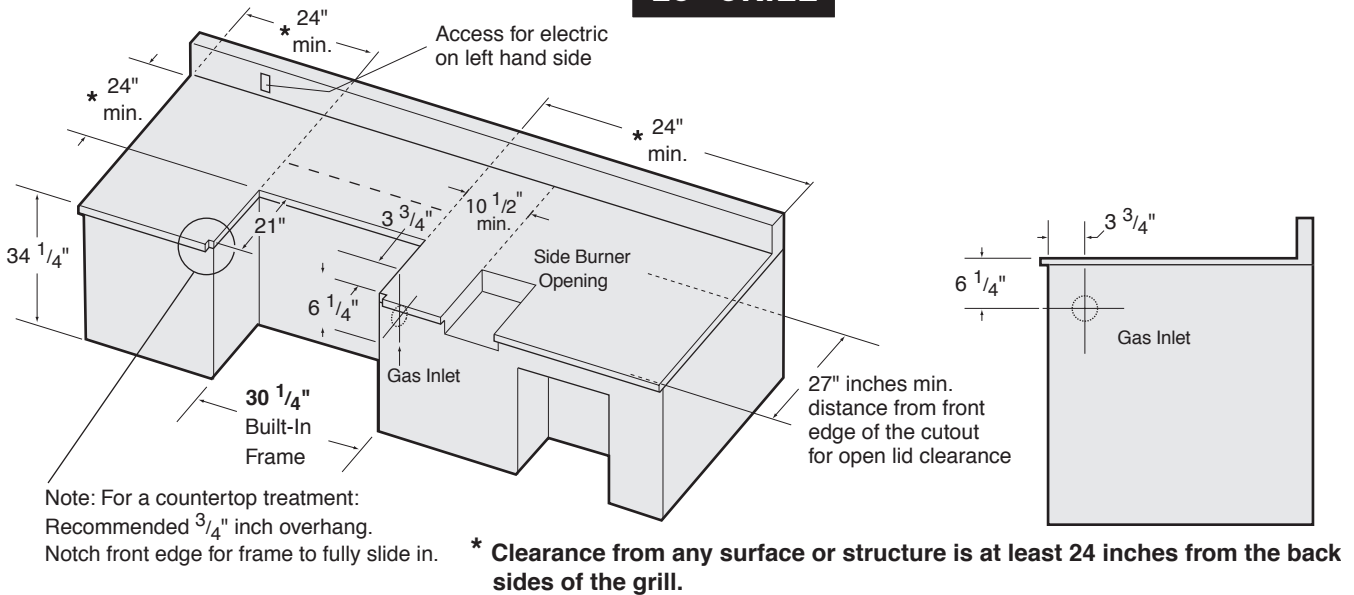

### 36" GRILL

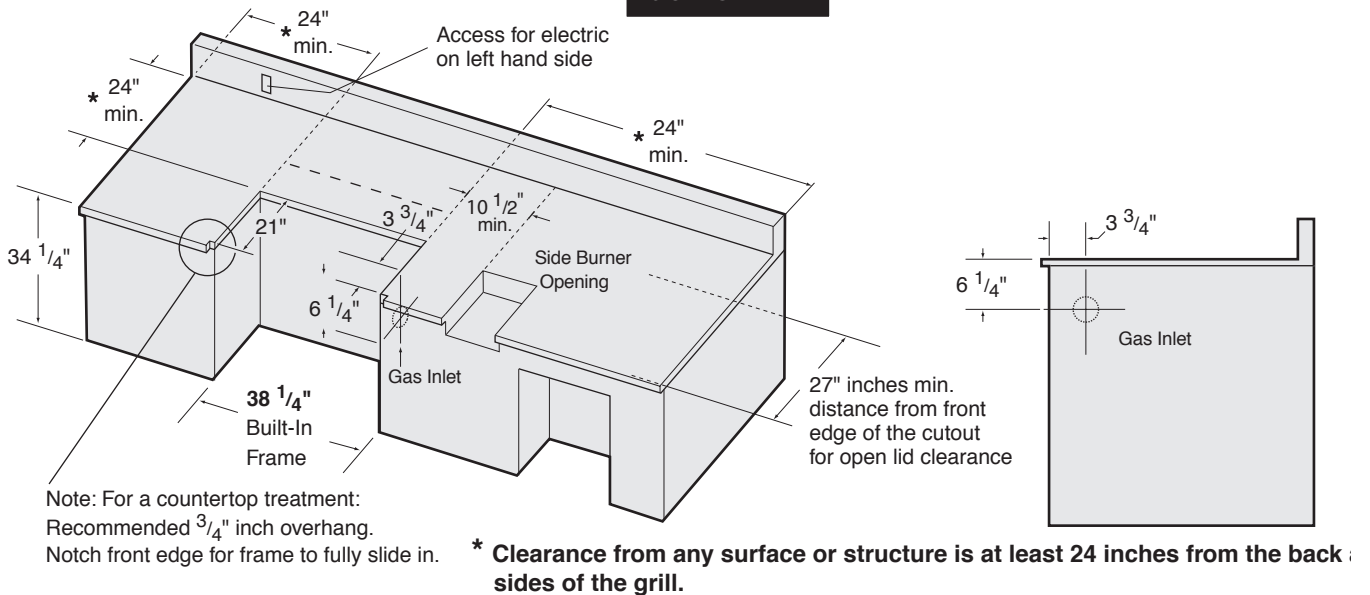

# GAS SUPPLY

## BUILT-IN GAS LINE LOCATIONS

Note: Leave an access in the “island” structure for gas supply and regulator service not inside the grill structure. Weber® has a gas line and regulator access door (part # 36311) available from your dealer or call Customer Service at 1-847-446-1071.

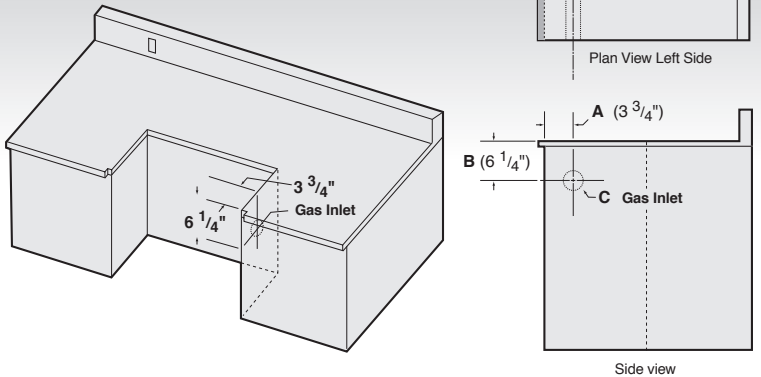

Dimensions	Built-In Gas Line Dimensions		
	28" Grill	36" Grill	Tolerances
<b>A</b>	3 3/4"	3 3/4"	+ 1/8" - 1/8"
<b>B</b>	6 1/4"	6 1/4"	+ 1/8" - 1/8"
<b>C</b>	2 1/2"	2 1/2"	+ 1/8" - 1/8"

Note: Area should be kept clear of sharp, jagged, or extremely abrasive surfaces to avoid possible damage to gas supply lines. Exercise caution when pulling gas lines through built-in structure.

## TYPICAL BULK PROPANE GAS SUPPLY INSTALLATION

We recommend that this installation be done by a LICENSED professional.

### GENERAL SPECIFICATIONS FOR PIPING

Note - Contact your local municipality for building codes regulating outdoor gas grill installations. In absence of Local Codes, you must conform to the latest edition of the National Fuel Gas Code ANSI Z223.1/NFPA 54.

- This grill is designed to operate at 10.5 inches of water column pressure. A LP in line regulator may be necessary for this pressure.

**CAUTION: IF YOUNG CHILDREN ARE IN THE AREA, A LOCKING VALVE SHOULD BE CONSIDERED.**

- Pipe compound should be used which is resistant to the action of liquid propane gas when gas connections are made.
- The gas connections must be firmly attached to rigid, permanent construction.

Note: The information provided in this manual is general for typical installations. We cannot cover all possible installation ideas. We recommend, prior to installation, that you contact your municipality for local building codes and your local fire department for installation verification.

If you have any questions, contact Customer Service at 1-800-446-1071

Table 10-1 Maximum Capacity of Pipe in Cubic Feet of Gas per Hour for Gas Pressures of 0.5 psi or Less and a Pressure Drop of 0.3 Inch Water Column. (Based on a 0.60 Specific Gravity Gas)

Nominal Iron Pipe Size (Inches)	Internal Diameter (Inches)	Length of Pipe (Feet)													
		10	20	30	40	50	60	70	80	90	100	125	150	175	200
1/4	.364	32	22	18	15	14	12	11	11	10	9	8	8	7	6
3/8	.493	72	49	40	34	30	27	25	23	22	21	18	17	15	14
1/2	.622	132	92	73	63	56	50	46	43	40	38	34	31	28	26
3/4	.824	278	190	152	130	115	105	96	90	84	79	72	64	59	55
1	1.049	520	350	285	245	215	195	180	170	160	150	130	120	110	100
1 1/4	1.380	1050	730	590	500	440	400	370	350	320	305	275	250	225	210
1 1/2	1.160	1600	1100	890	760	670	610	560	530	490	460	410	380	350	320
2	2.067	3050	2100	1650	1450	1270	1150	1050	990	930	870	780	710	650	610
2 1/2	2.469	4800	3300	2700	2300	2000	1850	1700	1600	1500	1400	1250	1130	1050	980
3	3.068	8500	5900	4700	4100	3600	3250	3000	2800	2600	2500	2200	2000	1850	1700
4	4.026	17500	12000	9700	8300	7400	6800	6200	5800	5400	5100	4500	4100	3800	3500

©1997 National Fire Protection Association, Inc., and International Approval Services - U.S., Inc. All Rights Reserved.

# GAS SUPPLY

## GAS LINE PIPING

- Refer to the piping chart at the bottom of previous page.
- The corrugated gas line from the manifold is 58 inches long. Do not extend the gas line.
- We have provided the means to make an SAE 45° flare connection. Do not use pipe sealant on this connection.
- If the length of line required does not exceed 50 feet, use a 5/8" O.D. tube. One size larger should be used for lengths greater than 50 feet. Refer to piping chart.
- Gas piping may be copper tubing, type K or L; polyethylene plastic tube, with a minimum wall thickness of .062 inch; or standard weight (schedule 40) steel or wrought iron pipe.
- Copper tubing must be tin-lined if the gas contains more than 0.3 grams of hydrogen sulfide per 100 cubic feet of gas.
- Plastic tubing is suitable only for outdoor, underground use.
- Gas piping in contact with earth, or any other material which may corrode the piping, must be protected against corrosion in an approved manner.
- Underground piping must have a minimum of 18" cover.

## TEST CONNECTIONS

All connections and joints must be thoroughly tested for leaks in accordance with local codes and all listed procedures in the latest edition of *the National Fuel Gas Code ANSI Z223.1/NFPA 54*.

### **⚠DANGER**

**Do not use an open flame to check for gas leaks. Be sure there are no sparks or open flames in the area while you check for gas leaks. This will result in a fire or explosion which can cause serious bodily injury or death, and damage to property.**

## Typical 20 LP propane gas supply Installation

We strongly recommend that you use the Summit® Built-In Tank Cabinet (#21280) for installations using a 20 lb LP cylinder, mounted remotely in an "island" structure.

The Summit® Built-In Tank Cabinet is a CSA listed accessory for installing a remote mounted 20 lb LP cylinder, in an "island" structure. Summit® Built-In Tank Cabinet has a hose and regulator assembly and gas connections, for connecting a remote mounted LP cylinder to the Summit® Built-In gas grill. The hose and regulator is listed as a required part of the CSA listed Summit® Built-In gas grill.

The Summit® Built-In Tank Cabinet also meets the requirements for venting, tank retention and separation of the LP cylinder from a heat source as outlined in the ANSI Standard for Outdoor Cooking Gas Appliances, Z21.58/CSA 1.6 for LP enclosures.

The Summit® Built-In Tank Cabinet has its own installation guide.

If you do not use the Summit® Built-In Tank Cabinet, you need to hire a licensed contractor or licensed plumber and they need to follow the requirements described in the ANSI Standard for Outdoor Cooking Gas Appliances, Z21.58/CSA 1.6 for LP enclosures.

The requirements described in the Standard for Outdoor Cooking Gas Appliances, Z21.58/CSA 1.6 are as follows; A remote enclosure for an LP gas cylinder shall be ventilated by openings at both the upper and lower levels of the cylinder. This shall be accomplished by one of the following:

- a). One side of the remote LP cylinder enclosure shall be completely open; or
- b). If the remote LP cylinder enclosure is designed to have four sides, a top and a bottom, ventilation is required for the remote LP cylinder enclosure;
  - 1). There should be at least two ventilation openings, (a hole or group of holes, for the purpose of ventilation) in the sidewalls of the enclosure. The openings should be located within 5 inches (127mm) of the top of the enclosure. The ventilation openings should be equally sized and spaced at a minimum of 90 degrees, and be unobstructed. The openings shall have a total free open area of not less than 20 square inches. (This relates to 1 square inch of ventilation area, per pound of stored fuel capacity).
  - 2). Ventilation openings (a hole or group of holes, for the purpose of ventilation) should be provided at floor level. The ventilation openings should have a total free area of not less than 10 square inches. (This relates to square of ventilation area, per pound of stored fuel capacity). There should be at least two ventilation openings if the ventilation openings at floor level are in the sidewall. The ventilation openings should be within 5 inches (127mm) of the floor. The ventilation openings should be of equal size and be spaced at a minimum of 90 degrees, and should be unobstructed.
  - 3). The minimum size of the ventilation hole (s) should not be less than inch.
  - 4). The ventilation openings in the sidewalls should not allow venting into the empty or "hollow" area of the "island". If a gas leak should occur or the LP cylinder should vent in the LP cylinder enclosure, the gas should not be allowed to vent or migrate into the empty or "hollow" area of the "island". Ventilation openings in the sidewalls of the enclosure should only communicate with the outside of the "island" structure, so that the gas can dissipate outside of the "island" structure.
- c). If the remote LP cylinder enclosure has four sides, a top and a bottom, and is intended for installation in a built-in "island" enclosure;

- 1). At least one ventilation opening (a hole or group of holes, for the purpose of ventilation) needs to be on one side of the enclosure that communicates with the outside of the “island” structure. If a gas leak should occur or the LP cylinder should vent in the LP cylinder enclosure, the gas should not be allowed to vent or migrate into the empty or “hollow” area of the “island”. Ventilation openings should only communicate with the outside of the “island” structure, so that the gas can dissipate outside of the “island” structure. The ventilation opening should be located within 5 inches (127mm) of the top of the enclosure, and should have a total free area of 20 square inches. (This relates to 1 square inch of ventilation area, per pound of stored fuel).
- 2). At least one ventilation opening (a hole or group of holes, for the purpose of ventilation) needs to be on one side of the enclosure that communicates with the outside of the “island” structure, at the bottom. If a gas leak should occur or the LP cylinder should vent in the LP cylinder enclosure, the gas should not be allowed to vent or migrate into the empty or “hollow” area of the “island”. Ventilation openings should only communicate with the outside of the “island” structure, so that the gas can dissipate outside of the “island” structure. The ventilation opening should be located within 5 inches (127mm) of the bottom of the enclosure, and should have a total free area of 10 square inches. (This relates to 1/4 square inch of ventilation area, per pound of stored fuel).
- 3). The minimum size of the ventilation hole (s) should not be less than 1/2 inch.
- d). The remote LP cylinder enclosure should be constructed with non-combustible materials. The remote LP cylinder enclosure should isolate the LP cylinder from the burner compartment, so that it provides shielding from radiation, be a flame barrier and provide protection from foreign material such as hot drippings.
- e). There should be a minimum of 2 inches (50.8mm) between the ground and the floor of the remote LP cylinder enclosure.
- f). The LP cylinder valve should be readily accessible for hand operation. A door on the remote LP cylinder enclosure to gain access to the LP cylinder valve is acceptable, provided it is non- locking and can be opened without the use of tools.

If your, licensed contractor or licensed plumber, builds an LP cylinder enclosure following the guidelines in the ANSI Standard for Outdoor Cooking Gas Appliances, Z21.58 CSA 1.6, you need to order kit number (#21287), which will contain the hose and regulator assembly, mounting bracket for the regulator, connection fittings and LP tank bracket for retaining the LP cylinder that must be used with the Summit® Built-In gas grill. The hose and regulator in the kit (#21287) is listed as part of the CSA listed Summit® Built-In gas grill.

**⚠DANGER**

**Use of any other hose and regulator assembly could be dangerous, and may not provide adequate gas supply to the Summit® Built-In gas grill, and could result in a fire or an explosion causing serious bodily injury or death and damage to property.**

**⚠DANGER**

**Failure to use the the Summit® Built-In Tank Cabinet for a 20 lb cylinder or failure to build a LP cylinder enclosure for a 20 lb cylinder following the requirements for ventilation, cylinder retention and separation of the LP cylinder from a heat source, listed in the ANSI Standard for Outdoor Cooking Gas Appliances, ANSI Z21.58 CSA 1.6, could be dangerous, and could result in a fire or an explosion causing serious bodily injury or death and damage to property.**

**If you do not follow the DANGER statements exactly, the Warranty on the Summit® Built-In gas grill will be voided.**

# GAS SUPPLY

## CONNECT GAS SUPPLY

A 5/8" inch corrugated gas line is supplied with the grill. This line needs to pass through the gas inlet opening to the main gas supply.

- 1) Connect the corrugated gas line to the manifold located on the right hand side of grill under the control panel.

**Note: Leave an access in the "island" structure for gas supply and regulator service not inside the grill structure. Weber® has a gas line and regulator access door (part # 36311) available from your dealer or call Customer Service at 1-847-446-1071.**

The corrugated line passes through the "Island Structure" cavity to the regulator connection inside the Summit® Built-In tank cabinet (#21280) or the hose and regulator connection from kit # 21287. (Shown below)

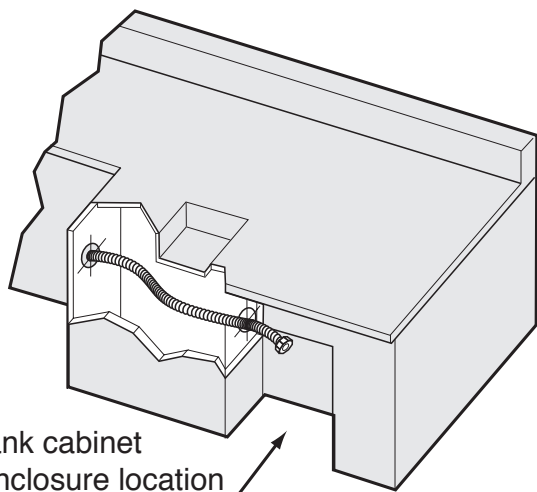

## VENTILATION

**⚠WARNING: Air holes must be provided in the structure at the top and bottom to provide ventilation in the event of a gas leak.**

Air holes can be located in a low visibility area and should be protected by screening material to prevent rodents and insects from entering the structure. Air holes will also help dry moisture.

Summit® Built-In cabinet vents (part # 36312 / #61429) are available from your dealer or call Customer Service at 1-800-466-1071.

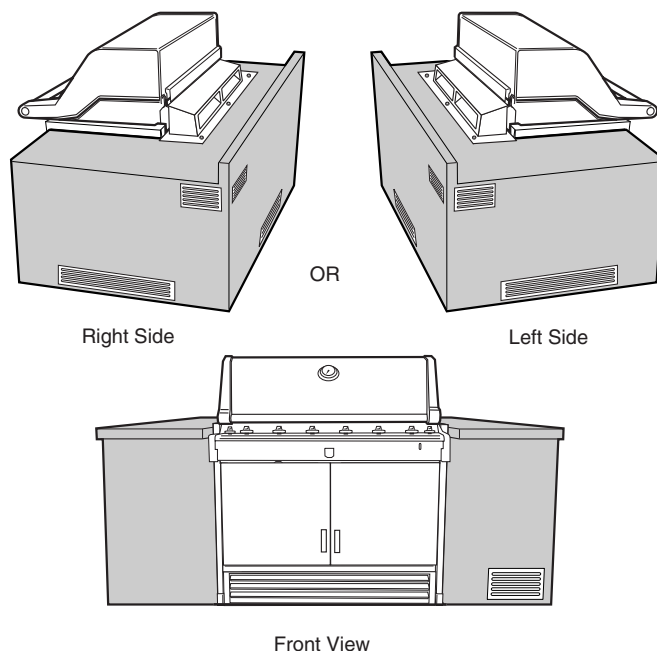

**Note: These drawings are only a reference.**

- Cross ventilation must be incorporated in the supporting structure. We recommend a minimum of 100 square inches of venting per side.
- Vents should be on two sides of the structure.
- The above drawings are for reference only.
- Location of the vents should be from the center, outward.
- Locate the vents at both the bottom of the structure and at the top of the structure.
- The bottom vents should be as close to ground level as possible. Make sure the vent area is not blocked by interior supports of the structure.
- We recommend vents with screens.
- Access doors to the structure are not considered vents.
- Clean the vents periodically.

**⚠DANGER: Failure to follow recommended minimum venting instructions can cause gas to collect in the structure in the event of a gas leak. This may result in a fire or an explosion which can cause serious bodily injury or death, and damage to property.**