







































## Step 16

### Fill LP tank

*Note - The LP tank manufacturer is responsible for the materials, workmanship and performance of the tank. If the tank has a defect, malfunctions, or you have a question regarding the tank, call the tank manufacturer's customer service center. The phone number is on the warning decal which is permanently attached to the tank. If the tank manufacturer has not resolved the issue to your satisfaction, then call Weber-Stephen Products Co., Customer Service Center.*

Take the LP tank to an RV center (or some other source of LP gas) to fill the tank with 20 pounds of liquid propane.

**⚠WARNING:** We recommend that your LP tank be filled at an authorized LP gas dealer by a qualified attendant, who fills the tank by weight.

### IMPROPER FILLING IS DANGEROUS.

Tell your LP dealer that this is a new LP tank. The air must be removed from a new LP tank before the initial filling. Your LP tank dealer is equipped to do this.

**⚠CAUTION:** If you exchange your LP tank, make sure you get a similar tank in return. Your LP tank is equipped with a quick-disconnect valve. Other LP tanks are not compatible with your barbecue connection.

The LP tank must be installed, transported and stored in an upright position. LP tank should not be dropped or handled roughly.

Never store or transport the LP tank where temperatures can reach 125° Fahrenheit (too hot to hold by hand – for example: do not leave the LP tank in a car on a hot day).

For full instructions on safe handling of LP tanks, see Section "Operating Instructions".

## Step 17

### Check that burners are off

You will need: one burner control knob.

Valves are shipped in the off position, but you should check to be sure. Put the knob on each valve. Check by pushing down and turning clockwise. If they do not turn, they are OFF. Proceed to the next step. Figure 23.

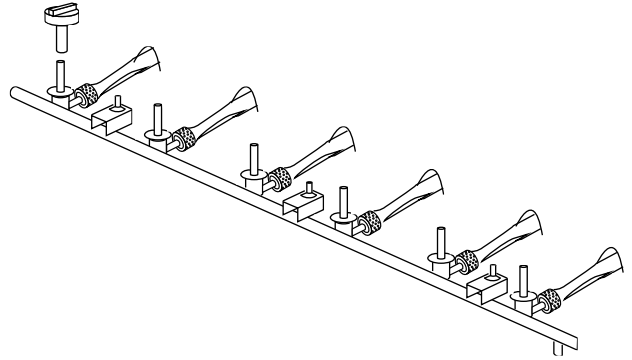

Figure 23

## Step 18

### Connect LP tank

You will need: hose clamp and 1/4-20 x5/8 screw, regular screwdriver.

**⚠WARNING:** Make sure that the LP tank valve is closed. Close by turning clockwise.

Hook the LP tank onto the fuel scale. Loosen the tank lock wing nut. Swing the tank lock down. Tighten the wing nut. Figure 24.

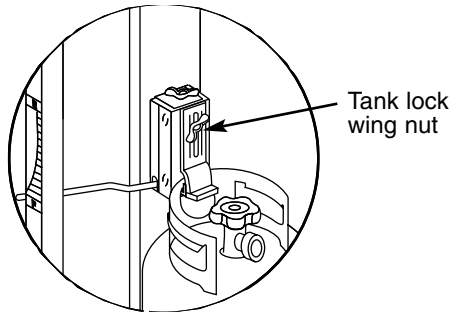

Figure 24

Put the clamp over the hose. Insert the screw through the hose clamp and into the threaded hole in the side of the wheel frame leg. Tighten. Figure 25.

**⚠WARNING:** Hose must be in front of the wheel frame leg.

**⚠WARNING:** Make sure that the hose cannot come in contact with the cooking box assembly.

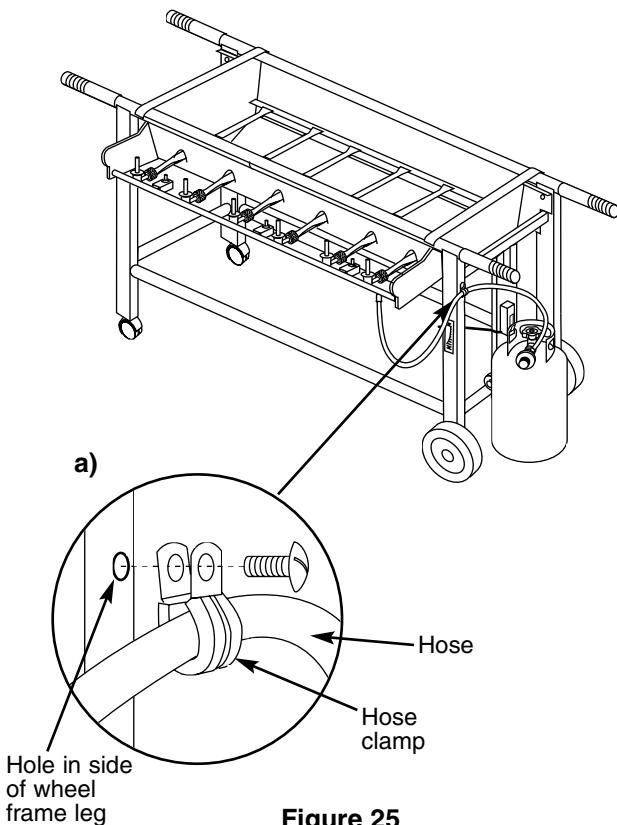

Figure 25

The hose and regulator are connected in the following manner:

Slide back the collar of the quick disconnect on the tank valve. Push the male fitting of the regulator into the quick disconnect, and maintain pressure. Slide the collar closed. Figure 26 (a). Figure 26 (b) shows the quick disconnect engaged and various components of the tank and regulator. Regulator vent hole should be at 3, 6, or 9 o'clock. It should not be pointed up. Figure 26 (c).

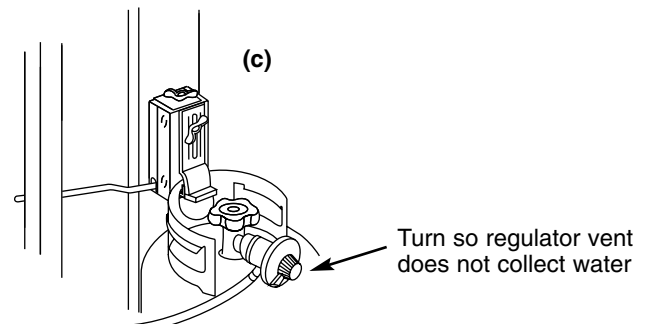
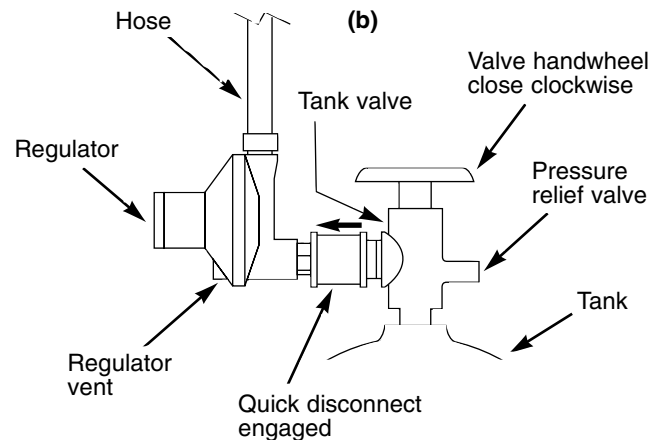
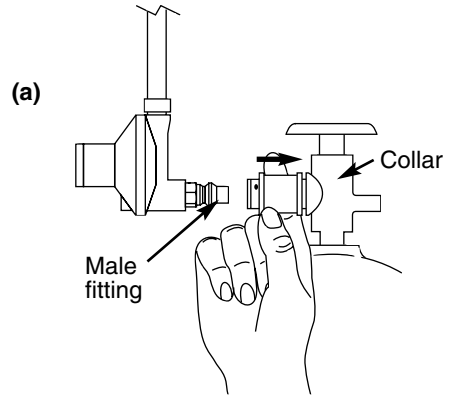

Figure 26

## Step 19

### Check for gas leaks

#### **⚠ DANGER ⚠**

**Do not use an open flame to check for gas leaks. Be sure there are no sparks or open flames in the area while you check for leaks. This will result in a fire or explosion which can cause serious bodily injury or death and damage to property.**

**⚠WARNING:** You should check for gas leaks every time you disconnect and reconnect a gas fitting.

*Note: All factory made connections have been thoroughly checked for gas leaks. The burners have been flame tested. As a safety precaution you should recheck all fittings for leaks before using your Weber Gas Barbecue. Shipping and handling may have loosened or damaged a gas fitting.*

You will need: a soap and water solution and a rag or brush to apply it.

To perform leak checks: Open tank valve by turning the tank valve handwheel counterclockwise.

Figure 26.

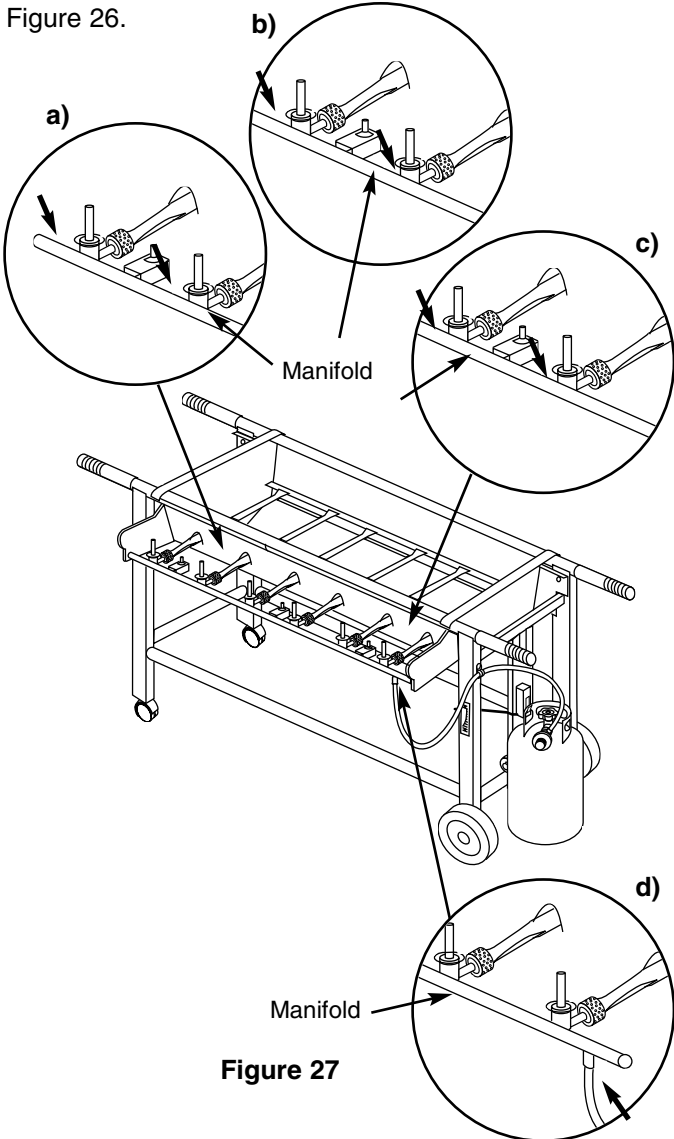

Check for leaks by wetting the connections with the soap and water solution and watching for bubbles. If bubbles form or if a bubble grows there is a leak.

**⚠WARNING:** Do not ignite burners while leak checking.

Check:

- Left valves to manifold connection. Figure 27 (a).
- Center valves to manifold connection. Figure 27 (b).
- Right valves to manifold connection. Figure 27 (c).
- Hose to manifold connection. Figure 27 (d)

**⚠WARNING:** If there is a leak at connection 27 (d) turn OFF the gas and retighten the fitting with a wrench and recheck for leaks with soap and water solution.

**If a leak persists after retightening the fitting, turn OFF the gas. DO NOT OPERATE THE BARBECUE. Contact your dealer.**

- Hose to regulator connection. Figure 28 (a).
- Regulator to tank connection. Figure 28 (b).

**⚠WARNING:** If there is a leak at connections 27 (a), 27 (b), 27 (c) or 28 (a), turn OFF the gas. Do not operate the barbecue. Contact your dealer.

**⚠WARNING:** If there is a leak at connection 28 (b) retighten and recheck for leaks with soap and water.

When leak checks are complete, turn gas supply OFF at the source and rinse connections with water.

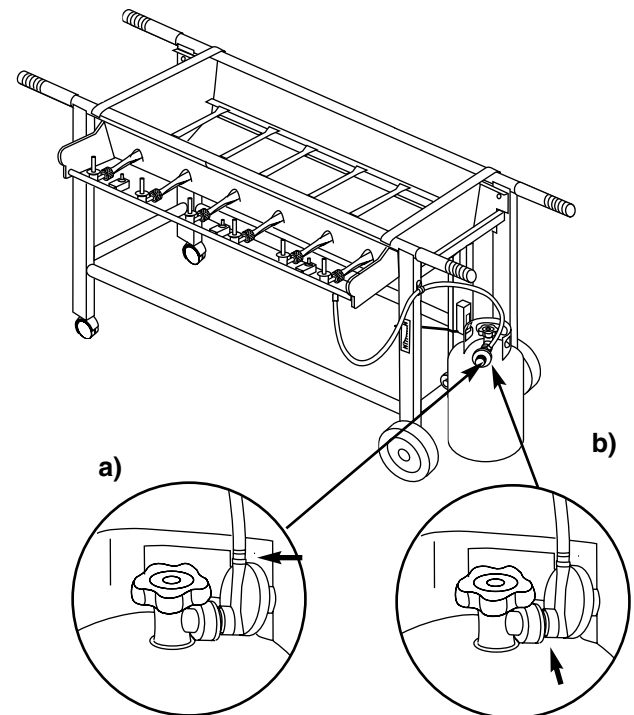

## Step 20

### Install Flavorizer Bar/cooking grill support

You will need: two Flavorizer Bar/cooking grill supports.

Slide one Flavorizer Bar/cooking grill support behind the bracket in the rear of the cooking box assembly.

Figure 29 (a).

Slide the second Flavorizer Bar/cooking grill support behind the brackets at the front of the cooking box assembly. Figure 29.

Slides behind this bracket

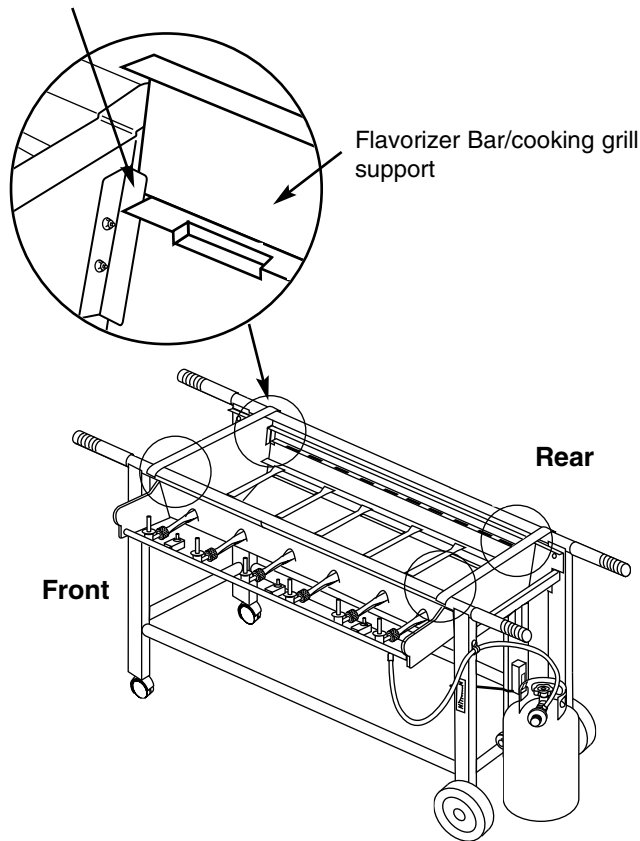

Figure 29

## Step 21

### Install Flavorizer Bars

You will need: eleven flavorizer bars.

Set the Flavorizer bars front to back over the burners in the slots of the Flavorizer Bar/cooking grill support.

Figure 30 (a).

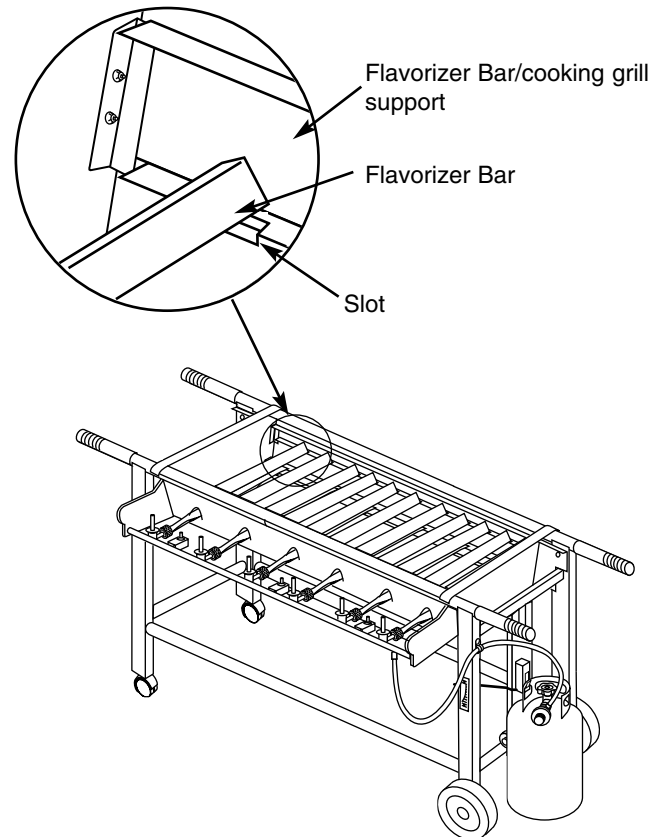

Figure 30

## Step 22

### Install splash guards

You will need: two splash guards

Position splash guard, flanges to the rear, at the back of the cooking box assembly. Figure 31 (a). Insert both wire ends into the mounting holes in the cooking box. Figure 31.

*Note: You will have to bend the splash guards slightly to fit into the mounting holes.*

Position the second splash guard, flanges facing you, at the front of the cooking box assembly. Insert both wire ends into the mounting holes in the cooking box. Figure 31.

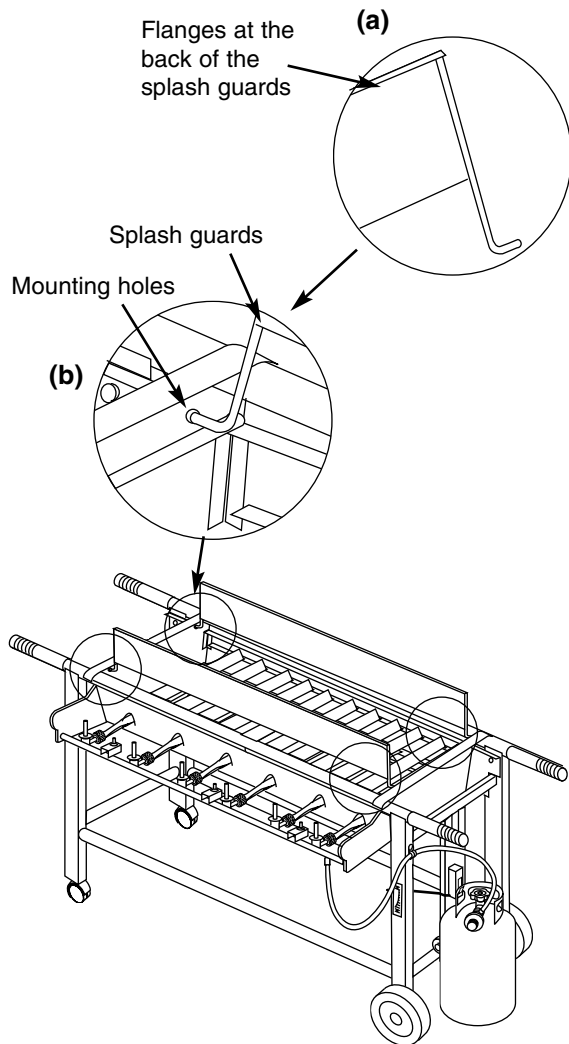

Figure 31

Splash guards open for use. Figure 32.

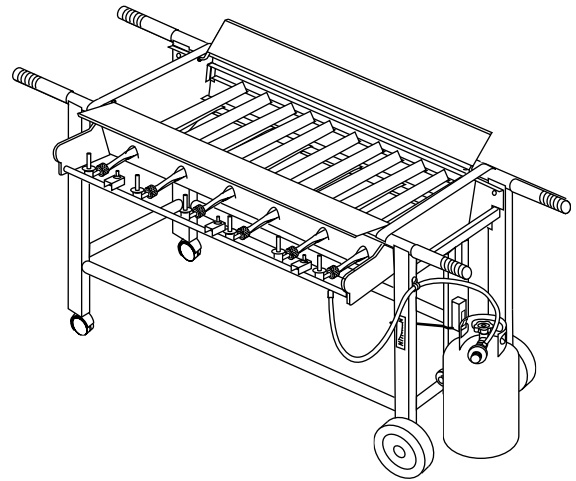

Figure 32

Splash guards closed for storage. Figure 33.

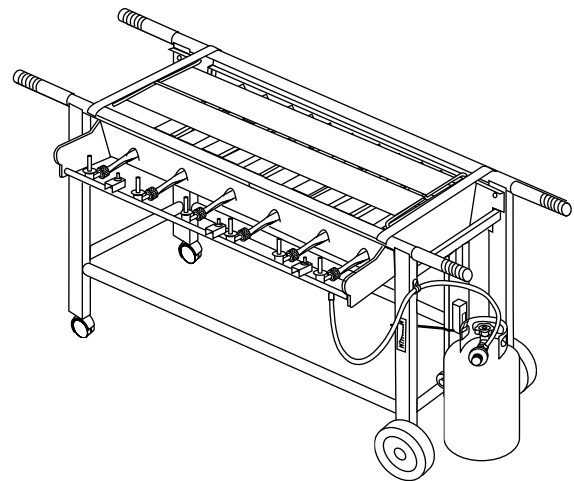

Figure 33

## Step 23

### Install Cooking Grills and Griddle

You will need: two cooking grills and one griddle.

Set the griddle on top of the Flavorizer Bar/cooking grill support. Figure 34.

**⚠CAUTION:** The drain hole of the griddle needs to be toward the front.

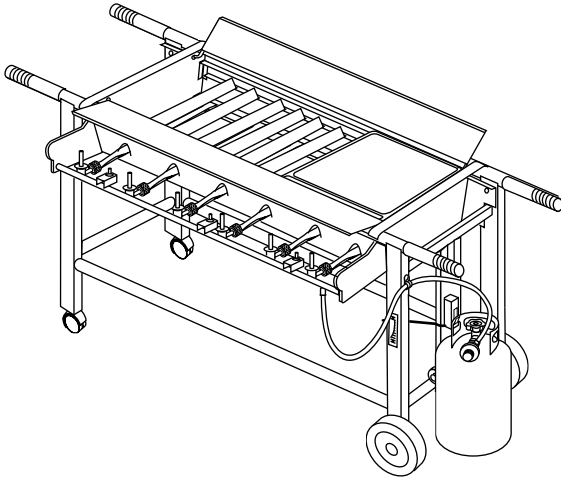

Figure 34

The open “U” of the cooking grill goes down. Set both cooking grills in place next to the griddle. Figure 35.

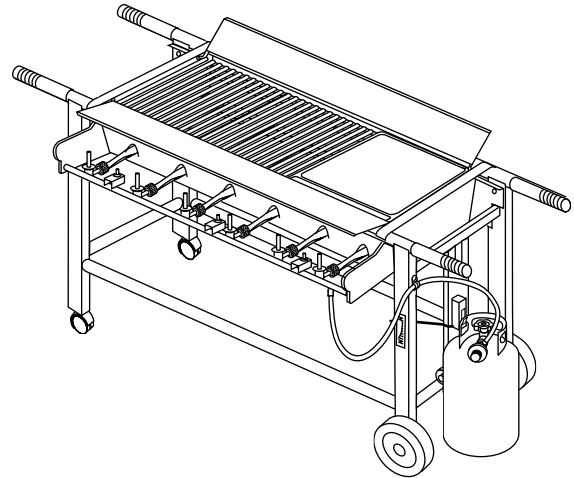

Figure 35

## Step 24

### Install left work surface and glides

You will need: left work surface, two nylon (plastic) glides, two Phillips head 1/4-20 x 1 inch machine screws and a Phillips screwdriver.

Set the left work surface over the top of the cooking box and the top frame rails. Figure 36. The left work surface will cover half of the handles on the left side.

Position the glide as shown in figure 36 (a). Align the front hole in the left work surface and the glide.

Thread screw in and tighten with a Phillips screwdriver. Figure 36 (b).

Repeat the procedure with the second glide at the rear of the left work surface.

**⚠WARNING: The load limit for the work surface is 25 pounds.**

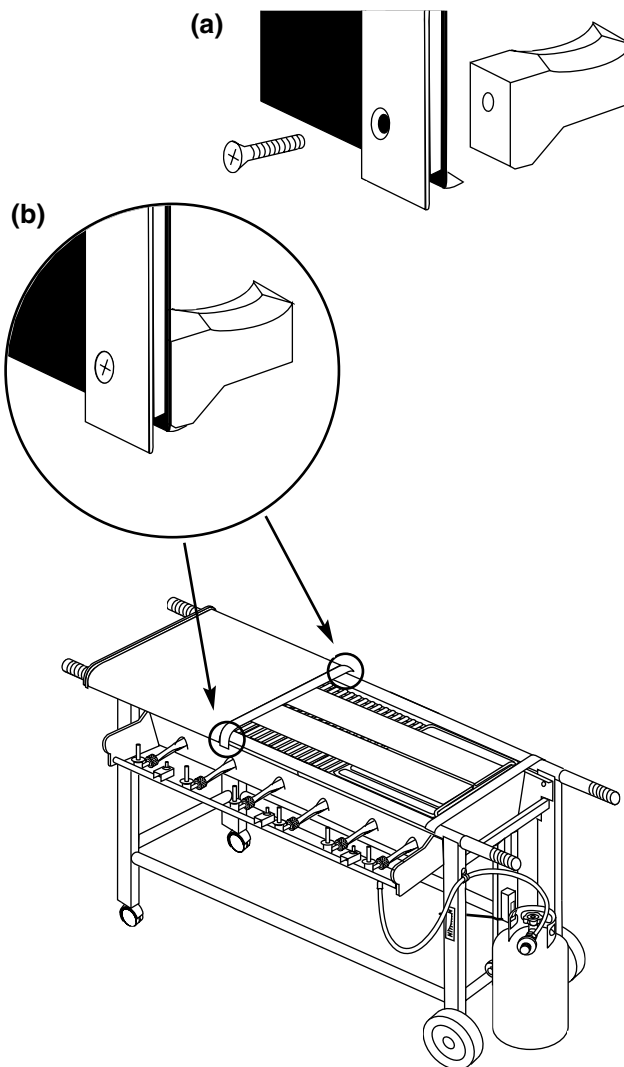

Figure 36

## Step 25

### Install right work surface and glides

You will need: right work surface, two nylon (plastic) glides, two Phillips head 1/4-20 x 1 inch machine screws and a Phillips screwdriver.

Set the right work surface over the top of the cooking box and the top frame rails. Figure 37. The right work surface will cover half of the handles on the right side.

Position the glide as shown in figure 37 (a). Align the front hole in the right work surface and the glide.

Thread screw in and tighten with a Phillips screwdriver. Figure 37 (b).

Repeat the procedure with the second glide at the rear of the right work surface.

**⚠WARNING: The load limit for the work surface is 25 pounds.**

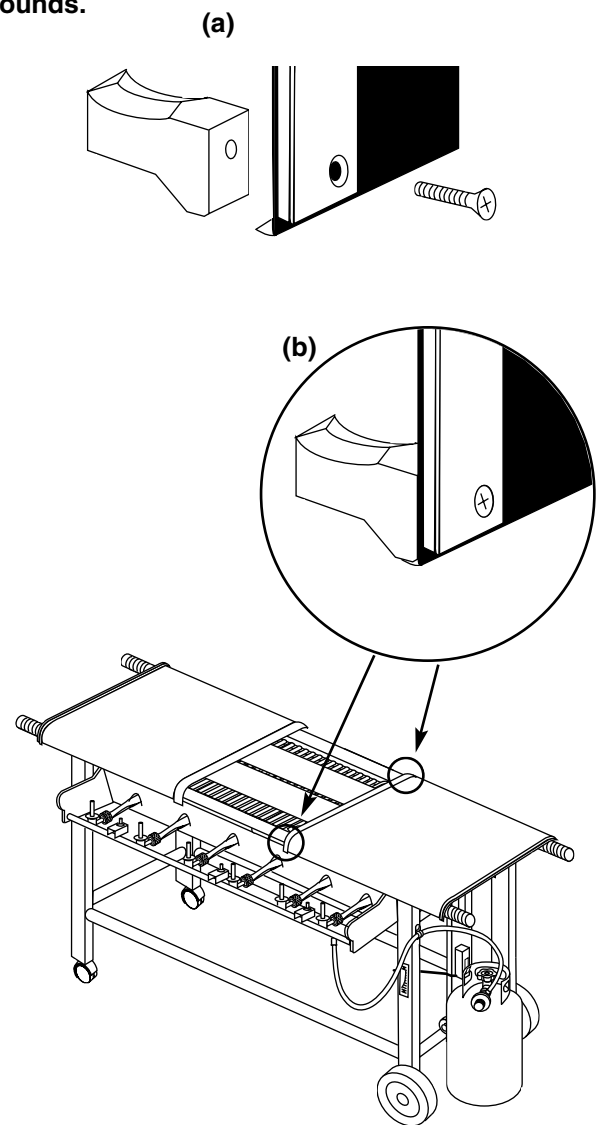

Figure 37

## Step 26

### Reinstall front panel, control panel and burner control knobs

You will need: control panel, front panel, and four burner control knobs.

With the Weber logo to the left, slide front panel down into place. Figure 38.

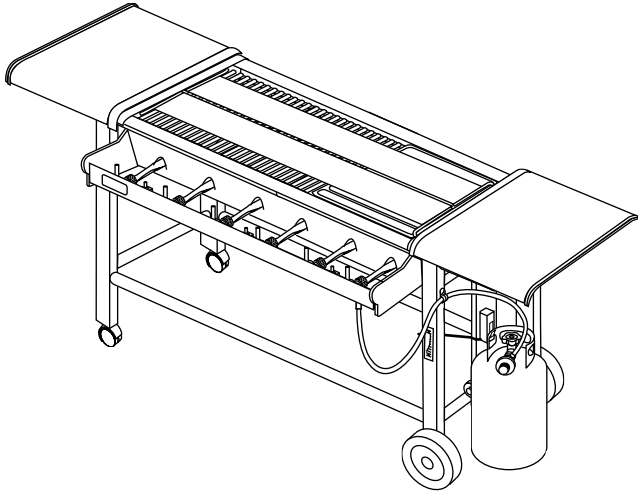

Figure 38

Pull igniter buttons up until they stay in the up position. Place the control panel into the grooves on either side of the front of the cooking box. Push the control panel into place, using even pressure while pushing. Figure 39 (a).

Use your fingers to lift the front edge of the control panel slightly and set it into the recess on both sides of the cooking box. Figure 39.

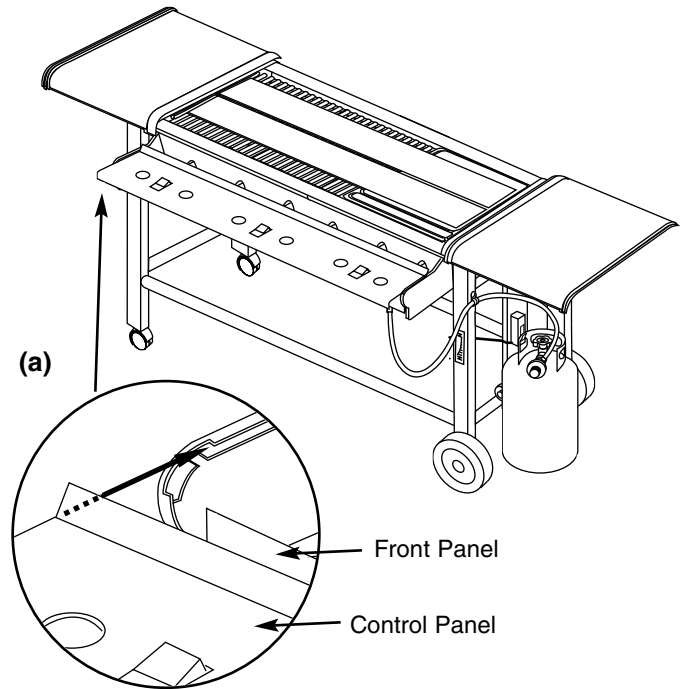

Figure 39

Push on the burner control knobs. Figure 40.

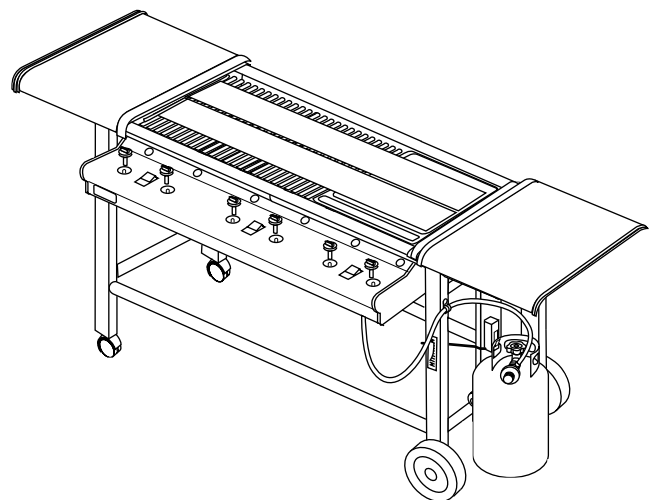

Figure 40

## Step 27

### Install bottom tray

You will need: Bottom tray, catch pan holder, catch pan, and one drip pan.

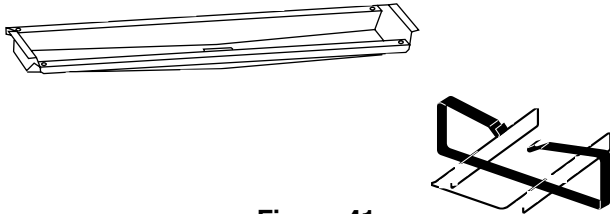

Figure 41

*Note: It may be easier to install the catch pan holder by removing the catch pan from the holder.*

Hook the ends of the catch pan holder into the hole in the bottom tray. Figure 42.

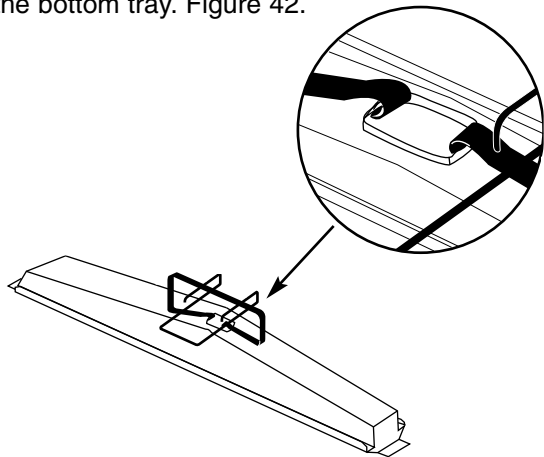

Figure 42

Slide the bottom tray into the mounting slots under the bottom of the cooking box with the finger grip of the catch pan toward you. Figure 43.

**⚠CAUTION: Do not line the bottom tray with aluminum foil. It can cause grease fires by trapping the grease and not allowing grease to flow into the catch pan.**

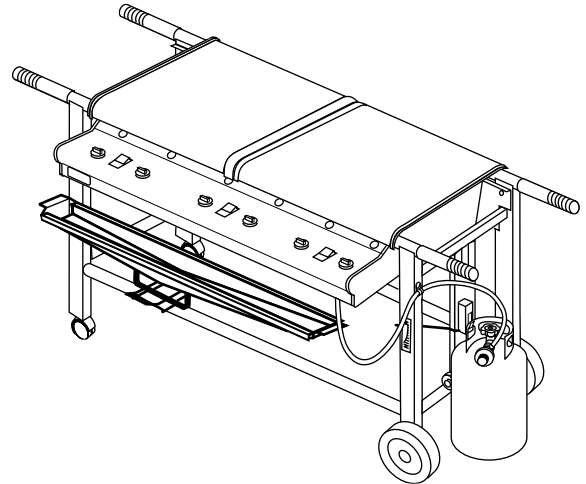

Figure 43

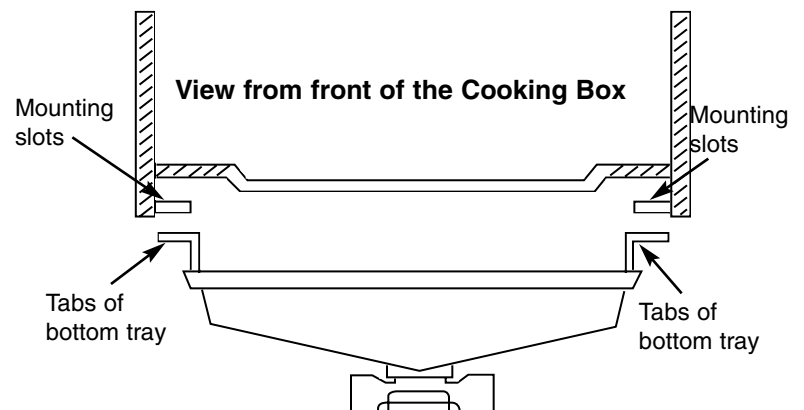

Figure 44

Put the foil drip pan into the catch pan.

## Step 28

### Add accessory rack

You will need: accessory rack.

Set the bottom rack between the two bottom connectors. Figure 45.

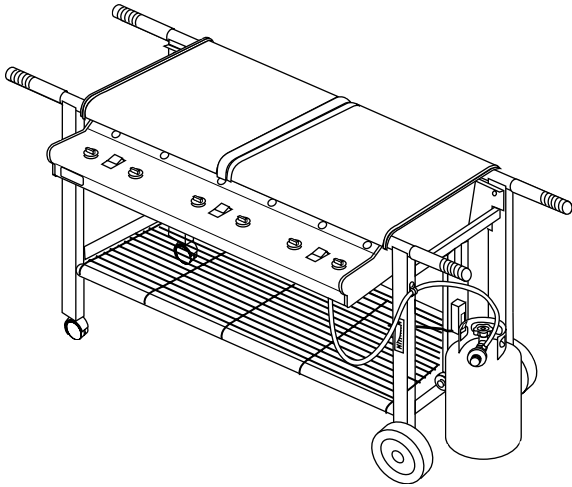

**Figure 45**

# OPERATING INSTRUCTIONS

## Lighting

**EACH HEAT ZONE OPERATES INDEPENDENTLY.**

Summary lighting instructions are on the control panel.

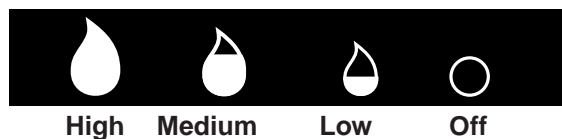

### ⚠ DANGER ⚠

Failure to open sliding work surfaces while igniting the barbecue, or not waiting 5 minutes to allow the gas to clear if the barbecue does not light, may result in an explosive flame-up which can cause serious bodily injury or death.

### Crossover Ignition System

*Note - The Crossover Ignition System ignites the Left burner of each heat zone with a spark from the igniter electrode inside the Gas Catcher Ignition Chamber. You generate the energy for the spark by pushing the Crossover Ignition Button until it clicks.*

**⚠WARNING:** Check hose before each use of barbecue for nicks, cracking, abrasions or cuts. If the hose is found to be damaged in any way, do not use the barbecue. Contact your dealer.

Crossover Ignition System

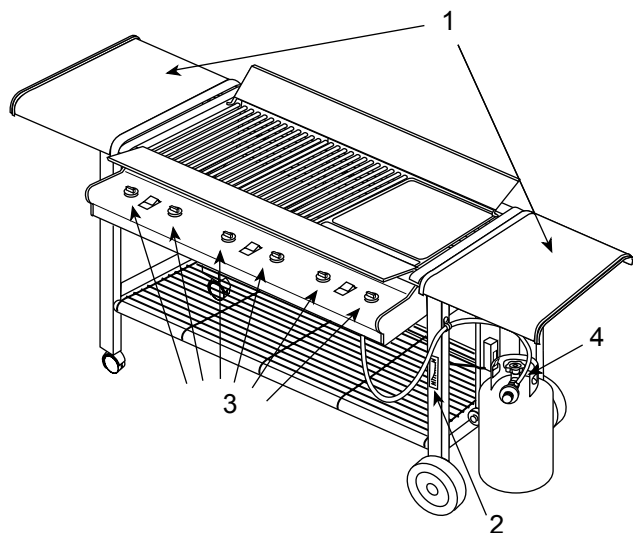

Figure 1

- 1) Open the sliding work surfaces and splash guards. Figure 1.
- 2) Check that the fuel scale reads more than "E".  
*Note - E = empty; F = full.*
- 3) Make sure all burner control knobs are OFF. (Push each burner control knob down and turn clockwise.)

**⚠WARNING:** The burner control knobs must be in the OFF position before turning on the LP tank valve. If they are not in the OFF position, when you turn on the LP tank valve, the excess flow control will activate, limiting the flow of gas from the LP tank. If this should occur, turn OFF the LP tank valve and burner control knobs and start over.

### ⚠ DANGER ⚠

When the excess flow control is activated, a small amount of gas is still flowing to the burners. After turning OFF the tank and burner control knobs, wait at least 5 minutes for the gas to clear before attempting to light the barbecue. Failure to do so may result in an explosive flame-up which can cause serious bodily injury or death.

- 4) Turn the tank on by turning the tank valve counterclockwise.
- ⚠WARNING:** Do not lean over open barbecue. Keep your face and body at least one foot away from the matchlight hole when lighting the barbecue.
- 5) Select Heat Zone.
  - 6) Push LEFT burner control knob down and turn to START / HI.
  - 7) Push the Crossover Ignition Button several times, so it clicks each time.
  - 8) Check that the burner is lit by looking through the matchlight hole above the burner control knob.
- ⚠WARNING:** If the burner does not light, turn the LEFT burner control knob to OFF and wait 5 minutes to let the gas clear before you try again or try to light with a match.
- 9) After the LEFT burner is lit you can turn on the RIGHT burner.

*Note - Always light the LEFT burner first. The RIGHT burner ignites from the LEFT burner.*

## To Extinguish

Turn gas supply OFF at the source, then push down and turn each burner control knob clockwise to OFF.

# Manual Lighting

EACH HEAT ZONE OPERATES INDEPENDENTLY.

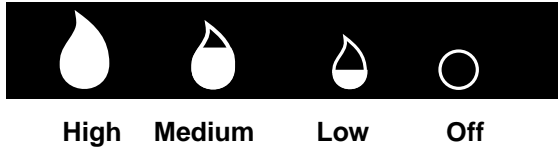

## ⚠ DANGER ⚠

Failure to open sliding work surfaces while igniting the barbecue, or not waiting 5 minutes to allow the gas to clear if the barbecue does not light, may result in an explosive flame-up which can cause serious bodily injury or death.

- 1) Open the sliding work surfaces and splash guards. Figure 2.
- 2) Check that fuel scale reads more than "E".  
*Note - E = empty; F = full.*
- 3) Make sure all burner control knobs are turned OFF. (Push each burner control knob down and turn clockwise.)

**⚠WARNING:** The burner control knobs must be in the OFF position before turning on the LP tank valve. If they are not in the OFF position, when you turn on the LP tank valve, the excess flow control will activate, limiting the flow of gas from the LP tank. If this should occur, turn OFF the LP tank valve and burner control knobs and start over.

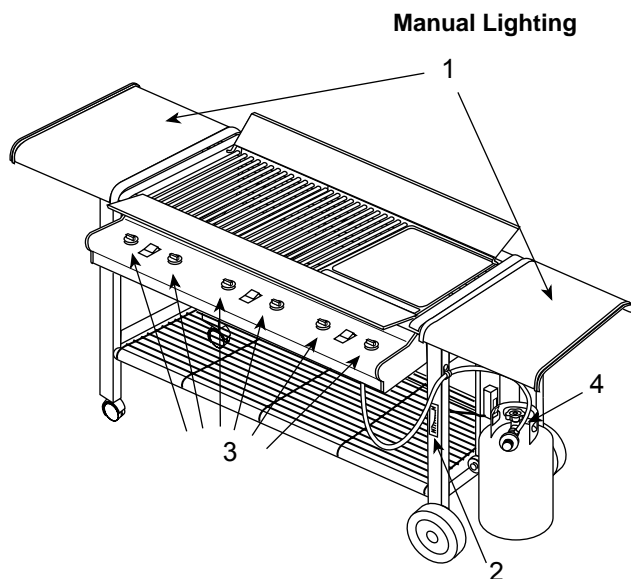

Figure 2

## ⚠ DANGER ⚠

When the excess flow control is activated, a small amount of gas is still flowing to the burners. After turning OFF the tank and burner control knobs, wait at least 5 minutes for the gas to clear before attempting to light the barbecue. Failure to do so may result in an explosive flame-up which can cause serious bodily injury or death.

- 4) Turn on gas supply.
- 5) Select heat zone.
- 6) Put a match in the match holder and strike the match.
- 7) Push LEFT burner control knob down and turn to H (high).

**⚠WARNING:** Do not lean over open barbecue. Keep your face and body at least one foot away from the matchlight hole when lighting the barbecue.

- 8) Insert match holder and lit match through matchlight hole to ignite LEFT burner.

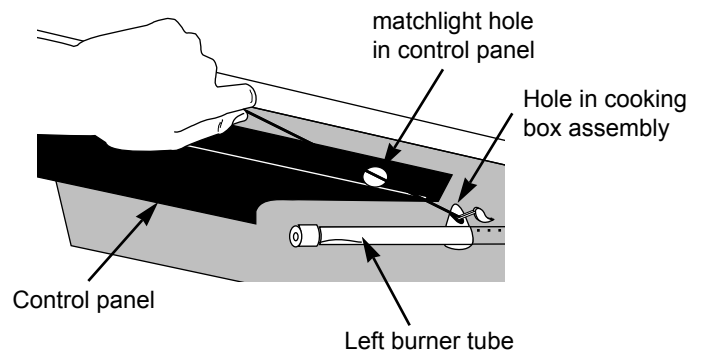

Figure 3

- 9) Observe if LEFT burner has ignited by looking through matchlight hole.

**⚠WARNING:** If LEFT burner fails to ignite turn LEFT burner control knob to OFF and wait 5 minutes before attempting to ignite again.

- 10) After the LEFT burner is lit you can turn on the RIGHT burner.

*Note: Always light the LEFT burner first. The RIGHT burner ignites from the LEFT burner.*

## To Extinguish

Turn gas supply OFF at the source, then push down and turn each burner control knob clockwise to OFF.

## Cooking

---

The Weber Gas Barbecue should not be moved when operating or hot.

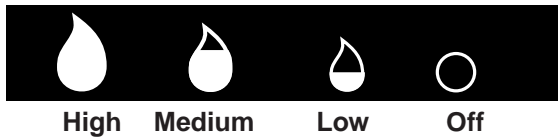

You can adjust the LEFT and RIGHT burners as desired. The control settings High (H), Medium (M), Low (L), or Off (O) are described in your Weber cookbook. The cookbook uses these notations to describe the settings of the LEFT and RIGHT burners.

*Note: Cooking conditions may require the adjustment of the burner controls.*

If burners go out during cooking, turn off all burners and wait 5 minutes before relighting.

**⚠CAUTION:** Check the bottom tray for grease build-up before each use. Remove excess grease to avoid a grease fire in the bottom tray.

## Using the Cooking Grates

---

To preheat, after lighting, turn both burners to high (HH). Preheating will take 10 to 15 minutes depending on conditions such as air temperature and wind.

See your Weber cookbook for detailed cooking instructions.

**Drippings and grease** - The Flavorizer Bars are designed to "smoke" the right amount of drippings for flavorful cooking. Excess drippings and grease accumulate in the catch pan under the bottom tray. Disposable foil liners are available that fit the catch pan.

## Using the Cast Iron Griddle

---

### WARNINGS:

- ⚠ Use heat-resistant barbecue mitts or gloves when handling or cooking on the griddle.
- ⚠ Do not wear clothing with loose flowing sleeves while using the griddle.
- ⚠ Do not remove the griddle until it is cold.
- ⚠ Use caution when cooking foods with high fat content, such as chops, bacon or sausage.
- ⚠ Follow all safety instructions provided with your barbecue.
- ⚠ Do not drop cast iron griddle, it will break.
- ⚠ Prior to storing, grease very lightly with solid vegetable oil or vegetable cooking spray, then wipe dry with a paper towel. Store in a dry place.

### First Time Use

---

Wash thoroughly with a mild dishwashing liquid to remove the wax coating used for protection in shipping. Rinse with hot water and dry completely with a soft cloth or paper towel. NEVER ALLOW TO DRAIN DRY, OR WASH IN A DISHWASHER. You must season the griddle before first use to prevent rust and keep foods from sticking.

### Seasoning The Griddle

---

Spread a thin coating of solid vegetable oil over entire surface of the cast iron griddle with a paper towel. Be certain the entire surface, including all corners, has been coated thoroughly. (Do not use salted fat such as margarine or butter.)

Season the cast iron griddle in your oven. Put griddle on top oven rack. Place aluminum foil on lower oven rack to catch any drippings. Bake in a moderate oven for 1½ hours. If you are not planning to use the oven for several hours — you can turn oven off after seasoning and leave griddle in oven to cool to room temperature.

*Note: If oven is to be used immediately after seasoning use heat-resistant barbecue mitts or gloves to remove griddle from oven while HOT. Place griddle on a heat-resistant surface and allow it to cool to room temperature.*

**Important Note:** To prevent rusting the cast iron griddle should be reseasoned frequently. If rust occurs, clean with a steel wool scouring pad, rinse with hot water and dry. Coat with a solid vegetable oil or a vegetable cooking spray and heat in grill or oven as indicated above.

## Maintenance

---

Always clean the griddle immediately after each use with boiling hot water and a brush. Rinse and dry thoroughly. If there is a lot of food sticking to the surface of the griddle it may be cleaned with a steel wool scouring pad. Rinse well with hot water and reseason per instructions in grill or oven. Prior to storing, grease very lightly with a solid vegetable oil or a vegetable cooking spray, then wipe dry with a paper towel. Store in a dry place.

## Reseasoning

---

- After each use the griddle may be reseasoned by coating with a solid vegetable oil.
- A vegetable cooking spray may be used as a convenient method for quick reseasoning.

## Tips

---

- The cast iron griddle will turn black with use. The pores of the iron will be sealed, providing a durable coating that helps to prevent foods from sticking. The griddle will further season with use. Regular applications of solid vegetable oil or vegetable cooking spray will improve its resistance to rust.
- Rust, a metallic taste or discolored foods are signs of improper or inadequate seasoning or may result from cooking acidic foods. If this occurs, wash thoroughly and reseason.
- Since cast iron holds heat well, you will not need to use extremely high cooking temperatures. Best results are obtained with medium to medium-high heat. Do not overheat.
- As with all cast iron, the more the use, the easier the maintenance.

## Cooking with the Griddle

---

To preheat, after lighting, turn both burners to high (HH). Preheating will take 10 to 15 minutes depending on conditions such as air temperature and wind.

Your Weber Gas Barbecue is an energy efficient appliance. It operates at a low B.T.U. rate for economy.

See your Weber cookbook for detailed cooking instructions.

## Periodic Cleaning

---

**⚠CAUTION:** Turn your Weber Gas Barbecue OFF and wait for it to cool before cleaning.

**⚠CAUTION:** Do not clean your Flavorizer Bars or cooking grills in a self-cleaning oven. Replacement cooking grills and griddles and Flavorizer Bars are available through your retailer.

**Outside surfaces** - Use a warm soapy water solution.

**⚠CAUTION:** Do not use oven cleaner, abrasive cleansers (kitchen cleansers) cleaners that contain citrus products or abrasive cleaning pads on barbecue or cart surfaces.

**Bottom tray** - Remove excess grease and then wash with warm soapy water.

**Flavorizer Bars and Cooking Grills** - Clean with a suitable brass bristle brush. As needed, remove from grill and wash with warm soapy water.

**Catch pan** - Disposable foil trays are available, or you can line the catch pan with aluminum foil. To clean the catch pan, wash with warm soapy water.

**Inside cooking box** - Brush any debris off of burners tubes. **DO NOT ENLARGE BURNER PORTS (OPENINGS)**. Wash inside of cooking box with warm soapy water.

**Cast Iron Griddle** - See "Maintenance" under "Using the Cast Iron Griddle".

## Storage and/or Nonuse

---

- The gas must be turned off at the LP cylinder when the Weber Gas Barbecue is not in use.
- When the Weber Gas Barbecue is stored indoors, the gas supply must be **DISCONNECTED** and the LP cylinder stored outdoors in a well-ventilated space.
- LP cylinders must be stored outdoors in a well-ventilated area out of reach of children. Disconnected LP cylinders must not be stored in a building, garage or any other enclosed area.
- When the LP cylinder is not disconnected from the Weber Gas Barbecue, the appliance and LP cylinder must be kept outdoors in a well-ventilated space.
- The Weber Gas Barbecue should be checked for gas leaks and any obstructions in the burner tubes before using. (See Sections "General and Annual Maintenance.")
- Check that the areas under the control panel and the bottom tray are free from debris that might obstruct the flow of combustion or ventilation air.

# Refilling the LP tank

We recommend that you refill before the scale indicator reaches "E".

*Note - If you run out of fuel, check the indicator setting and/or adjust the fuel scale indicator setting with the scale setting wing nut, while the tank is empty so you do not run out again.*

## Removal of the LP tank

- 1) Close tank valve (turn clockwise). Figure 4 (a).
- 2) Slide the collar back on the quick disconnect to disengage the fitting. Figure 4 (b).
- 3) Loosen tank lock wing nut and turn tank lock up out of the way.
- 4) Lift tank off.

To refill take LP tank and tank filler adapter to a "Gas Propane" dealer.

**⚠WARNING:** We recommend that your LP tank be filled at an authorized LP gas dealer, by a qualified attendant, who fills the tank by weight. **IMPROPER FILLING IS DANGEROUS.**

**⚠CAUTION:** If you exchange your LP tank, make sure you get a similar tank in return. Your LP tank is equipped with a quick-disconnect valve. Other LP tanks are not compatible with your barbecue connection.

Scale setting wing nut

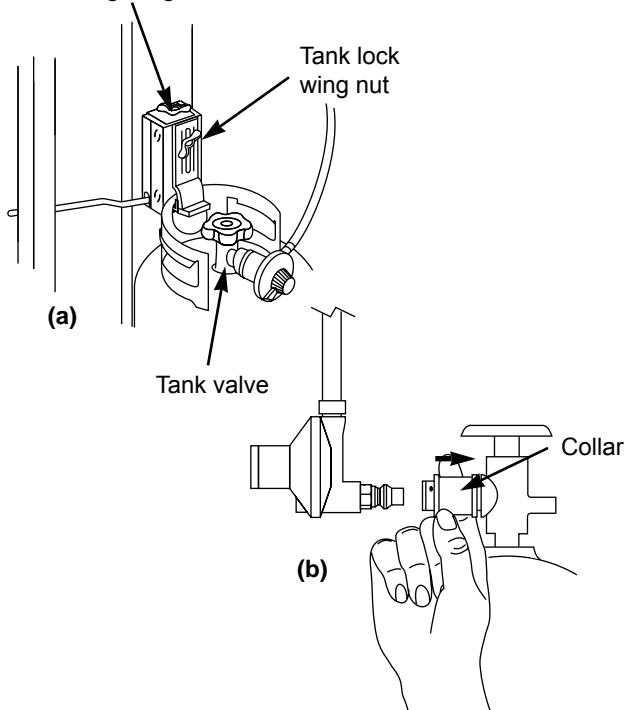

Figure 4

## Connecting the filled LP tank

**⚠WARNING:** Make sure that the LP tank valve is closed. Close by turning clockwise.

### **⚠ DANGER ⚠**

**Do not use an open flame to check for gas leaks. Be sure there are no sparks or open flames in the area while you check for leaks. This will result in a fire or explosion which can cause serious bodily injury or death and damage to property.**

You will need: LP tank, a soap and water solution and a rag or brush to apply it.

*Note - Since some leak test solutions, including soap and water, may be slightly corrosive, all connections should be rinsed with water after checking for leaks*

- a) Lift and hook the tank onto the fuel scale.
- b) Loosen the tank lock wing nut. Swing the tank lock down. Tighten the wing nut. Figure 5.

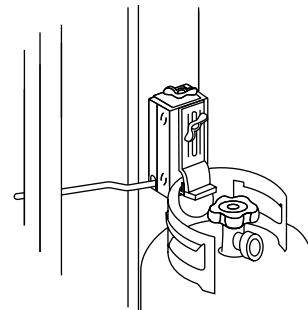
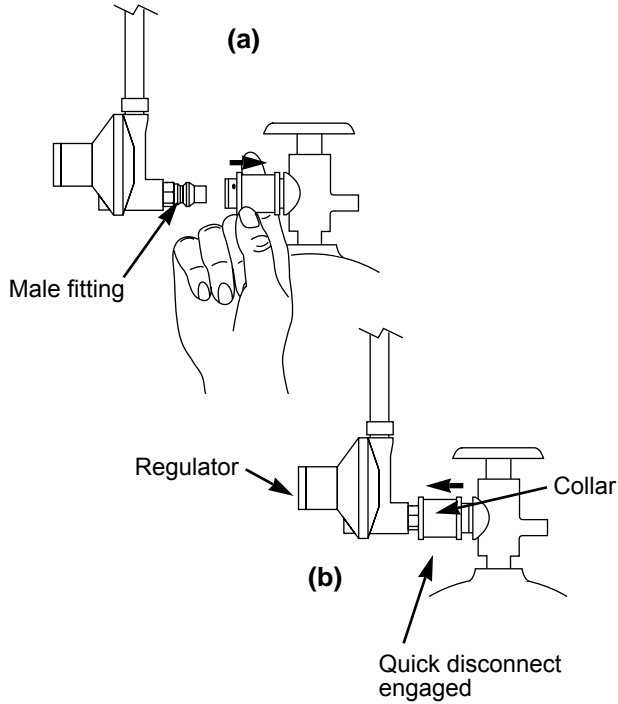

Figure 5

- c) Connect the hose to the tank. Route the hose so it does not interfere with the scale indicator rod. Slide back the collar of the quick disconnect on the tank valve. Figure 6 (a). Push the male fitting of the regulator into the quick disconnect, and maintain pressure. Slide the collar closed. Figure 6 (b). If it does not engage or lock, repeat procedure. Gas will not flow unless the quick disconnect is properly engaged.



**Figure 6**

- d) Mix soap and water.

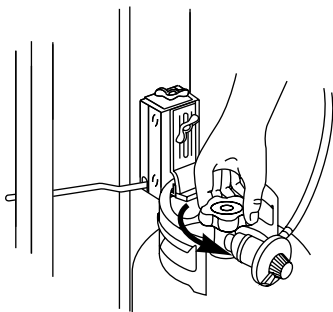

**Figure 7**

- e) Open the tank valve. Figure 7.

- f) Check for leaks by wetting the fitting with the soap and water solution and watching for bubbles. If bubbles form or if a bubble grows there is a leak.

**If leak does not stop, turn off the gas and contact Weber-Stephen Customer Service. Do not use the barbecue.**

- g) When leak checks are complete, turn gas supply OFF and rinse connections with water.

## LP Tank

The LP tank manufacturer is responsible for the materials, workmanship and performance of the tank. If the tank has a defect, malfunctions, or you have a question regarding the tank, call the tank manufacturer's customer service center. The phone number is on the warning decal which is permanently attached to the tank. If the tank manufacturer has not resolved the issue to your satisfaction, then call Weber-Stephen Products Co., Customer Service Center.

## Safe handling tips for LP Gas

- Liquid Propane (LP) gas is a petroleum product as are gasoline and natural gas. LP gas is a gas at regular temperatures and pressures. Under moderate pressure, inside a cylinder, LP gas is a liquid. As the pressure is released the liquid readily vaporizes and becomes gas.
- LP gas has an odor similar to natural gas. You should know this odor.
- LP gas is heavier than air. Leaking LP gas may collect in low areas that prevent dispersion.
- To fill, take the LP tank to an RV center, or look up gas-propane in the phone book for other sources of LP gas, to fill the tank with 20 pounds of liquid propane.

**⚠WARNING:** We recommend that your LP tank be filled at an authorized LP gas dealer, by a qualified attendant, who fills the tank by weight. **IMPROPER FILLING IS DANGEROUS.**

**⚠CAUTION:** If you exchange your LP tank, make sure you get a similar tank in return. Your LP tank is equipped with a quick-disconnect valve. Other LP tanks are not compatible with your barbecue connection.

- Air must be removed from a new LP tank before the initial filling. Your LP dealer is equipped to do this.
- The LP tank must be installed, transported and stored in an upright position. LP tanks should not be dropped or handled roughly.
- Never store or transport the LP tank where temperatures can reach 125° F (too hot to hold by hand - for example: do not leave the LP tank in a car on a hot day).

*Note - A refill will last about 20 hours of cooking time at normal use. The fuel scale will indicate the propane supply so you can refill before running out. You do not have to run out before you refill.*

- Treat "empty" LP tanks with the same care as when full. Even when the LP tank is empty of liquid there still may be gas pressure in the cylinder. **Always close the tank valve before disconnecting.**
- Do not use a damaged LP tank. Dented or rusty LP tanks or LP tanks with a damaged valve may be hazardous and should be replaced with a new one immediately.
- The joint where the hose connects to the LP tank must be leak tested each time the LP tank is reconnected. For example, test each time the LP tank is refilled.
- Be sure the regulator is mounted with the small vent hole pointed downward so it will not collect water. This vent should be free of dirt, grease, bugs etc.

## Liquid Propane (LP) Tank(s)

- The LP tank and connections supplied with your Weber Gas Barbecue have been designed and tested to meet government, American Gas Association and Underwriters Laboratories requirements.
- Replacement LP tanks supplied by Weber satisfy the requirements. Check to be sure the tank has a D.O.T. certification, and has been tested within five years. Your LP gas supplier can do this for you. Figure 8.

**If you have questions about spare LP tanks, please call Weber-Stephen Customer Service.**

### D.O.T. Certification (example)

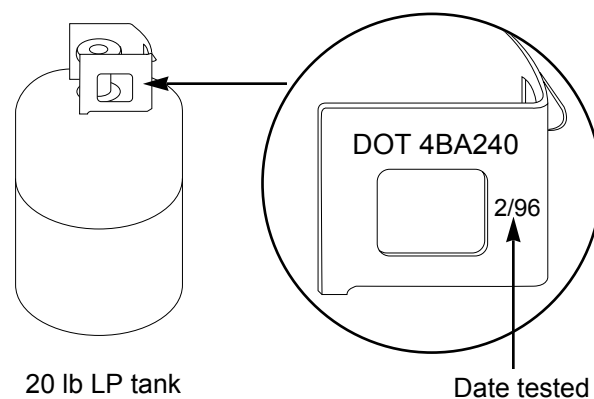

**Figure 8**

- All LP tank supply systems must include a collar to protect the tank valve.
- The LP tank must be a 20 lb size (18 1/4 inches high, 12 1/4 inches in diameter).
- The LP tank must be constructed and marked in accordance with the specifications for LP gas cylinders of the U.S. Department of Transportation (D.O.T.).

# Annual Maintenance

After a period of nonuse we recommend that you perform the following maintenance procedures **for your safety**.

**⚠WARNING:** Check hose before each use of barbecue for nicks, cracking, abrasions or cuts. If the hose is found to be damaged in any way, do not use the barbecue. Replace using only Weber authorized replacement manifold assembly. Contact your dealer.

- Check all gas fittings for leaks.

## ⚠ DANGER ⚠

Do not use an open flame to check for gas leaks. Be sure there are no sparks or open flames in the area while you check for leaks. This will result in a fire or explosion which can cause serious bodily injury or death and damage to property.

## Inspection and Cleaning of the Weber Spider Stopper Guards

To inspect the Spider Stopper Guards, remove the control panel and look to see if they have dust or dirt on their outside surfaces. If they are dirty, brush off the outside surface of the Spider Stopper Guards with a soft bristle brush (an old toothbrush for example). Check that there are no gaps in the Spider Stopper Guards' seams or in the fit around the burners or valves. (See Section "General Maintenance".)

**⚠WARNING:** You should check for gas leaks every time you disconnect and reconnect a gas fitting.

*Note:* All factory made connections have been thoroughly checked for gas leaks. The burners have been flame tested. As a safety precaution you should recheck all fittings for leaks before using your Weber Gas Barbecue. Shipping and handling may have loosened or damaged a gas fitting.

You will need: a soap and water solution and a rag or brush to apply it.

To perform leak checks: Open cylinder valve by turning the cylinder valve handwheel counterclockwise.

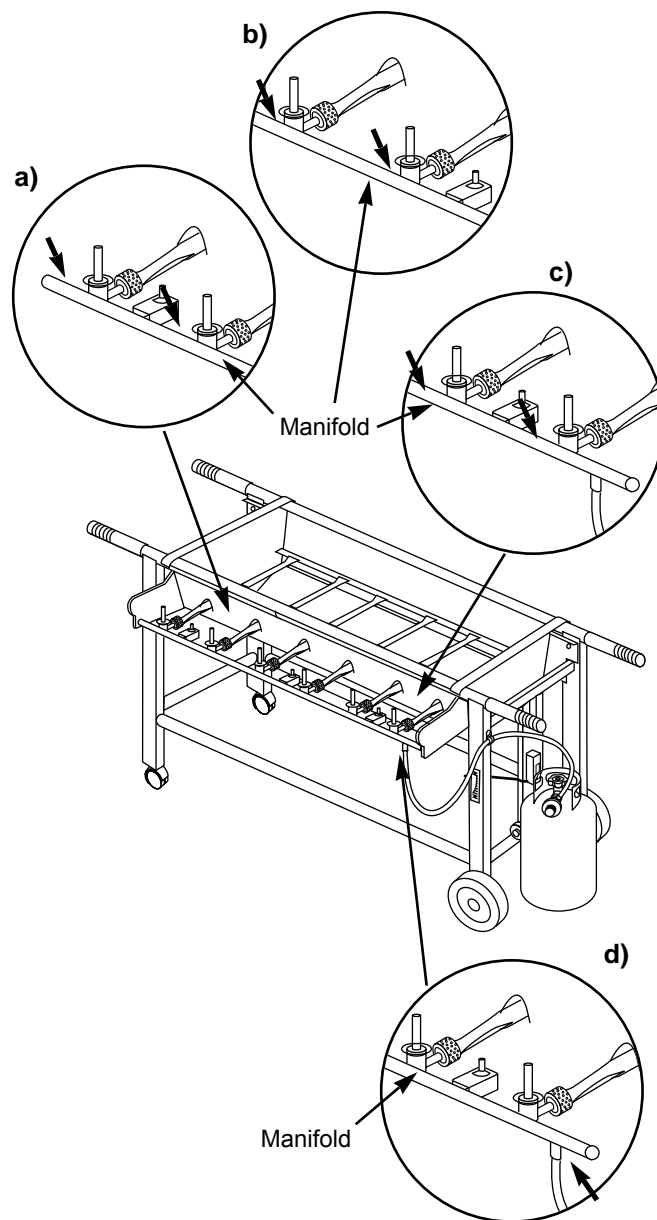

Figure 9

Check for leaks by wetting the connections with the soap and water solution and watching for bubbles. If bubbles form or if a bubble grows there is a leak.

**⚠WARNING: Do not ignite burners while leak checking.**

Check:

- Left valves to manifold connection. Figure 9 (a).
- Center valves to manifold connection. Figure 9 (b).
- Right valves to manifold connection. Figure 9 (c).
- Hose to manifold connection. Figure 9 (d)

**⚠WARNING: If there is a leak at connection 9 (d), turn OFF the gas and retighten the fitting with a spanner and recheck for leaks with soap and water solution.**

**If a leak persists after retightening the fitting, turn OFF the gas. DO NOT OPERATE THE BARBECUE. Contact your dealer.**

- Hose to regulator connection. Figure 10 (a).
- Regulator to cylinder connection. Figure 10 (b).

**⚠WARNING: If there is a leak at connections 9 (a), 9 (b), 9 (c) or 10 (a), turn OFF the gas. Do not operate the barbecue. Contact your dealer.**

**⚠WARNING: If there is a leak at connection 10 (b), retighten and recheck for leaks with soap and water solution.**

When leak checks are complete, turn gas supply OFF at the source and rinse connections with water.

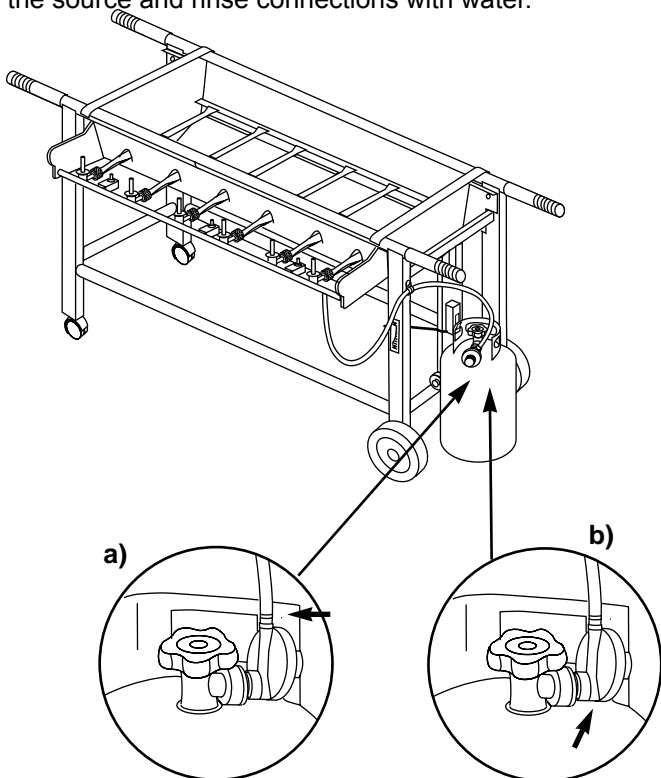

Figure 10

## General Maintenance

### Burner Inspection

Your Weber Gas Barbecue, as well as any outdoor gas appliance, is a target for spiders and other insects. They can nest in the venturi section of the burner tubes. This blocks the normal gas flow, and can cause the gas to flow back out of the air shutter. Figure 11. This could result in a fire in and around the air shutters, under the control panel, causing serious damage to your barbecue.

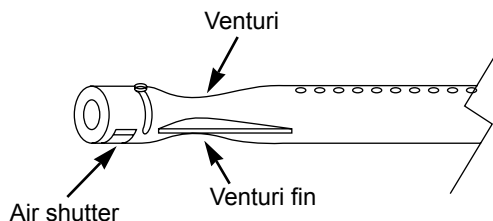

Figure 11

The Weber Spider Stopper Guard is factory installed. It fits tightly around the air shutter section of the burner tube and the valve, thereby preventing spiders and other insects access to the burner tubes through the air shutter openings. Figure 12.

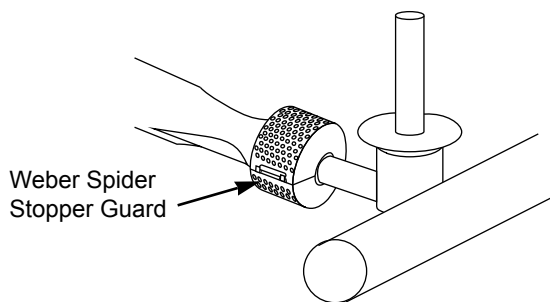

Figure 12

**We recommend that you inspect the Weber Spider Stopper Guards at least once a year. (See Section "Annual Maintenance".) Also inspect and clean the Spider Stopper Guards if any of the following symptoms should ever occur.**

1. The smell of gas in conjunction with the burner flames appearing yellow and lazy.
2. Barbecue does not reach temperature.
3. Barbecue heats unevenly.
4. One or more of the burners do not ignite.

**⚠ DANGER ⚠**

**Failure to correct these symptoms may result in a fire which can cause serious bodily injury or death and cause damage to property.**

## Main Burner Flame Pattern

The Weber Gas Barbecue burners have been factory set for the correct air and gas mixture. The correct flame pattern is shown in Figure 13.

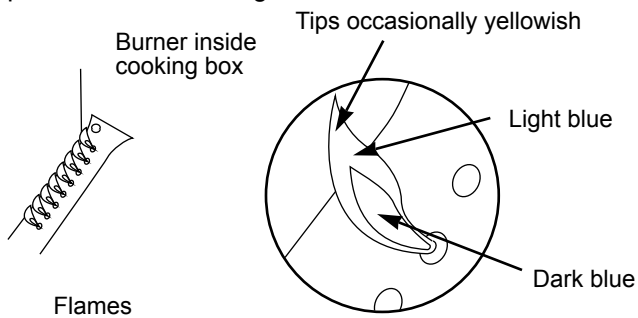

Figure 13

If the flames do not appear to be uniform the length of the burner tube, follow the burner cleaning procedures.

## Main Burner Cleaning Procedure

**Turn off the gas supply.** Remove the manifold. (See Section "Replacing the main burners".)

Look inside each burner with a flashlight. Figure 14.

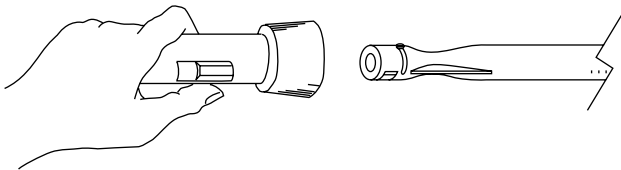

Figure 14

Clean the inside of the burners with a wire (a straightened out coat hanger will work). Figure 15. Check and clean the air shutter opening at the ends of the burners. Check and clean the valve orifices at the base of the valves. Use a brass bristle brush to clean outside of burners. This is to make sure all the burner ports are fully open.

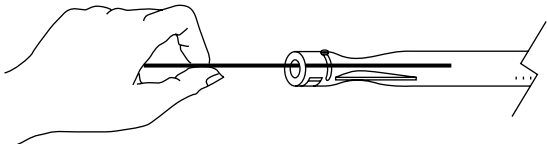

Figure 15

**⚠CAUTION:** Do not enlarge the burner ports when cleaning.

## Replacing the Burners

1. Your Weber Gas Barbecue must be OFF and cool.
2. Turn OFF gas at source.
3. Disconnect regulator.
4. To remove control panel refer to Step "Remove the control panel and the front panel".
5. Remove splash guards.
6. Remove cooking grill(s) and griddle.
7. Remove Flavorizer bars.
8. Remove the manifold by unsnapping the clips at the right and left front of the cooking box. Figure 16.

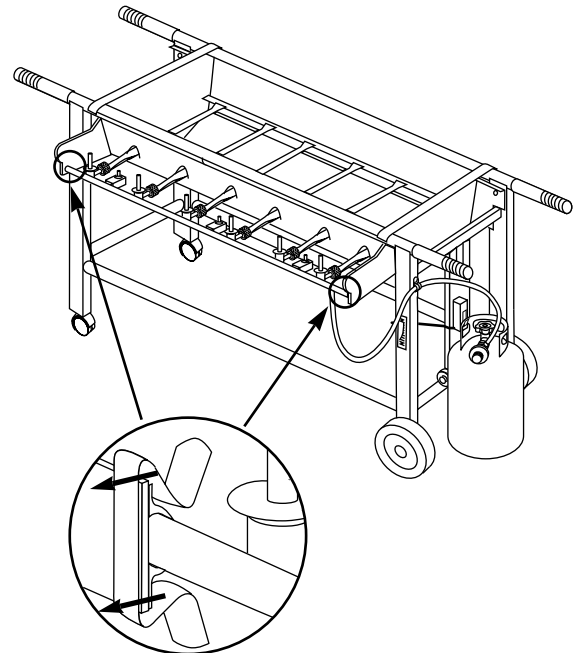

Figure 16

9. Disconnect white and black wire from each igniter. Figure 17.

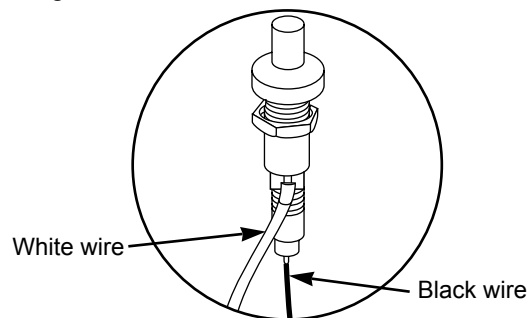
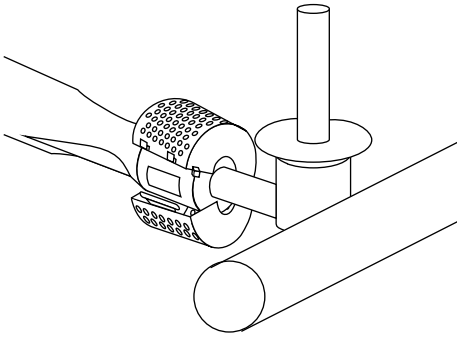

Figure 17

10. Unlatch the Spider Stopper Guards and remove.  
Figure 18.



**Figure 18**

11. Pull the manifold out of the burners. Figure 19.

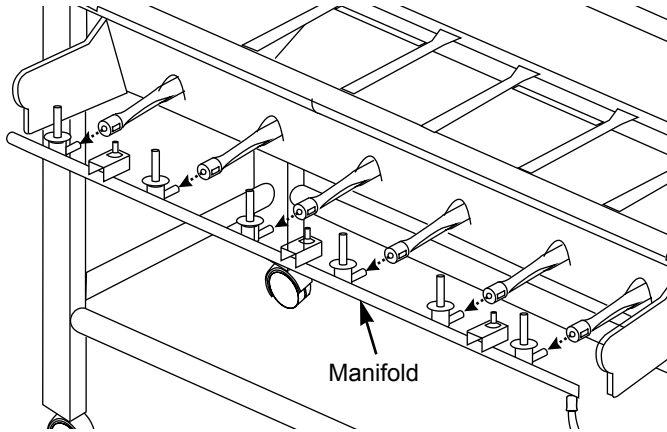

**Figure 19**

12. Slide the burner assembly from each Heat Zone.  
The left and right burners are connected by the  
Crossover tube. Figure 20(a).

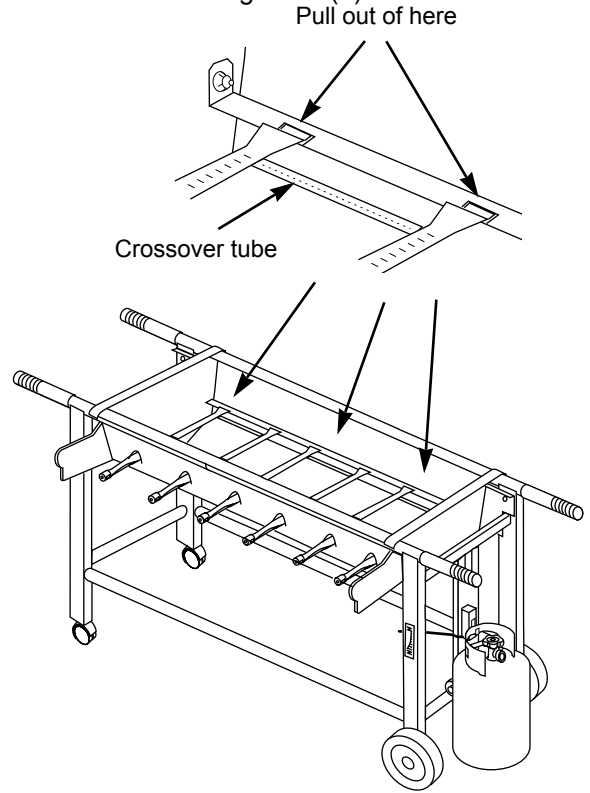

**Figure 20**

13. Lift and twist the burner assembly slightly to separate the crossover tube from the burners. Remove the burners from the cooking box. Figure 21.

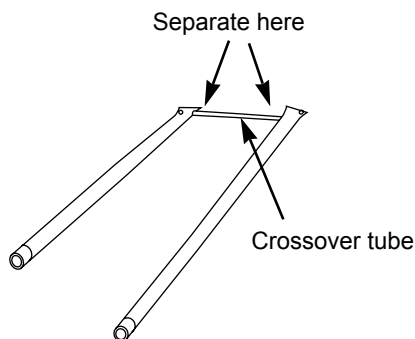
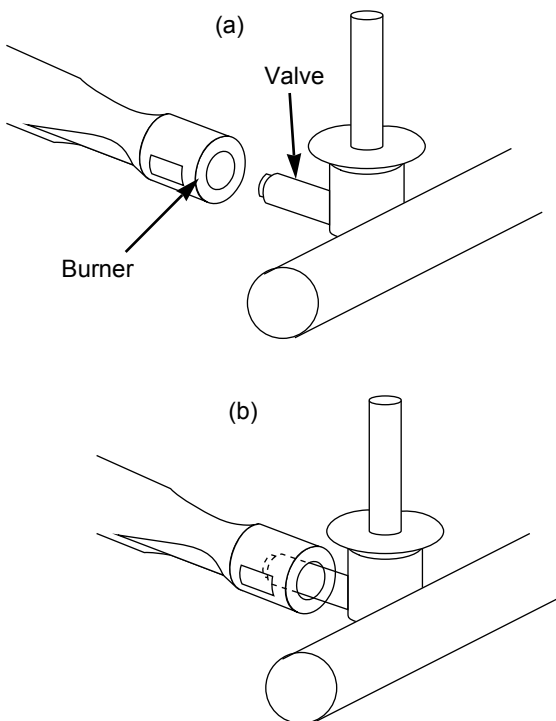

**Figure 21**

14. To reinstall the burners, reverse steps 3 through 13.

**⚠CAUTION:** The burner openings must be positioned properly over the valve orifices. Figure 22a.

Check proper assembly before fastening manifold in place. Figure 22b.



**Figure 22**

15. Reinstall the Spider Stopper Guards. Slightly rotate the Spider Stopper Guards so that the seams are in line with the Venturi fins. There should be no gaps in the seams or in the fit around the burners and valves. Figure 23.

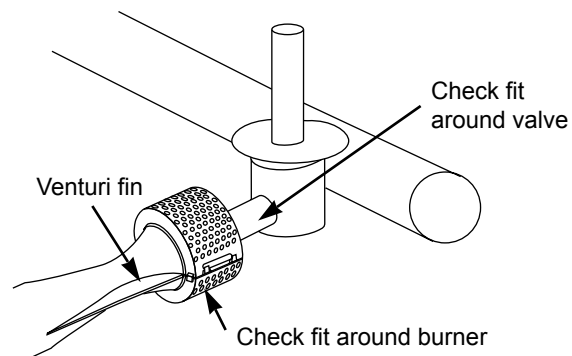

**Figure 23**

**⚠CAUTION:** If the Spider Stopper Guards do not fit tightly, contact Weber-Stephen Customer Service.

**⚠CAUTION:** After reinstalling the gas lines, they should be leak checked with a soap and water solution before using the barbecue. See Step "Check for gas leaks".

### Crossover Ignition System Operations

If the Crossover Ignition System fails to ignite the Front burner, light the Front burner with a match. If the Front burner lights with a match, then check the Crossover Ignition System.

- Check that both the white and black ignition wires are attached properly. Figure 24.

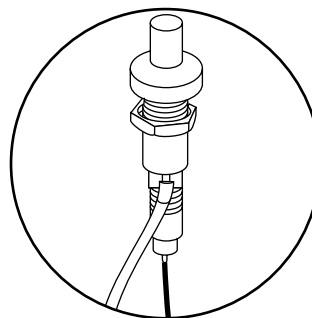

**Figure 24**

- Check that the Crossover Ignition button pushes the igniter (button) down, and returns to the up position.
- Check to see if the igniter is loose in the frame. Tighten if necessary; see Step "Install igniter" for correct procedure.

If the Crossover Ignition System still fails to light, contact your dealer.

# TROUBLESHOOTING

Problem	Check	Cure
Burners burn with a yellow or orange flame, in conjunction with the smell of gas.	Inspect Weber Spider Stopper Guards for possible obstructions. (Blockage of holes.)	Clean Weber Spider Stopper Guards. (See Section "Annual Maintenance".)
Burners do not light. -or- Burners have a small flickering flame in the HIGH position. -or- Barbecue temperature only reaches 250° to 300° degrees in the HIGH position.	The excess flow safety device, which is part of the barbecue to tank connection, may have activated.	To reset the excess flow safety device turn all burner control knobs and the tank valve OFF. Disconnect the regulator from the tank. Turn burner control knobs to HIGH. Wait at least 1 minute. Turn burner control knobs OFF. Reconnect the regulator to the tank. Turn tank valve on slowly. Refer to "Lighting Instructions".
Burner does not light, or flame is low in HIGH position.	Is LP fuel low or empty?	Refill LP tank.
	Is fuel hose bent or kinked?	Straighten fuel hose.
	Does the Front burner light with a match?	If you can light the Front burner with a match, then check the Crossover Ignition System.
Experiencing flare-ups:	Are you preheating barbecue in the prescribed manner?	All burners on high for 10 to 15 minutes for preheating.
	Are the cooking grates and Flavorizer Bars heavily coated with burned-on grease?	Clean thoroughly. (See Section "Periodic Cleaning".)
	Is the bottom tray "dirty" and not allowing grease to flow into catch pan?	Clean bottom tray.
<b>CAUTION: Do not line the bottom tray with aluminum foil.</b>		
Burner flame pattern is erratic. Flame is low when burner is on HIGH. Flames do not run the whole length of the burner tube.	Are burners clean?	Clean burners. (See Section "General Maintenance".)
Fuel scale shows that there is gas in the LP tank, but tank is empty.	Check adjustment of fuel scale.	Fuel scale must be adjusted with an empty tank.
Barbecue seems to lose heat when cooking in cold weather temperatures 50° F or colder. <i>(The liquid propane in the cylinder turns to vapor too slowly to supply the burners with gas. This is due to the air temperature cooling the LP cylinder which slows the vaporization process.)</i>	Is there frost/ice on the outside of the LP cylinder?	Turn off burner control knobs and the LP cylinder. Replace with a spare LP cylinder and resume cooking. <b>⚠WARNING: The spare or disconnected LP cylinder must be stored outdoors in a well ventilated area out of the reach of children. The spare or disconnected LP cylinder must never be stored under or near your Weber Gas Barbecue.</b>

If problems cannot be corrected by using these methods, please contact Weber-Stephen Customer Service.



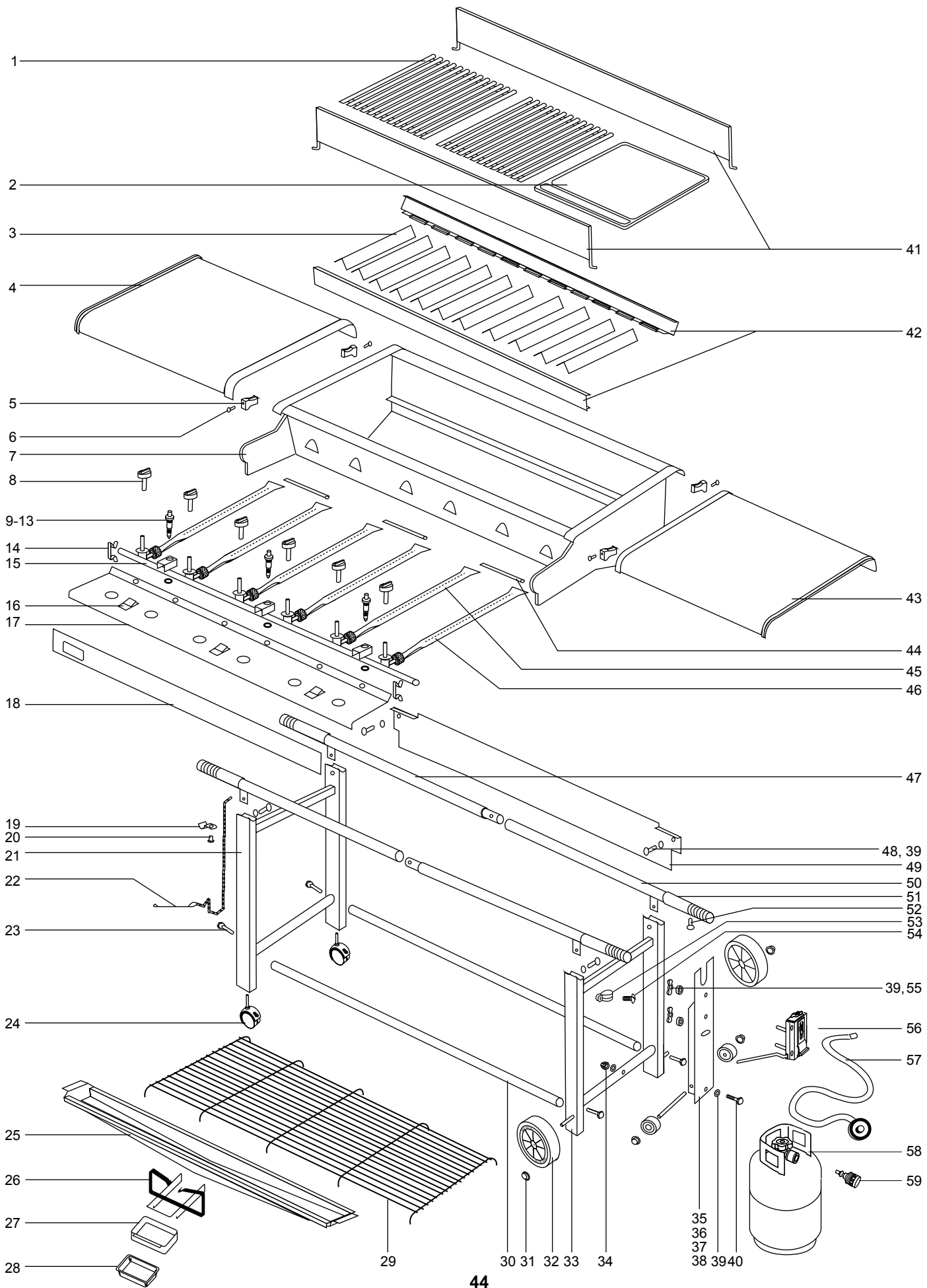

# Parts List

---

All items are single quantities unless otherwise specified.

Parts can be ordered directly from Weber-Stephen Products Company by phone or mail.

*Note - Do not return parts to Weber-Stephen Products Co. without first contacting the Customer Service Center by phone or mail. Returning the part may not be necessary.*

- 1 Cooking grills (2)
- 2 Griddle
- 3 Flavorizer bars (11)
- 4 Left work surface
- 5 Glides (4)
- 6 Phillips head 1/4-20 x 1 inch machine screws (4)
- 7 Cooking box (assembly)
- 8 Burner control knobs (6)
- 9 Igniter (3)
- 10 Igniter lock nut (3)
- 11 Igniter wire (black) (3)
- 12 Igniter wire (white) (3)
- 13 Gas catcher ignition chamber (3)
- 14 Manifold mounting clips (2)
- 15 Manifold assembly
- 16 Igniter buttons (3)
- 17 Control panel
- 18 Front panel
- 19 Match holder bracket
- 20 Plastic button
- 21 Caster frame
- 22 Match holder
- 23 1/4-20 x 3 1/2 inch bolt (4)
- 24 Caster (2)
- 25 Bottom tray
- 26 Catch pan holder
- 27 Catch pan
- 28 Drip pans (2)
- 29 Accessory rack
- 30 Bottom connectors (2)

While we give much attention to our products, unfortunately an occasional error may occur. If a part is missing, do not go back to the store. Call the Weber Customer Service Center toll free **1-800-446-1071** to receive immediate assistance. Have your owner's manual and serial number of the barbecue available for reference.

**Weber-Stephen Products Company  
Customer Service Center  
250 South Hicks Road  
Palatine, IL 60067-6241  
(847) 705-8660  
(800) 446-1071**

- 31 Wheel hub caps (2)
- 32 Wheels (2)
- 33 Wheel frame
- 34 1/4-20 hex nut
- 35 Cylinder glides (2)
- 36 Glide axle
- 37 Glide hubcaps (2)
- 38 Cylinder panel
- 39 1/4 inch nylon washers (12)
- 40 1/4-20 x 1 3/4 inch bolt
- 41 Splash guards (2)
- 42 Flavorizer bar / Cooking grill holders (2)
- 43 Right work surface
- 44 Crossover tubes (3)
- 45 Left burner (3)
- 46 Right burner (3)
- 47 Top frame rail #1 (2)
- 48 1/4-20 x 1/2 inch bolts (6)
- 49 Back panel
- 50 Top frame rail #2 (2)
- 51 Plastic handle (4)
- 52 #8-16 x 1 inch screw (8)
- 53 Hose Clamp
- 54 1/4-20 x 5/8 screw
- 55 1/4-20 wing nuts
- 56 Fuel scale assembly
- 57 Hose / Regulator
- 58 LP tank
- 59 Filler adapter

## **⚠ WARNING:**

**Use only Weber factory authorized parts. The use of any part that is not factory authorized can be dangerous. This will also void your warranty.**





# A FINAL WORD OF THANKS

**T**hank you for choosing a Weber Barbecue. Our family here at Weber has worked hard to produce the highest quality products for your satisfaction.

While we give much attention to our products, an occasional error may occur. Our knowledgeable Customer Service staff is prepared to help you with any problems with parts or assembly.

Call our toll free number 1-800-446-1071.

For quicker service, please have your owner's manual available for reference. We also welcome any comments or suggestions you might have regarding our products.

We wish your family the best in outdoor cooking enjoyment.

Weber-Stephen Products Company  
Customer Service Center  
200 East Daniels Road  
Palatine, Illinois 60067-6266