

GENESIS®

Silver C

Gas Grill

Owners Guide

⚠ DANGER

If you smell gas:

1. Shut off gas to the appliance.
 2. Extinguish any open flames.
 3. Open lid
 4. If odor continues, keep away from the appliance and immediately call your gas supplier or your fire department.
- Leaking gas may cause a fire or explosion which can cause serious bodily injury or death, or damage to property.

⚠ WARNING

Do not store or use gasoline or other flammable liquids or vapors within 25 feet (8m) of this appliance.

⚠ WARNING: Follow all leak-check procedures carefully in this manual prior to barbecue operation. Do this even if the barbecue was dealer-assembled.

NOTICE TO INSTALLER: These instructions must be left with the owner and the owner should keep them for future use.

THIS GAS APPLIANCE IS DESIGNED FOR OUTDOOR USE ONLY.

⚠ WARNING: Do not try to light this appliance without reading the "Lighting" Instructions section of this manual



Natural Gas



YOU MUST READ THIS OWNERS GUIDE BEFORE OPERATING YOUR GAS GRILL

A042.e
B006.e
C096.b
D006.e



55146 03/28/01

⚠ DANGER

Failure to follow the Dangers, Warnings and Cautions contained in this Owner's Manual may result in serious bodily injury or death, or in a fire or an explosion causing damage to property.

⚠ WARNINGS

- ⚠ Do not store a spare or disconnected liquid propane cylinder under or near this barbecue.**
- ⚠ Improper assembly may be dangerous. Please carefully follow the assembly instructions in this manual.**
- ⚠ After a period of storage, and/or nonuse, the Weber Gas Barbecue should be checked for gas leaks and burner obstructions before use. See instructions in this manual for correct procedures.**
- ⚠ Do not operate the Weber gas barbecue if there is a gas leak present.**
- ⚠ Do not use a flame to check for gas leaks.**
- ⚠ Combustible materials should never be within 24 inches of the top, bottom, back or sides of your Weber gas barbecue.**
- ⚠ Do not put a barbecue cover or anything flammable on, or in the storage area under the barbecue.**
- ⚠ Your Weber Gas Barbecue should never be used by children. Accessible parts of the barbecue may be very hot. Keep young children away while it is in use.**
- ⚠ You should exercise reasonable care when operating your Weber gas barbecue. It will be hot during cooking or cleaning and should never be left unattended, or moved while in operation.**
- ⚠ Should the burners go out while in operation, turn all gas valves off. Open the lid and wait five minutes before attempting to relight, using the lighting instructions.**
- ⚠ Do not use charcoal or lava rock in your Weber gas barbecue.**
- ⚠ Never lean over open grill or place hands or fingers on the front edge of the cooking box.**
- ⚠ Should a grease fire occur, turn off all burners and leave lid closed until fire is out.**
- ⚠ Do not enlarge valve orifices or burner ports when cleaning the valves or burners.**
- ⚠ The Weber Gas Barbecue should be thoroughly cleaned on a regular basis.**
- ⚠ Liquid propane gas is not natural gas. The conversion or attempted use of natural gas in a liquid propane unit or liquid propane gas in a natural gas unit is dangerous and will void your warranty.**
- ⚠ Do not attempt to disconnect any gas fitting while your barbecue is in operation.**
- ⚠ Use heat-resistant barbecue mitts or gloves when operating barbecue.**
- ⚠ Combustion byproducts produced when using this product contain chemicals known to the state of California to cause cancer, birth defects, or other reproductive harm.**

LIQUID PROPANE GAS UNITS ONLY:

- ⚠ Use the regulator that is supplied with your Weber Gas Barbecue.**
- ⚠ Do not attempt to disconnect the gas regulator or any gas fitting while your barbecue is in operation.**
- ⚠ A dented or rusty liquid propane cylinder may be hazardous and should be checked by your liquid propane supplier. Do not use a liquid propane cylinder with a damaged valve.**
- ⚠ Although your liquid propane cylinder may appear to be empty, gas may still be present, and the cylinder should be transported and stored accordingly.**
- ⚠ If you see, smell or hear the hiss of escaping gas from the liquid propane cylinder:**

- 1. Move away from liquid propane cylinder.**
- 2. Do not attempt to correct the problem yourself.**
- 3. Call your fire department.**

Warranty

Weber-Stephen Products Co. (Weber) hereby warrants to the ORIGINAL PURCHASER of this Weber Gas Grill that it will be free of defects in material and workmanship from the date of purchase as follows:

Aluminum Castings	lifetime
1 year paint	
Porcelain Hood Section	25 years
Burners	10 years
Igniter	3 years
Cooking Grates	5 years against manufacturer defects
Flavorizer Bars	1 year no rust through Thermoplastic/ Thermoset Parts
10 years	Excluding fading
All Remaining Parts	5 years

when assembled and operated in accordance with the printed instructions accompanying it.

Weber may require reasonable proof of your date of purchase. THEREFORE, YOU SHOULD RETAIN YOUR SALES SLIP OR INVOICE.

This Limited Warranty shall be limited to the repair or replacement of parts that prove defective under normal use and service and which on examination shall indicate, to Weber's satisfaction, they are defective.

Before returning any parts, contact the Customer service representative in your region using the contact information sheet provided with your manual. If Weber confirms the defect and approves the claim, Weber will elect to replace such parts without charge. If you are required to return defective parts, transportation charges must be prepaid. Weber will return parts to the purchaser, freight or postage prepaid.

This Limited Warranty does not cover any failures or operating difficulties due to accident, abuse, misuse, alteration, misapplication, vandalism, improper installation or improper maintenance or service, or failure to perform normal and routine maintenance, including but not limited to damage caused by insects within the burner tubes, as set out in this owner's manual.

Deterioration or damage due to severe weather conditions such as hail, hurricanes, earthquakes or tornadoes, discoloration due to exposure to chemicals either directly or in the atmosphere, is not covered by this Limited Warranty.

There are no other express warrants except as set forth herein and any applicable implied warranties of merchantability and fitness are limited in duration to the period of coverage of this express written Limited Warranty. Some regions do not allow limitation on how long an implied warranty lasts, so this limitation may not apply to you.

Weber is not liable for any special, indirect or consequential damages. Some regions do not allow the exclusion or limitation of incidental or consequential damages, so this limitation or exclusion may not apply to you.

Weber does not authorize any person or company to assume for it any other obligation or liability in connection with the sale, installation, use, removal, return, or replacement of its equipment; and no such representations are binding on Weber.

This Warranty applies only to products sold at retail.

WEBER-STEPHEN PRODUCTS CO.
Customer Service Center
1890 Roselle Road, Suite 308
Schaumburg, IL 60195
USA

Contents

Danger & Warnings	A-2
Warranty	A-3
General Instructions	A-5
Exploded View	A-6
Parts List	A-9
Assembly Instructions	B-1
Installing Features	C-1
Cast Iron Cooking Grates Care	C-D
Operating	D-1
Lighting	D-1
Manual Lighting	D-2
Lighting the side Burner	D-3
Cooking	D-4
Storage and/or Nonuse	D-4
Cleaning	D-4
Annual Maintenance	D-5
General Maintenance	D-6
Replacing Main Burners	D-7
Crossover Ignition System Operations ...	D-8
Troubleshooting	D-9
Side Burner Troubleshooting	D-10

General Instructions

Your Weber Gas Barbecue is a portable outdoor cooking appliance. With the Weber Gas Barbecue you can grill, barbecue, roast and bake with results that are difficult to duplicate with indoor kitchen appliances. The closed lid and Flavorizer® Bars produce that “outdoor” flavor in the food.

The Weber Gas Barbecue is portable so you can easily change its location in your yard or on your patio. Portability means you can take your Weber Gas Barbecue with you if you move.

The natural gas supply is easy to use and gives you more cooking control than charcoal fuel.

- These instructions will give you the minimum requirements for assembling your Weber Gas Barbecue. Please read the instructions carefully before using your Weber Gas Barbecue. Improper assembly can be dangerous.
- Not for use by children.
- If there are local codes that apply to portable gas grills, you will have to conform to them. If there are no local codes, you must conform to the latest edition of the National Fuel Gas Code: ANSI Z 223.1.
- This Weber Gas Barbecue is designed for natural (piped in city) gas only. Do not use liquid propane (LP) bottled gas. The valves, orifices and hose are for natural gas only.
- Do not use with charcoal fuel.
- Check that the area under the control panel and the bottom tray are free from debris that might obstruct the flow of combustion or ventilation air.

For Installation in Canada

These instructions, while generally acceptable, do not necessarily comply with the Canadian Installation codes, particularly with piping above and below ground. In Canada the installation of this appliance must comply with local codes and/or Standards CAN/CGA-B149.1 (Installation Code for Natural Gas Burning Appliances and Equipment).

Storage

- The gas must be turned OFF at the natural gas supply when the Weber Gas Barbecue is not in use.
- When the Weber Gas Barbecue is stored indoors, the gas supply must be disconnected.

Operating

⚠ WARNING: Only use this barbecue outdoors in a well-ventilated area. Do not use in a garage, building, breezeway or any other enclosed area.

⚠ WARNING: Never use your Weber Gas Barbecue under an unprotected combustible roof or overhang.

⚠ WARNING: Your Weber Gas Barbecue is not intended to be installed in or on recreational vehicles and/or boats.

⚠ WARNING: Do not use combustible materials within 24 inches of the top, bottom, back or sides of the grill.

⚠ WARNING: The entire cooking box gets hot when in use. Do not leave unattended.

⚠ WARNING: Keep any electrical supply cord and the fuel supply hose away from any heated surface.

⚠ WARNING: Keep the cooking area clear of flammable vapors and liquids, such as gasoline, alcohol, etc., and combustible materials.

Gas Supply Testing

- Disconnect your Weber Gas Barbecue when the gas supply is being tested at high pressures. This appliance and its individual shutoff valve must be disconnected from the gas supply piping system during any pressure testing of that system at test pressures in excess of 1/2 psig (3.5 kPa).
- Turn OFF your Weber Gas Barbecue when the gas supply is being tested at low pressures. This appliance must be isolated from the gas supply piping system by closing its individual manual shutoff valve during any pressure testing of the gas supply piping system at the pressure equal to or less than 1/2 psig (3.5 kPa).

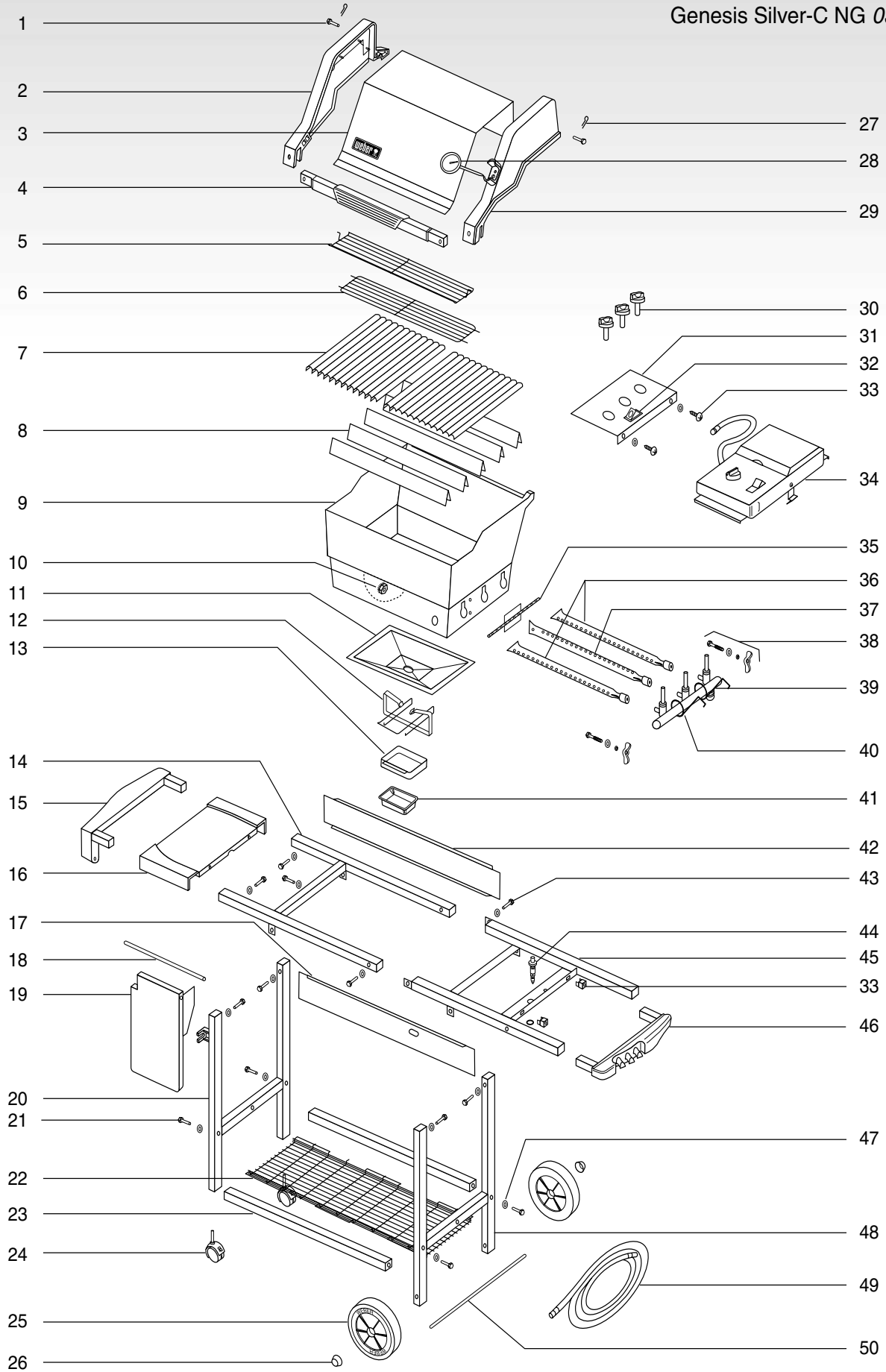



1. Hinge Pin
2. Left Endcap
3. Shroud
4. Handle
5. Warm-Up™ Basket
6. Warming Rack
7. Cooking Grates
8. Flavorizer Bars
9. Cooking Box
10. 1/4-20 keps nut
11. Slide Out Bottom Tray
12. Catch pan holder
13. Catch pan
14. Left Frame
15. Left Trim Piece
16. Work Surface
17. Front Panel
18. Hinge Rod
19. Swing-Up Work Surface
20. Caster Frame
21. 1/4-20 x 2 inch bolts
22. Bottom Shelf
23. Frame Connectors
24. Casters
25. Wheels
26. Hubcap
27. Hair Pin Cotter
28. Thermometer
29. Right Endcap
30. Burner Control Knobs
31. Control Panel
32. Ignitor Button
33. Control Panel Hardware
34. Side Burner
35. Crossover tube
36. Front and Back Burners
37. Center Burner
38. Manifold Hardware
39. Manifold
40. Manifold Support Bracket.
41. Disposable Drip Pan
42. Back Panel
43. 1/4-20 x 1/2 inch bolts
44. Igniter
45. Right Frame
46. Right Trim Piece
47. Nylon Washer
48. Wheel Frame
49. Hose
50. Axle

© 2001 Weber-Stephen Products Co., Weber, the  silhouette, and the kettle configuration are registered trademarks of Weber-Stephen Products Co., 200 East Daniels Road, Palatine, IL, 60067-6266, U.S.A. This product is covered by one or more United States patents and patents in other nations globally. Printed in the U.S.A.

Screwdriver 

Phillips screwdriver 

Hammer 

7/16 open-end or an adjustable wrench 

Pliers 

Block of wood 

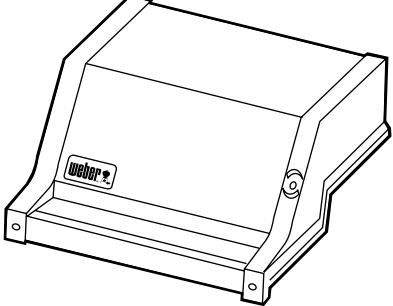
Lid - 1 

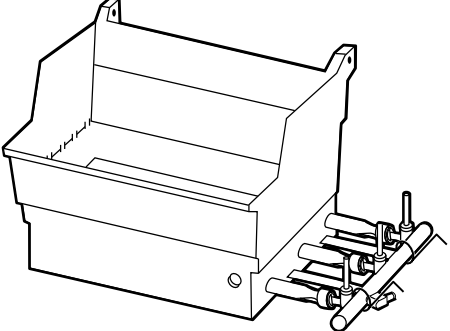
Cooking Box - 1 

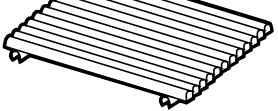
Cooking grates - 2 

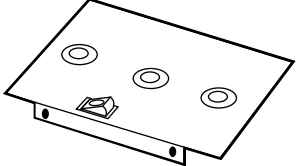
Control panel - 1 

Left Frame - 1 

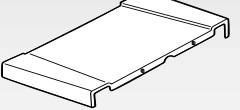
Right Frame - 1 

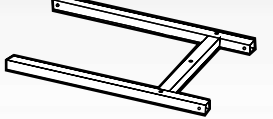
Wheel Frame - 1 

Caster Frame - 1 

Frame Connectors - 2 

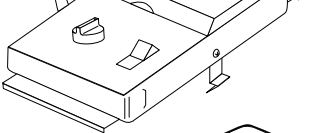
Side Burner - 1 

Left Trim Piece - 1 

Right Trim Piece - 1 

Work Surface - 1 

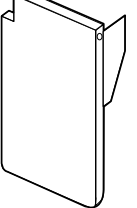
Swing-Up Work Surface - 1 

Hinge Rod - 1 

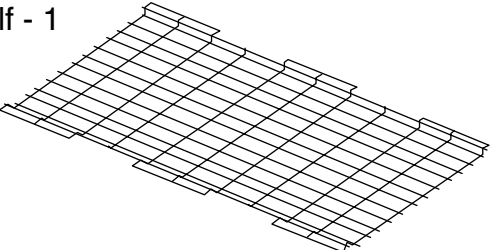
Bottom Shelf - 1 

Warming Rack - 1

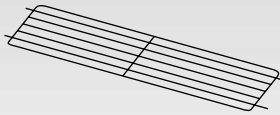

Warm-Up Basket - 1

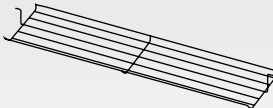

Flavorizer Bars - 5



Front Panel - 1

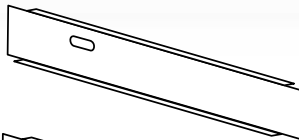

Back Panel - 1

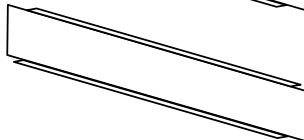

Bottom tray - 1

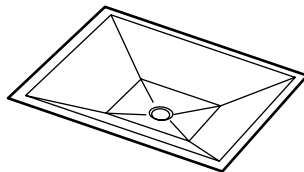

Catch Pan Holder - 1



Catch-Pan - 1



Disposable Drip Pans - 2



Thermometer - 1



Wheels - 2



Casters - 2



Burner Control Knobs - 3

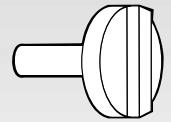

Hinge Pins (1/4 x 1 1/2 inch clevis pin) - 2

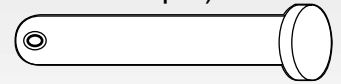

2 inch bolts (1/4 x 20 x 2 inch bolts) - 5

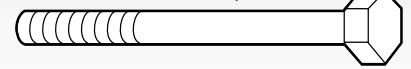

1/2 inch bolts (1/4 x 20 x 1/2 inch bolts) - 8

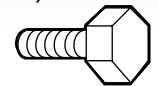

Keps Nut (1/4 x 20 Keps Nut) - 1

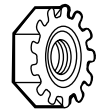

Nylon Washers - 13

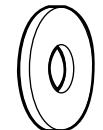

Cotter Pin - 2



Hubcaps - 3



Control Panel Hardware (Phillips screws/washers) - 2

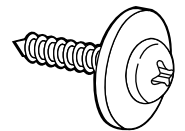

Hose - 1

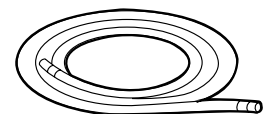

Axel Rod - 1

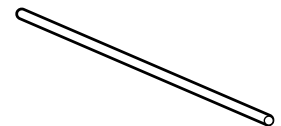

Assembly Instructions

Assemble wheel frame

You will need: axle rod, two wheel hubcaps, two wheels, wheel frame, hammer and a block of wood. Place one end of the axle rod on the block of wood (or other protected surface). Tap one hubcap onto the end of the axle rod. Slide one wheel onto the axle, WEBER name facing out. Next, slide the other end of the axle rod through the wheel frame. Add the other wheel, WEBER name side facing out. Tap the hubcap onto the axle rod to complete the axle.

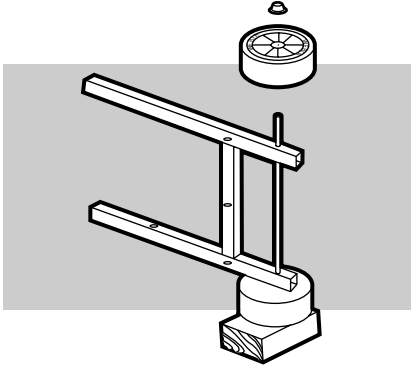

Assemble frame

You will need: left frame, right frame, two 1/2 inch bolts, two nylon washers and a 7/16 inch or adjustable wrench.

Note - Work on carpeted area (on grass or one of the boxes) to protect the finish during frame assembly. Lay the leg frame pieces as shown so the leg tabs point up.

- 1) Connect the two frame pieces with the tabs inside of the frame.
- 2) Slip washers on bolts, then insert bolts as shown and tighten. (If you try to insert a bolt and there is no hole, you have the left frame turned the wrong way. Turn the left frame around.)

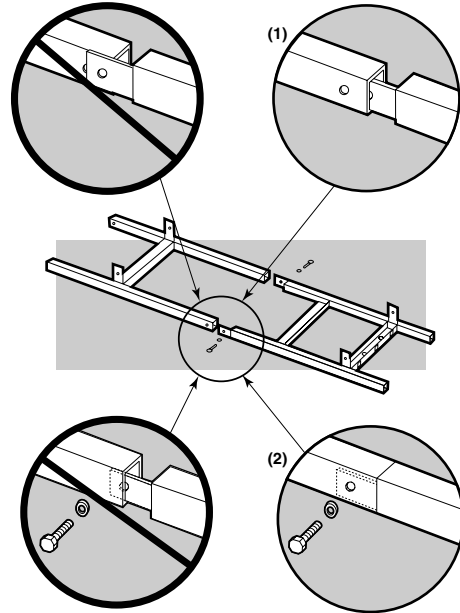

Continue frame assembly

You will need: caster frame and wheel frame.

Place the caster frame onto the tabs of the left frame, so that the swing table locking bracket (1) is to the rear. Place the wheel frame onto the tabs of the right frame, so that the swing table locking bracket is to the rear (2). The leg tabs must be on the inside of the frames.

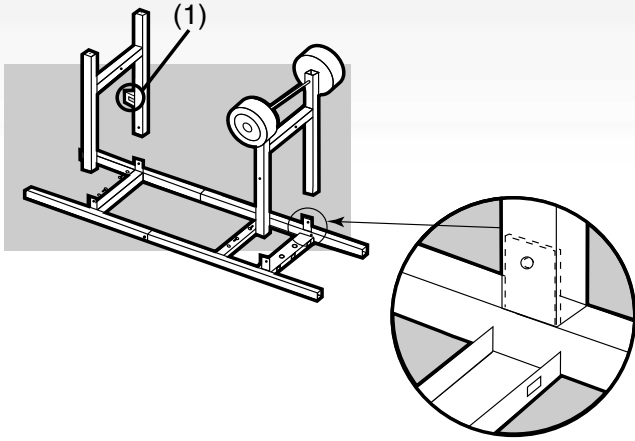

Add front panel

You will need: frame assembly, front panel, two 1/2 inch bolts, two nylon washers, and a 7/16 or adjustable spanner.

Place the front panel with the matchlight hole(1) down and to your right against the inside frame assembly as shown in illustration.

Add washer to bolt. Insert bolt through the front panel and into the frame. Insert bolt on other end through the front panel and the frame. Tighten bolts.

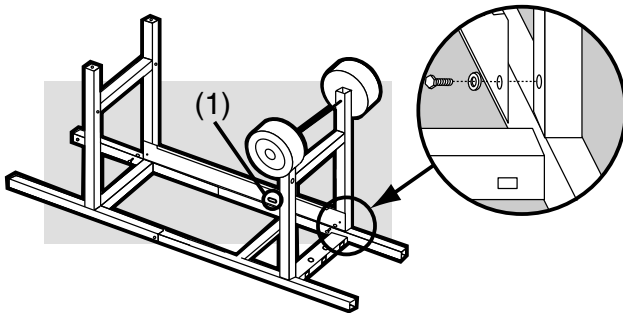

Add back panel

You will need: frame assembly, back panel, two 1/2 inch bolts, two nylon washers, and a 7/16 or adjustable spanner.

Place the back panel against the inside frame assembly as shown in illustration.

Add washer to bolt. Insert bolt through the back panel and into the frame. Insert bolt on other end through the back panel and the frame. Tighten bolts.

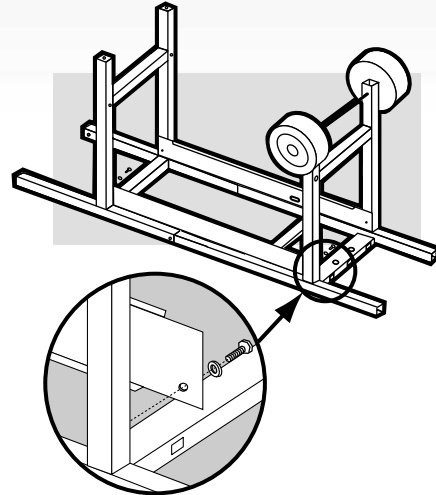

Complete frame assembly

You will need: partial frame assembly, two frame connectors, four 2 inch bolts, four nylon washers and a 7/16 inch or adjustable wrench.

Hold one frame connector between the caster frame and wheel frame. Add the nylon washer to the bolt. Insert the bolt through the frame and screw into frame connector. Tighten bolt with wrench. Repeat procedure with the other frame connector.

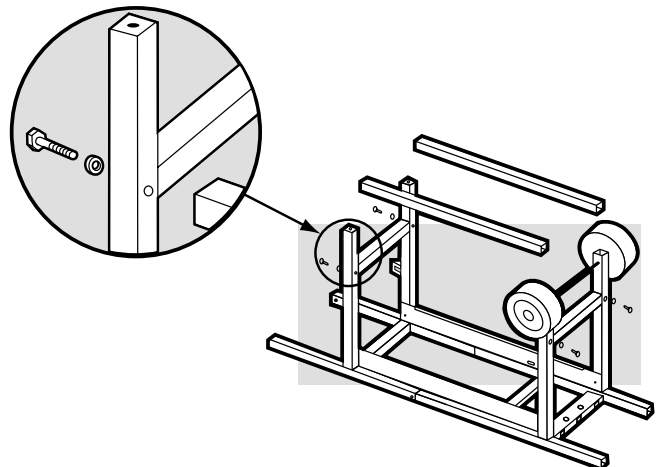

Insert casters

You will need: frame assembly and two casters.
Push the casters firmly into the inserts in the ends of the caster frame.

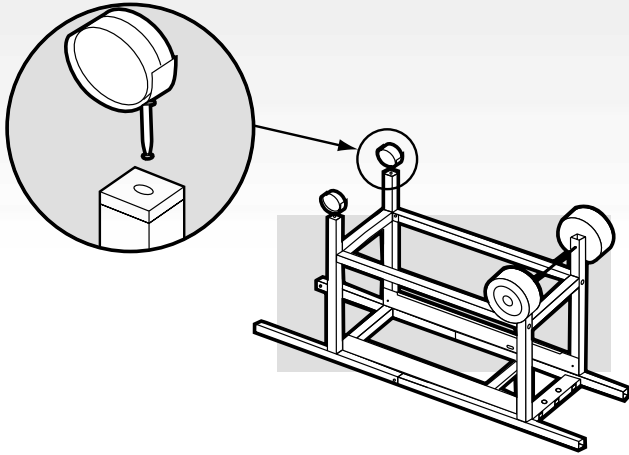

Slide the cooking box (assembly) to the left within the frame assembly. Add the nylon washer to the bolt. Insert the bolt through the cooking box and frame with the head of the bolt outside the box. Add the keps nut. Tighten by holding the bolt with pliers while you tighten the nut with a wrench.

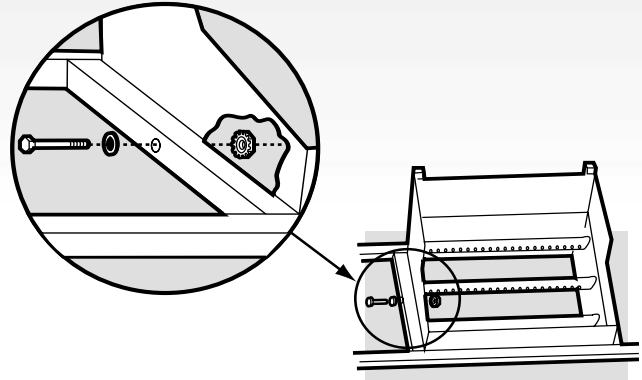

Add cooking box (assembly)

You will need: frame assembly, cooking box (assembly), 2 inch bolt, nylon washer, keps nut, pliers and a 7/16 inch or adjustable wrench.

Place the cooking box (assembly) in the frame assembly so the burner tubes(1) are under the frame brace(2).

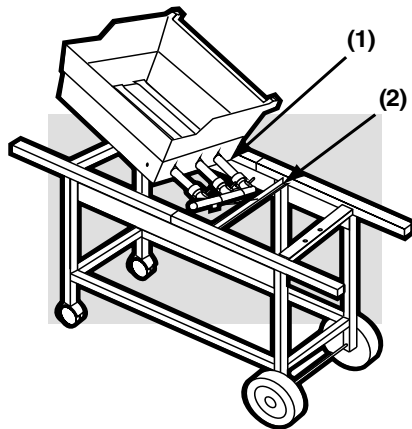

Your Weber Gas Grill Manifold assembly consisting of gas manifold, valves and gas burners has been factory assembled, pressure- and flame- tested. As a safety precaution, we recommend you check the burner alignment:

- 1) Are the ends of the burners under the washers at the left rear and left front of the cooking box? The screws are only guides. Do not tighten.
- 2) Do the valves fit into the ends of the burners?
- 3) Are the wing nuts under the burner assembly hand tight? Do not tighten with pliers.

If you answered YES to 1, 2 and 3, the burners are correctly aligned. If you answered NO, the burners are misaligned. Contact the Customer Service Representative in your region using the contact information sheet provided with your manual. Do not use grill.

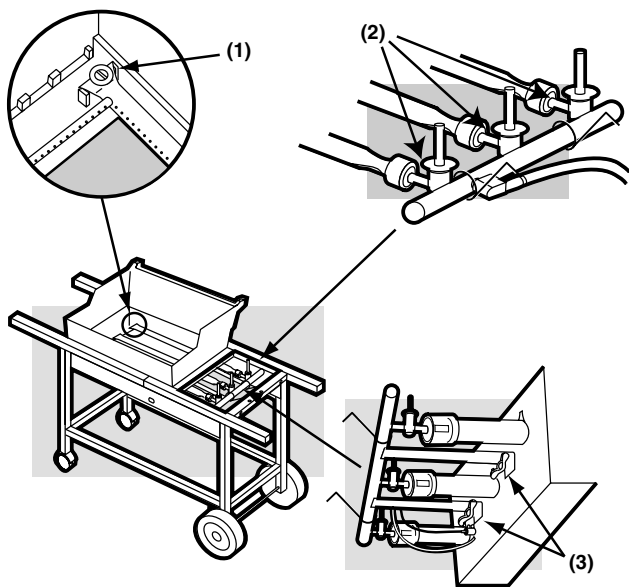

Install manifold brackets

The manifold brackets(2) are already in place on the manifold between the valves.

Place your hand underneath the manifold. Lift the manifold and cooking box slightly and hook the manifold bracket(2) onto the frame brace(1).

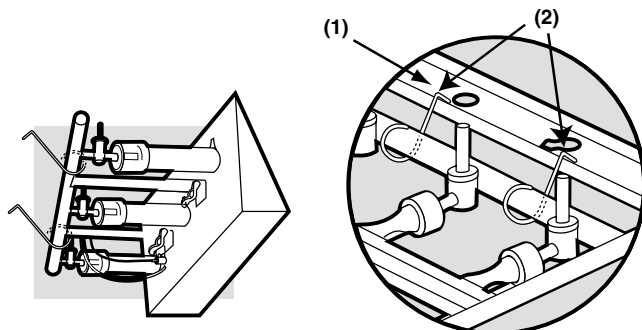

Install Gas Supply

General Specifications for Piping

Note - Contact your local municipality for building codes regulating outdoor gas barbecue installations. In absence of Local Codes, you must confirm to the latest edition of ANSI Z223.1. WE RECOMMEND THAT THIS INSTALLATION BE DONE BY A PROFESSIONAL.

Some of the following are general requirements taken from ANISI Z223.1 latest edition for complete specifications.

- This barbecue is designed to operate at 7 inches of water column pressure (.2526 psi).
 - A manual shut-off valve must be installed outdoors, immediately ahead of the quick disconnect.
 - An additional manual shut-off valve indoors should be installed in the branch fuel line in an accessible location near the supply line
 - The quick disconnect connects to a 3/8 inch NPT thread from the gas source. The quick disconnect fitting is a hand-operated device that automatically shuts OFF the flow of gas from the source when the barbecue is disconnected
 - The quick disconnect fitting can be installed horizontally, or pointing downward. Installing the fitting with the open end pointing upward can result in collecting water and debris.
 - The dust covers (supplied plastic plugs) help keep the open ends of the quick disconnect fitting clean while disconnected.
 - Pipe compound should be used which is resistant to the action of natural gas when connections are made.
 - The outdoor connector must be firmly attached to rigid, permanent construction.
- ⚠ WARNING: Do not route the 12 foot hose under a deck. The hose must be visible.**

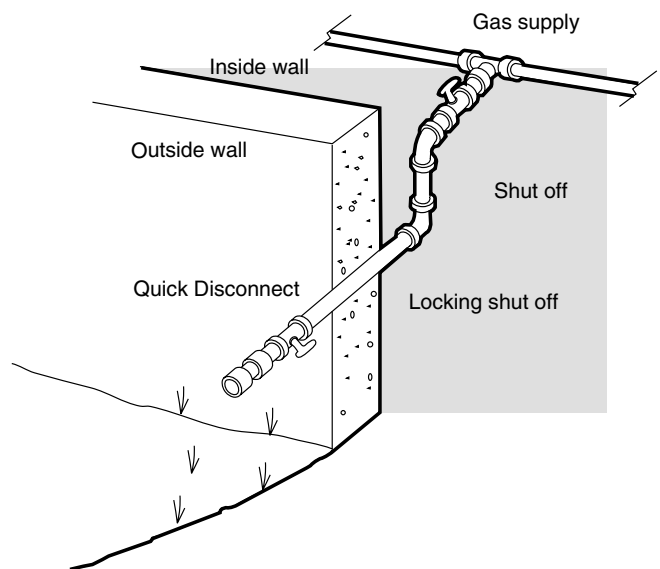

Gas Line Piping

■ If the length of the line required does not exceed 50 feet, use a 5/8" O.D. tube. One size larger should be used for lengths greater than 50 feet.

■ Gas piping may be copper tubing, type K or L; polyethylene plastic tube, with a minimum wall thickness of .062 inch; or standard weight (schedule 40) steel or wrought iron pipe.

■ Copper tubing must be tin-lined if the gas contains more than 0.3 grams of hydrogen sulfide per 100 cubic feet of gas.

■ Plastic tubing is suitable only for outdoor, underground use.

■ Gas piping in contact with earth, or any other material which may corrode the piping, must be protected against corrosion in an approved manner.

■ Underground piping must have a minimum of 18" cover

Test Connections

All connections and joints must be thoroughly tested for leaks in accordance with local codes and all listed procedures in the latest edition of ANSI Z223.1

⚠ DANGER

Do not use an open flame to check for gas leaks. Be sure there are no sparks or open flames in the area while you check for gas leaks. This will result in a fire or explosion which can cause serious bodily injury or death and damage to property.

Install igniter

Note - The igniter wires are already attached to the Gas Catcher Ignition Chamber and the igniter. This was done to factory test the ignition system.

The igniter lock nut is on the igniter.

- 1) Loosen the igniter lock nut.
- 2) Insert the top of the igniter up through the large part of the keyhole in the frame brace. Slide the igniter into the small part of the keyhole.
- 3) Tighten the igniter lock nut back onto the igniter.

Note - If the igniter works loose, carefully tighten the igniter lock nut with an adjustable wrench or pliers.

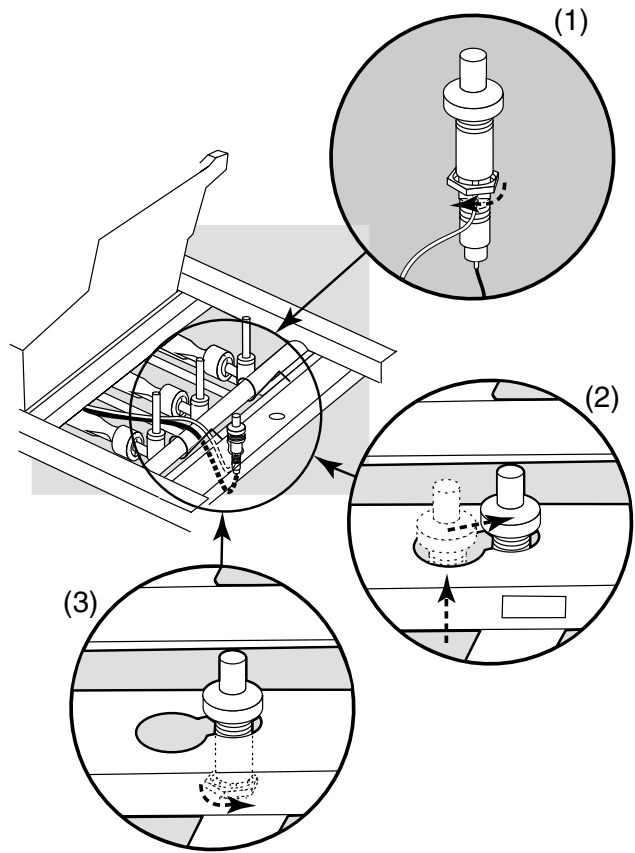

Check that all burner valves are off

You will need: burner control knobs.

Valves are shipped in the OFF position, but you should check to be sure that they are turned OFF. Put the knob on each valve. Check by pushing down and turning clockwise. If they do not turn, they are off. Proceed to the next step. If they do turn continue turning them clockwise until they stop, then they are off. Proceed to the next step.

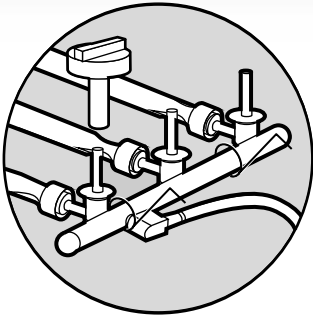

Connect flexible hose to manifold

You will need: the 12 foot natural supply hose and a 3/4 inch wrench.

Thread fitting end of hose onto manifold. Tighten with wrench.

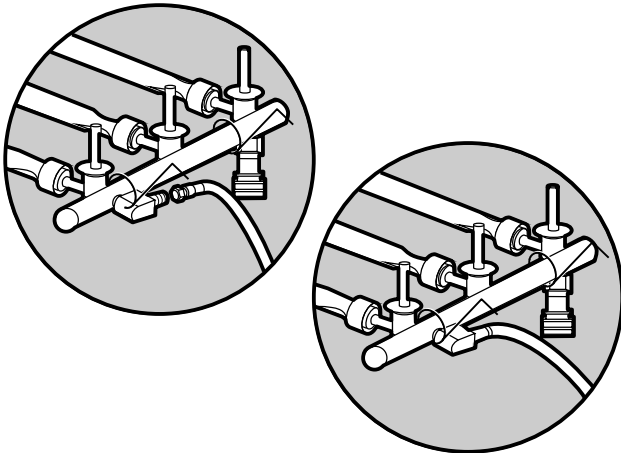

Install the slide out bottom tray

You will need: the slide out bottom tray(1), catch pan holder(2), catch pan and one disposable drip pan.

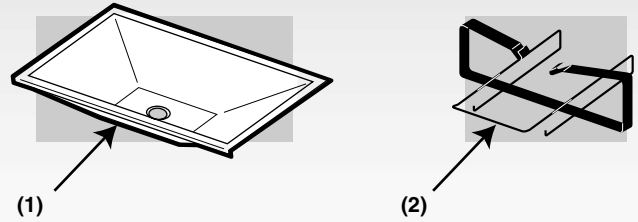

Hook the ends of the catch pan holder into the hole in the slide out bottom tray. **The front of the catch pan holder must be on the same side as the finger grip(1) of the bottom tray.**

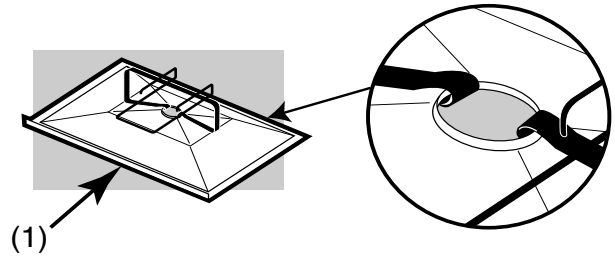

Slide the bottom tray onto the mounting rails under the cooking box with finger grip toward you(1).

⚠ WARNING: Do not line bottom tray with aluminum foil. It can cause grease fires by trapping the grease and not allowing grease to flow into the catch pan.

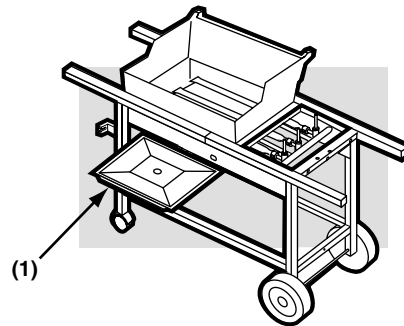

Put the disposable drip pan into the catch pan.

Slide the catch pan into the catch pan holder with its finger grip towards you(1).

Install Lid

You will need: lid, two hair pin cotters(1) and two hinge pins(2).

Place lid on top of the cooking box. Align the hinges at the rear of the barbecue. Insert hinge pins through the hinges from the outside. Insert hair pin cotters into the small holes in the hinge pins.

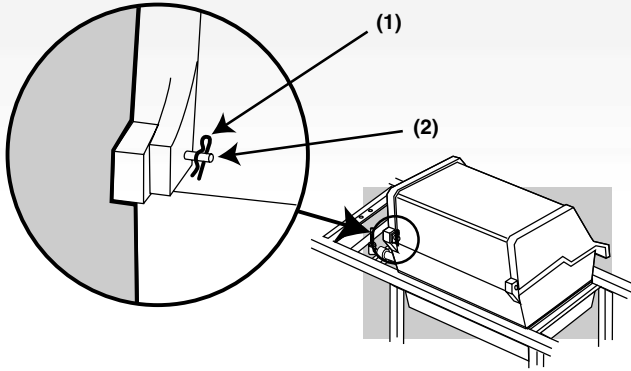

Install control panel and burner control knobs

You will need: control panel, two Phillips screws/washers, a Phillips screwdriver, and burner control knobs.

- 1) Set the control panel in place over both frame braces. Hold the Crossover Ignition button up while setting the control panel in place.
- 2) Line up the holes in the control panel with the holes in the white plastic plugs in the frame brace. Insert screws and tighten with a Phillips screwdriver until snug. Do not overtighten.
- 3) Push each of the burner control knobs onto their valve.

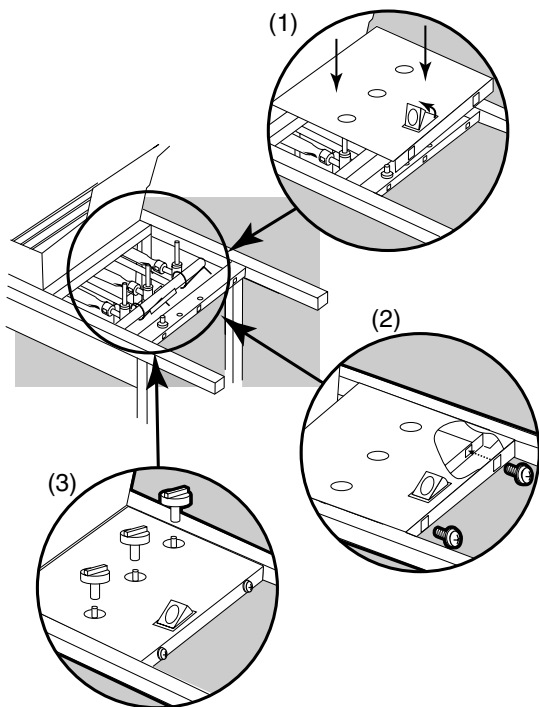

Cast Iron Cooking Grates Care

Instructions

⚠WARNING: Follow all safety instructions provided with your barbecue. Do not drop cast iron grates, they will break.

First Time Use - Wash thoroughly with a mild dishwashing liquid to remove the wax coating used for protection in shipping. Rinse with warm water and dry completely with a soft cloth or paper towel. NEVER ALLOW TO DRAIN DRY, OR WASH IN A DISHWASHER. You must season the grates before first use to prevent rust and keep foods from sticking.

Seasoning Cast Iron Grates - A SOLID vegetable shortening is recommended for the initial seasoning. Spread a thin coating of solid vegetable shortening over entire surface of the cast iron grates with a paper towel. Be certain the entire surface, including all corners, has been coated thoroughly. (Do not use salted fat such as margarine or butter.)

Turn burners to MOM (MM if you have a two burner Silver A model) with lid closed. Preheat grill for 10 minutes. Place cast iron grate back in grill. Allow grill to heat for 1 to 1 1/2 hours. Turn all burners to OFF. Leave cooking grates in barbecue until they are cool. Your cast iron cooking grates are now ready to use.

Maintenance - Brush debris off with a steel bristled wire brush.

Reseasoning - After each use the grates may be reseasoned by coating with a solid vegetable shortening, closing the lid and leaving the cast iron grates in grill until it is cool.

Tips - The cast iron grates will turn black with use. The pores of the iron will be sealed, providing a durable coating that helps to prevent foods from sticking. The grates will further season with use. REGULAR APPLICATIONS OF SOLID VEGETABLE SHORTENING WILL IMPROVE ITS RESISTANCE TO RUST.

Rust, a metallic taste or discolored foods are signs of improper or inadequate seasoning or may result from cooking acidic foods. If this occurs, wash thoroughly and reseason.

Since cast iron holds heat well, you will not need to use extremely high cooking temperatures. Best results are obtained with medium to medium-high heat. Do not overheat.

As with all cast iron, the more the use, the easier the maintenance.

Note: Prior to storing, grease very lightly with solid vegetable shortening, then wipe dry with a paper towel. Store in a dry place.

Installing Features

Install the right trim piece with tool holders

You will need: Right trim piece with tool holders

Push the Right trim piece into the frame as shown(1), making sure that the tabs on the underside of the trim piece are snapped into the slots in the frame.(2)

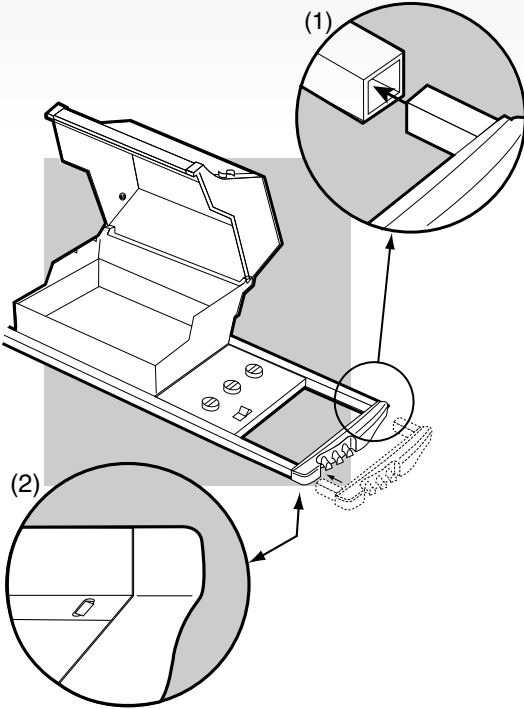

Install the left end trim piece and swing-up work surface

You will need: End trim piece, swing-up work surface, swing-up work surface rod, two 1/2 inch bolts, two nylon washers and a wrench

1.) Start the left end trim piece into the frame as shown, **do not push the trim piece in all of the way and do not add bolts yet.**

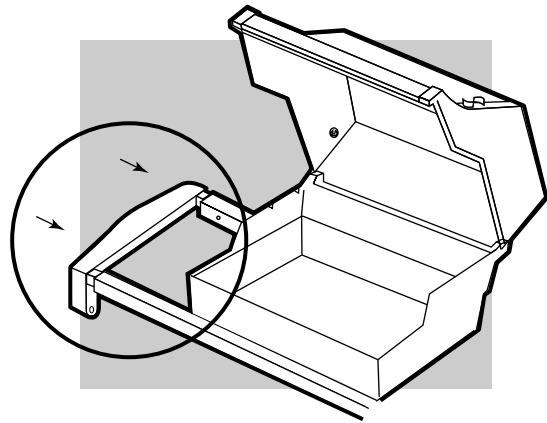

2.) Slide the swing-up work surface rod through the holes at the top of the swing-up work surface.

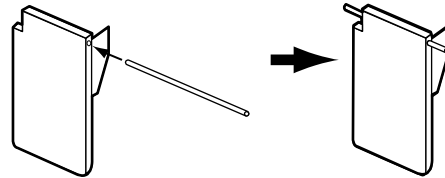

- 3.) Insert one end of the swing-up work surface rod into the hole in the frame.

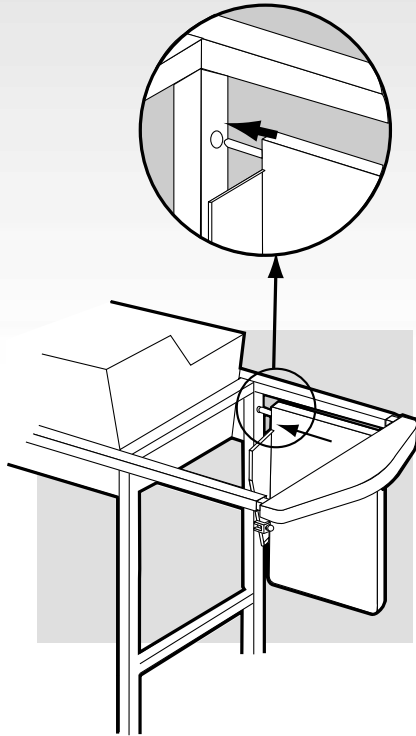

- 4.) While holding swing-up work surface in position, insert the other end of the swing-up work surface rod into the left end trim piece. Push the trim piece into the frame.

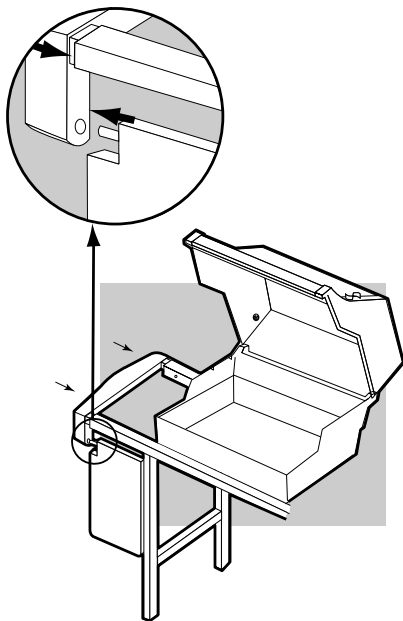

- 5.) Add a washer to each bolt and insert it through the hole in the frame and the hole in the trim piece on both sides. Tighten with a wrench.

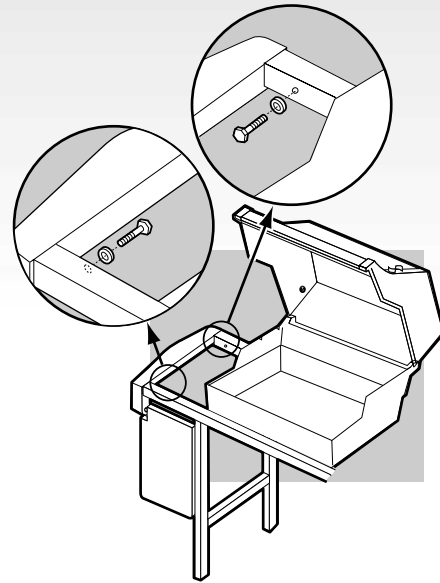

To raise swing-up work surface: Lift table all the way up and slide it to the right, then lower table until you feel it lock in the up position.

To lower swing-up work surface: Lift table up until it disengages and slide it to the left. Then lower it all the way down so that the locking pin on the right side of the table fits into the locking bracket on the leg, which will secure the table in the down position.

Do not use the work surface as a cutting board.

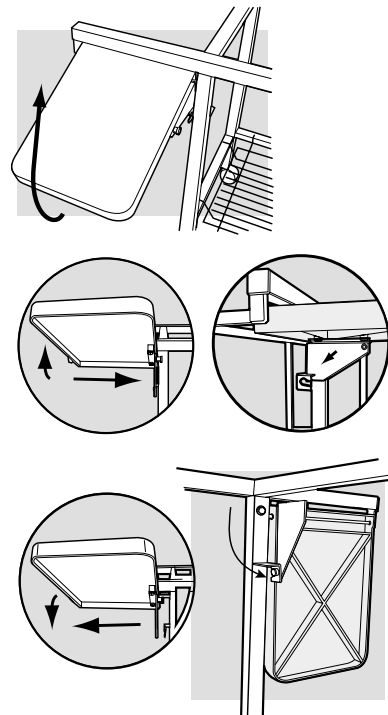

Install the work surface

You will need: work surface.

Place the work surface, so that the front and back edges fit over the frame, in the area between the left trim piece and the cooking box as shown.

Do not use the work surface as a cutting board.

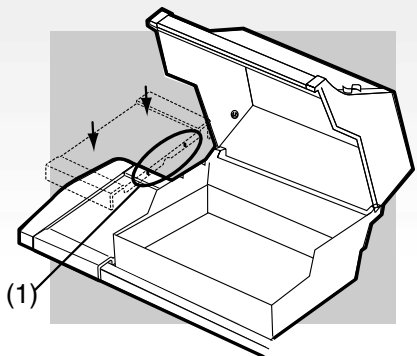

(1) Make sure that the tabs on the side table are to the right, next to the cooking box.

Install side burner

You will need: side burner,

⚠ WARNING: Make sure gas supply is off.

Start the side burner hose into the opening between the control panel and right trim piece route the hose between the cylinder panel and wheel frame.

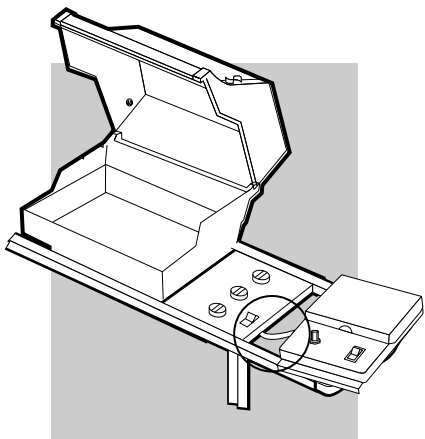

Set the side burner in place in the frame. The side burner locking clip on the right should latch under the right trim piece.

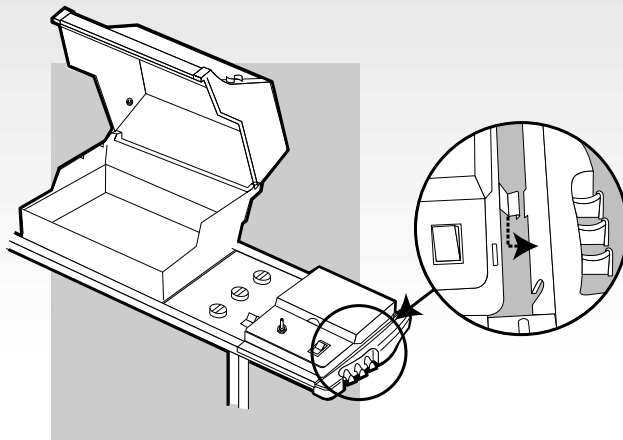

Tilt the side burner slightly, toward the control panel. Latch the side burner locking clip on the left, under the control panel.

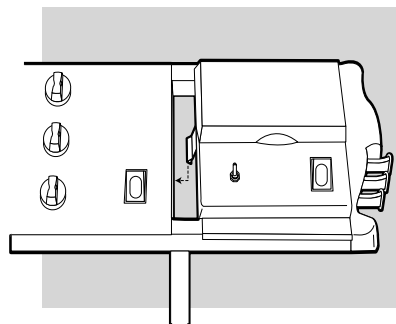

Push side burner control knob onto the valve

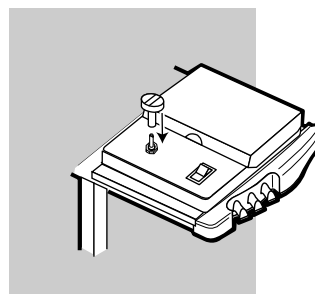

Connect the side burner hose as follows:

- 1) Slide back the collar of the quick disconnect on the manifold.
- 2) Push the male fitting of the side burner hose into the quick disconnect, and maintain pressure. Slide the collar closed.

Quick disconnect will be engaged.

Check to be sure that the side burner valve is OFF.

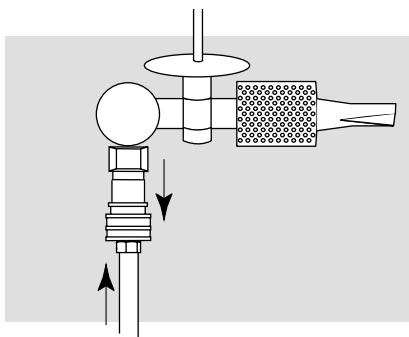
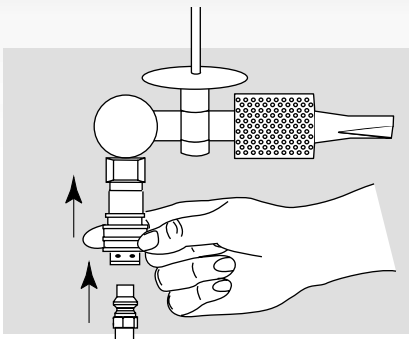

Install Flavorizer® Bars and Cooking Grates

You will need: five Flavorizer Bars and two cooking grates.

Place the Flavorizer Bars side by side in the cooking box.

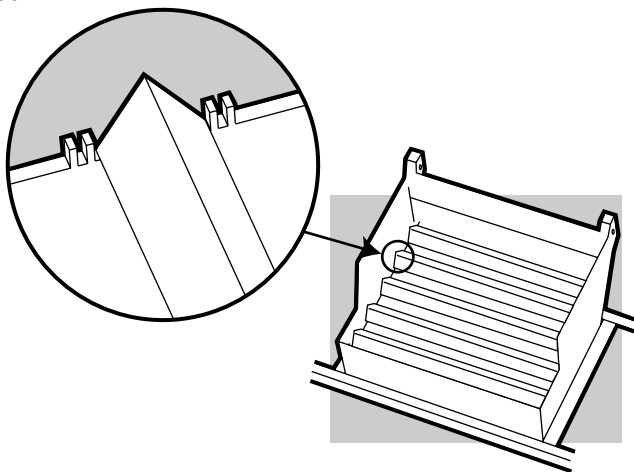

Set the cooking grates onto the ledges in the cooking box with the rounded sides up.

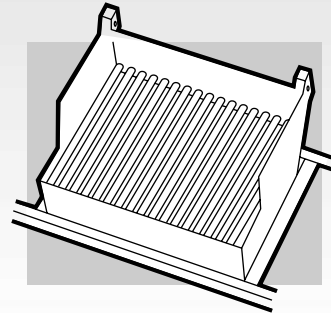

Installing the Warm-Up™ Basket

You will need: Warm-Up Basket

Insert one end of the Weber Warm-Up Basket into the hole at the right side of the inside of the lid, and the other end into the slot at the left side of the lid.

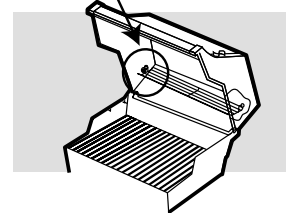
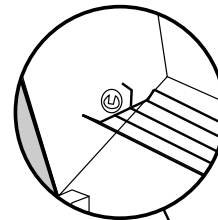

Installing the warming rack

You will need: warming rack.

Set the warming rack into the slots at the rear of the cooking box.

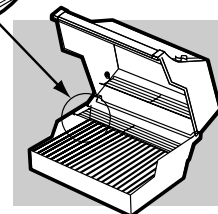
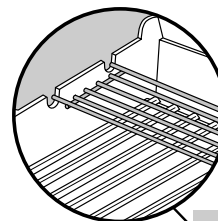

Install the thermometer

You will need: *Thermometer.*

Insert the thermometer into its holder on the right side of the lid.

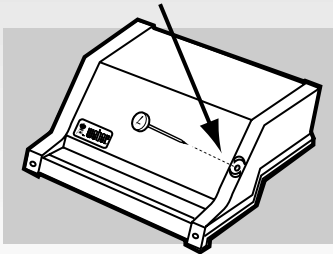

Install the bottom shelf

You will need: *Bottom shelf.*

Set the bottom shelf in place between the two frame connectors underneath the cooking box.

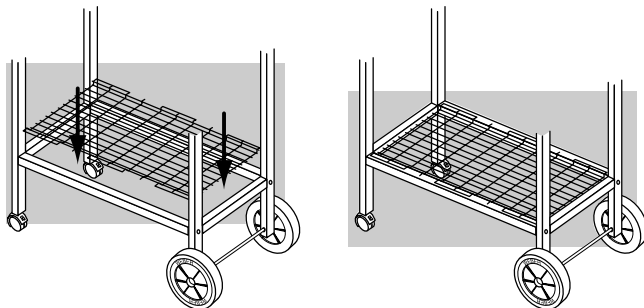

Check for gas leaks

⚠ DANGER

Do not use an open flame to check for gas leaks. Be sure there are no sparks or open flames in the area while you check for leaks. Sparks or open flames will result in a fire or explosion which can cause serious bodily injury or death and damage to property.

⚠ WARNING: You should check for gas leaks every time you disconnect and reconnect a gas fitting.

Note - All factory-made connections have been thoroughly checked for gas leaks. The burners have been flame-tested. As a safety precaution however, you should recheck all fittings for leaks before using your Weber Gas Barbecue. Shipping and handling may loosen or damage a gas fitting.

⚠ WARNING: Perform these leak checks even if your barbecue was dealer or store assembled.

You will need: a soap and water solution, and a rag or brush to apply it.

Make sure side burner is OFF. Remove valve control knob and screws. Remove porcelain top.

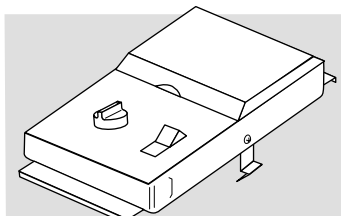

To perform leak checks: Slide back the collar of the quick disconnect. Push male fitting of the hose into the quick disconnect, and maintain pressure(1). Slide the collar closed(2). If it does not engage or lock, repeat procedure. Gas will not flow unless the quick disconnect is properly engaged.

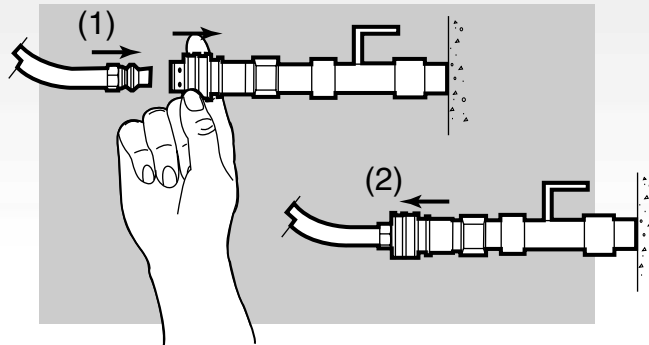

Turn on gas supply.

Check for leaks by wetting the connections with the soap and water solution and watching for bubbles. If bubbles form or if a bubble grows, there is a leak.

Note - Since some leak test solutions, including soap and water, may be slightly corrosive, all connections should be rinsed with water after checking for leaks.

⚠ WARNING: Do not ignite burners when leak checking.

Check:

- 1) Hose to manifold connection
- 2) Manifold to side burner hose connection
- ⚠ **WARNING: If there is a leak at connection(1), retighten the fitting with a wrench and recheck for leaks with soap and water solution.**
- 3) Side burner hose to side burner connection
- 4) Valves to manifold connections
- 5) Hose to quick disconnect connection

⚠ **WARNING: If there is a leak at connections(2),(3),(4) or(5), turn OFF the gas. DO NOT OPERATE THE BARBECUE. Contact the Customer Service Representative in your region using the contact information sheet provided with your manual.**

When leak checks are complete, turn gas supply OFF at the source and rinse connections with water.

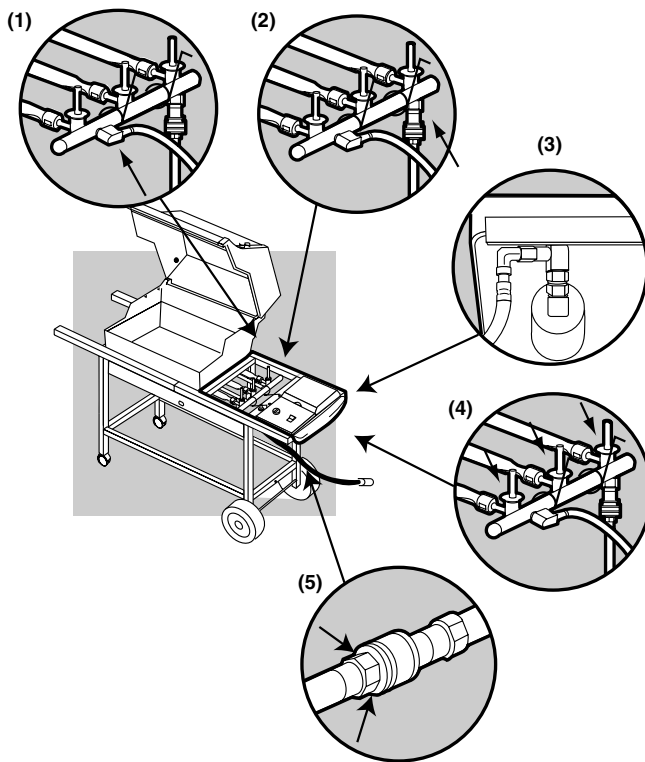

Operating

Lighting

Summary lighting instructions are on the control panel.

⚠ DANGER

Failure to open the lid while igniting the barbecue's burners, or not waiting 5 minutes to allow the gas to clear if the barbecue does not light, may result in an explosive flame-up which can cause serious bodily injury or death.

Crossover Ignition® System

Note - The Crossover Ignition System ignites the Front burner with a spark from the igniter electrode inside the Gas Catcher™ Ignition Chamber. You generate the energy for the spark by pushing the Crossover Ignition Button until it clicks.

⚠ **WARNING:** Check hose before each use of barbecue for nicks, cracking, abrasions or cuts. If the hose is found to be damaged in any way, do not use the barbecue. Replace using only Weber authorized replacement hose. Contact the Customer Service Representative in your region using the contact information sheet provided with your manual.

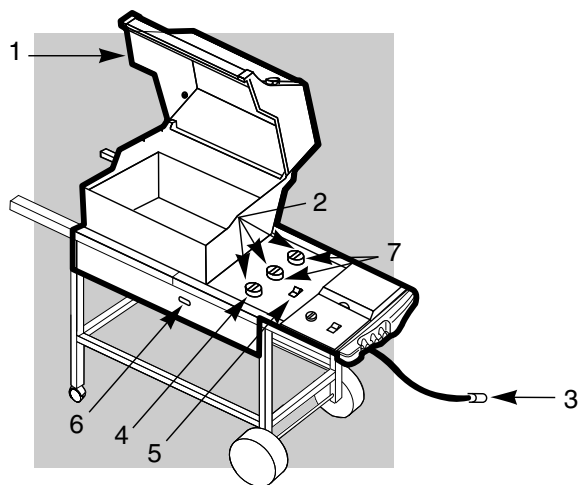

*The grill illustrated may have slight differences than the model purchased.

- 1) Open the lid.
- 2) Make sure all burner control knobs are turned OFF. (Push each burner control knob down and turn clockwise to ensure that they are in the off position.)
- 3) Turn the gas supply valve on.
⚠ **WARNING:** Do not lean over the open barbecue. Keep your face and body at least one foot away from the matchlight hole when lighting the barbecue.
- 4) Push Front burner control knob down and turn to START/HI.
- 5) Push the Crossover Ignition Button several times, so it clicks each time.
- 6) Check that the burner is lit by looking through the matchlight hole on the front of the cooking box. You should see flame.
⚠ **WARNING:** If the burner does not light, turn the Front burner control knob to OFF and wait 5 minutes to let the gas clear before you try again, or try to light with a match.
- 7) After the FRONT burner is lit you can turn on the other burner or burners.
Note - Always light the FRONT burner first. The other burner or burners ignite from the FRONT burner.

To Extinguish

Push down and turn each burner control knob clockwise to the OFF position. Turn gas supply OFF at the source.

Manual Lighting

⚠ DANGER

Failure to open lid while igniting the barbecue's burners, or not waiting 5 minutes to allow the gas to clear if the barbecue does not light, may result in an explosive flame-up which can cause serious bodily injury or death.

- 1) Open the lid.
- 2) Make sure all burner control knobs are turned OFF. (Push each burner control knob down and turn clockwise to ensure they are in the off position.)
- 3) Turn the gas supply valve on.
- 4) Strike a match and put the flame into the matchlight hole in the front of the cooking box.

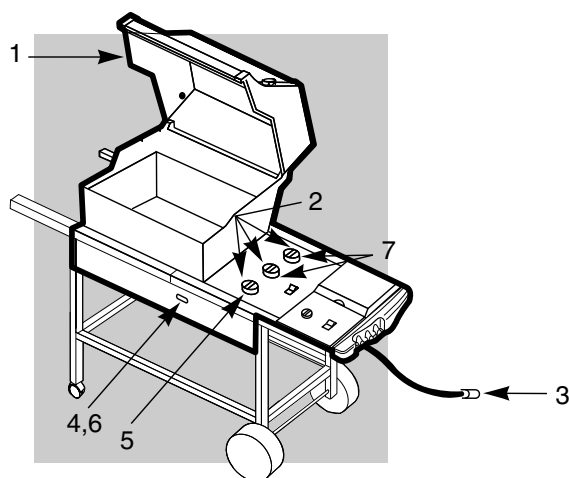

*The grill illustrated may have slight differences than the model purchased.

⚠ WARNING: Do not lean over the open barbecue. Keep your face and body at least one foot away from the matchlight hole when lighting the barbecue.

- 5) Push Front burner control knob down and turn to START/HI.
- 6) Check that the burner is lit by looking through the matchlight hole on the front of the cooking box. You should see a flame.

⚠ WARNING: If the burner does not light, turn the Front burner control knob to OFF and wait 5 minutes to let the gas clear before you try again or try to light with a match.

- 7) After the FRONT burner is lit you can turn on the other burner or burners.

Note - Always light the FRONT burner first. The other burner or burners ignite from the FRONT burner.

To Extinguish

Push down and turn each burner control knob clockwise to the OFF position. Turn gas supply OFF at the source.

Lighting the Side Burner

The side burner has a separate ignition system from the main cooking box.

⚠ DANGER

Failure to open the lid while igniting the side burner, or not waiting 5 minutes to allow the gas to clear if the side burner does not light, may result in an explosive flame-up which can cause serious bodily injury or death.

Lighting only the side burner.

- 1) Open the side burner lid.
- 2) Check that the side burner valve is turned OFF. (Push each knob down and turn clockwise to ensure they are in the off position.), and all main burner control valves are OFF (push down and turn clockwise).
- 3) Turn the gas supply valve on.
- 4) Push down and turn the side burner control valve to HI.
- 5) Push the side burner igniter button several times so it clicks each time.

⚠ CAUTION: Side burner flame may be difficult to see on a bright sunny day.

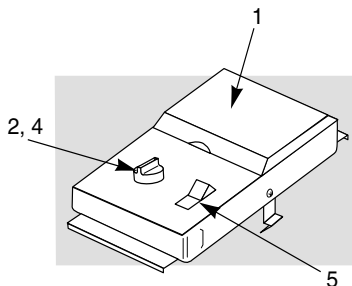

⚠ WARNING: If the side burner does not light:

- 1) Turn OFF the side burner control valve.
- 2) Wait 5 minutes to let the gas clear before you try again or try to light with a match.

Lighting the side burner if the main burners are lit.

- 1) Open the side burner lid.
- 2) Push down and turn the side burner control to HI.
- 3) Press the side burner igniter button several times so it clicks each time.

⚠ CAUTION: Side burner flame may be difficult to see on a bright sunny day.

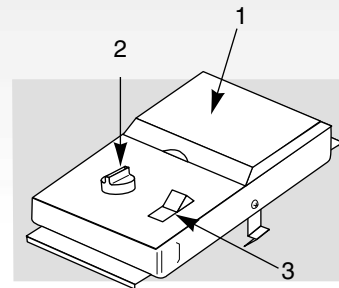

⚠ WARNING: If the side burner does not light:

- 1) Turn OFF the side burner control valve.
- 2) Wait 5 minutes to let the gas clear before you try again or try to light with a match.

Cooking

⚠ WARNING: Do not move the Weber Gas Barbecue when operating or while barbecue is hot.

You can adjust the FRONT and BACK burners as desired. The control settings: High (H), Medium (M), Low (L), or Off (O) are described in your Weber cookbook. The cookbook uses these notations to describe the settings of the FRONT and BACK burners. For example, to sear steaks, you would set all burners at H (high). Then to complete cooking, you would set FRONT and BACK at M (medium). Refer to your Weber cookbook for detailed cooking instructions.

Note: The temperature inside your cooking box for the first few uses, while surfaces are still very reflective, may be hotter than those shown in your cookbook. Cooking conditions. Such as wind and weather, may require the adjustment of the burner controls to obtain the correct cooking temperatures.

⚠ CAUTION: Replace thermometer in lid when not in use. Do not leave thermometer in food while cooking.

If burners go out during cooking, open lid, turn off all burners and wait five minutes before relighting.

Preheating - Your Weber Gas Barbecue is an energy-efficient appliance. It operates at an economical low BTU rate. To preheat: after lighting, close lid and turn all burners to high (HH). Preheating to between 500° and 550° F (260° and 290° C) will take 10 to 15 minutes depending on conditions such as air temperature and wind.

Drippings and grease - The Flavorizer® Bars are designed to “smoke” the correct amount of drippings for flavorful cooking. Excess drippings and grease will accumulate in the catch pan under the slide out bottom tray. Disposable foil drip pans are available that fit the catch pan.

⚠ WARNING: Check the bottom tray for grease build-up before each use. Remove excess grease to avoid a grease fire in the slide out bottom tray.

Storage

■ When storing the Weber Gas Barbecue, make sure that the inside shut-off valve and/or locking outdoor shut-off valve is secured in the OFF position. When the Weber Gas Barbecue is stored indoors, the gas supply **MUST BE DISCONNECTED.**

■ After a period of storage and/or nonuse, the Weber Gas Grill should be checked for gas leaks and any obstructions in the burner tubes before using. (See “Maintenance” Section.)

- Check that the areas under the control panel and the slide out bottom tray are free from debris that might obstruct the flow of combustion or ventilation air.
- The Spider /Insect Screens should also be checked for any obstructions. (See “Maintenance” Section.)

Cleaning

⚠ WARNING: Turn your Weber Gas Barbecue OFF and wait for it to cool before cleaning.

⚠ CAUTION: Do not clean your Flavorizer® Bars or cooking grates in a self-cleaning oven.

For availability of replacement cooking grates and Flavorizer Bars contact the Customer Service Representative in your region using the contact information sheet provided with your manual.

Outside surfaces - Use a warm soapy water solution to clean, then rinse with water.

⚠ CAUTION: Do not use oven cleaner, abrasive cleansers (kitchen cleansers) cleaners that contain citrus products, or abrasive cleaning pads on barbecue or cart surfaces.

Slide out Bottom tray - Remove excess grease, then wash with warm soapy water, then rinse

Flavorizer® Bars and Cooking Grates - Clean with a suitable brass bristle brush. As needed, remove from grill and wash with warm soapy water, then rinse with water.

Catch pan - Disposable foil trays are available, or you can line the catch pan with aluminum foil. To clean the catch pan, wash with warm soapy water, then rinse.

Thermometer - Wipe with warm soapy water; clean with plastic scrub ball. Do not put in dishwasher or submerge in water.

Inside cooking module - Brush any debris off of burner tubes. **DO NOT ENLARGE BURNER PORTS (OPENINGS).** Wash inside of cooking box with warm soapy water and a water rinse.

Inside Lid - While lid is warm, wipe inside with paper towel to prevent grease build-up. Flaking built-up grease resembles paint flakes.

Stainless steel surfaces - Wash with a soft cloth and a soap and water solution.

Thermoset surfaces - Wash with a soft cloth and a soap and water solution.

Do not use cleaners that contain acid, mineral spirits or xylene. Rinse well after cleaning.

Thermoset work surfaces are not to be used as cutting boards.

Annual Maintenance

After a period of nonuse, we recommend that you perform the following maintenance procedures for your safety.

⚠ WARNING: Check the hose before each use of the barbecue for nicks, cracking, abrasions or cuts. If the hose is found to be damaged in any way, do not use the barbecue. Replace using only Weber authorized replacement hose. Contact the Customer Service Representative in your region using the contact information sheet provided with your manual.

■ Inspect the burners for correct flame pattern. Clean if necessary, following the procedures outlined in the "General Maintenance" section of this manual.

■ Check all gas fittings for leaks.

⚠ DANGER

Do not use an open flame to check for gas leaks. Be sure there are no sparks or open flames in the area while you check for leaks. Sparks or flames will result in a fire or explosion, which can cause serious bodily injury or death, and damage to property.

⚠ WARNING: You should check for gas leaks every time you disconnect and reconnect a gas fitting.

Note - All factory-made connections have been thoroughly checked for gas leaks. The burners have been flame tested. As a safety precaution however, you should recheck all fittings for leaks before using your Weber Gas Barbecue. Shipping and handling may have loosened or damaged a gas fitting.

⚠ WARNING: Perform these leak checks even if your barbecue was dealer- or store-assembled.

You will need: a soap and water solution and a rag or brush to apply it.

To perform leak checks: Make sure all Burners are in the off position. Turn on gas supply.

⚠ WARNING: Do not ignite burners while leak checking.

Check for leaks by wetting the connections with the soap and water solution and watching for bubbles. If bubbles form, or if a bubble grows, there is a leak.

Note - Since some leak test solutions, including soap and water, may be slightly corrosive, all connections should be rinsed with water after checking for leaks.

Check:

1) Hose to manifold connections.

⚠ WARNING: If there is a leak at connection (1), re-tighten the fitting with a wrench and recheck for leaks with a soap and water solution.

If a leak persists after re-tightening the fitting, turn OFF the gas. **DO NOT OPERATE THE BARBECUE.** Contact the Customer Service Representative in your region using the contact information sheet provided with your manual.

- 2) Manifold to side burner hose connection
- 3) Side burner hose to side burner connection
- 4) Valves to manifold connection.
- 5) Hose to quick disconnect connection.

⚠ WARNING: If there is a leak at connections (2,3,4 Or 5), turn OFF the gas. **DO NOT OPERATE THE BARBECUE.** Contact the Customer Service Representative in your region using the contact information sheet provided with your manual.

When leak checks are complete, turn gas supply OFF at the source and rinse connections with water.

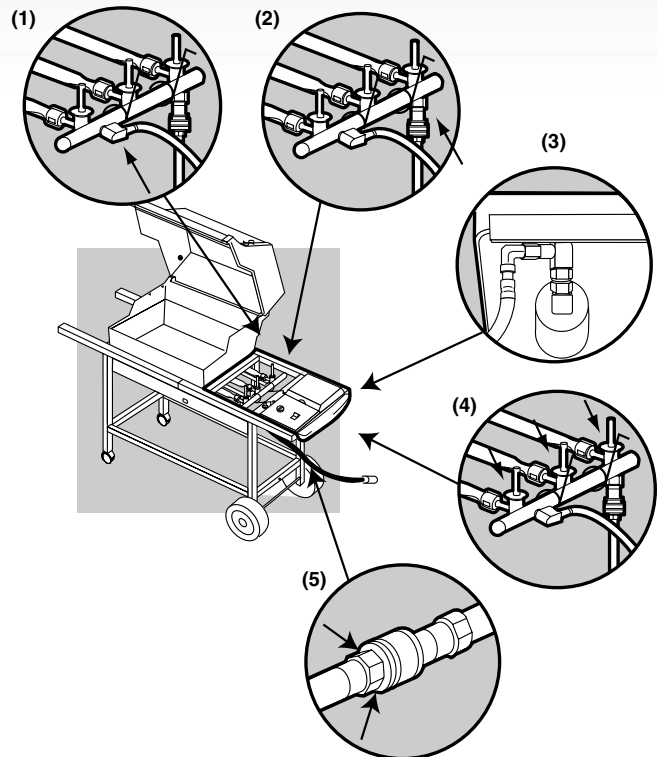

*The grill illustrated may have slight differences than the model purchased.

Inspection and cleaning of the Spider/Insect screens

To inspect the spider/insect screens, remove the control panel. If there is dust or dirt on the screens, remove the burners for cleaning the screens. Refer to **Maintenance, Replacing Main Burners**. Brush the spider/insect screens, lightly, with a soft bristle brush (i.e. an old toothbrush).

⚠ Caution: Do not clean the spider/insect screens with hard or sharp tools. Do not dislodge the spider/insect screens or enlarge the screen openings.

Lightly tap the burner to get debris and dirt out of the burner tube. Once the spider/insect screens and burners are clean replace the burners.

If the spider/insect screen becomes damaged or cannot be cleaned, call Weber-Stephen Products Customer Service for replacement parts.

General Maintenance

Weber Spider /Insect screens

Your Weber Gas Barbecue, as well as any outdoor gas appliance, is a target for spiders and other insects. They can nest in the venturi section Venturi(1). This blocks the normal gas flow, and can cause the gas to flow back out of the air shutter. This could result in a fire in and around the air shutters, under the control panel, causing serious damage to your barbecue.

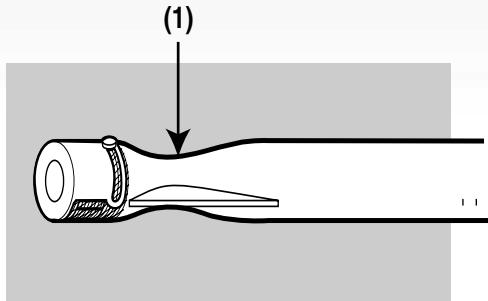

The burner tube air shutter is fitted with a stainless steel screen(1) to prevent spiders and other insects access to the burner tubes through the air shutter openings.

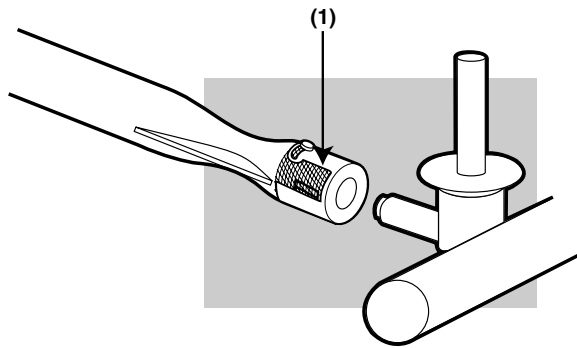

We recommend that you inspect the Spider/Insect screens at least once a year. (See Section “Annual Maintenance”.) Also inspect and clean the the Spider/Insect screens if any of the following symptoms should ever occur:

- 1) The smell of gas in conjunction with the burner flames appearing yellow and lazy.
- 2) Barbecue does not reach temperature.
- 3) Barbecue heats unevenly.
- 4) One or more of the burners do not ignite.

⚠ DANGER

Failure to correct the above mentioned symptoms may result in a fire, which can cause serious bodily injury or death, and cause damage to property.

Main Burner Flame Pattern

The Weber Gas Barbecue burners have been factory set for the correct air and gas mixture. The correct flame pattern is shown.

- 1) Burner tube
- 2) Tips occasionally flicker yellow
- 3) Light blue
- 4) Dark blue

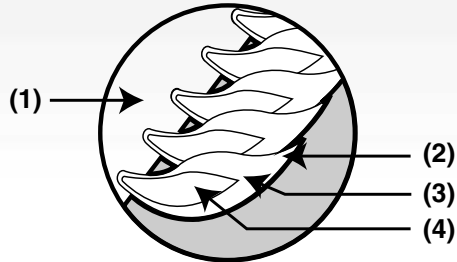

If the flames do not appear to be uniform throughout the burner tube, follow the burner cleaning procedures.

Main Burner Cleaning Procedure

Turn off the gas supply. Remove the manifold. Look inside each burner with a flashlight.

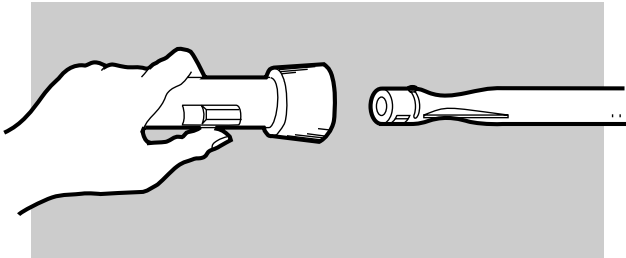

Clean the inside of the burners with a wire (a straightened-out coat hanger will work). Check and clean the air shutter opening at the ends of the burners. Check and clean the valve orifices at the base of the valves. Use a brass bristle brush to clean outside of burners. This is to make sure all the burner ports are fully open.

CAUTION: Do not enlarge the burner ports when cleaning.

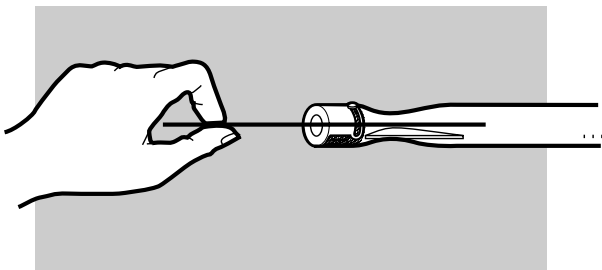

Replacing Main Burners

- 1) Your Weber Gas Barbecue must be OFF and cool.
- 2) Turn gas OFF at source.
- 3) To remove control panel: take off the burner control knobs. Remove the screws holding the control panel in place. Lift off the control panel.
- 4) Unhook the manifold bracket(1) and unscrew the two wing nuts(2) that hold the manifold to the cooking box. Pull the manifold and valve assembly out of the burners and carefully set it down.

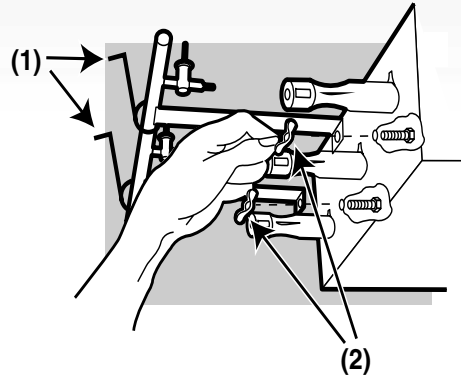

- 5) Slide the burner assembly out from under the guide screw and washer(1) in the corners of the cooking box.

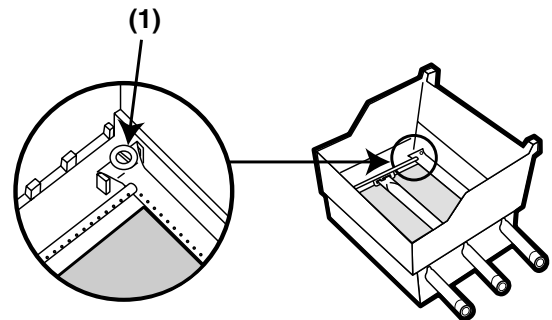

- 6) Lift and twist the burner assembly slightly, to separate the crossover tube(1) from the burners. Remove the burners from the cooking box.

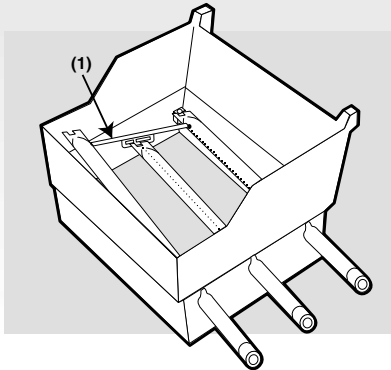

- 7) To reinstall the burners, reverse 3) through 7). **⚠ CAUTION: The burner openings(1) must be positioned properly over the valve orifices(2).** Check proper assembly before fastening manifold in place.

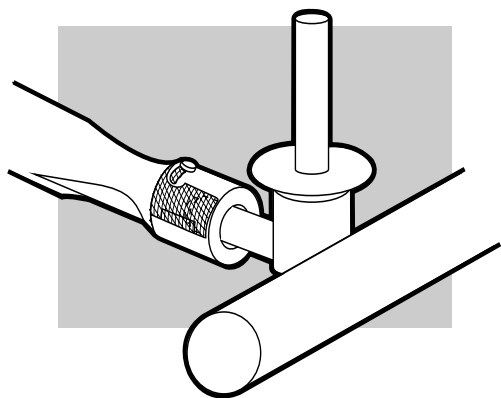
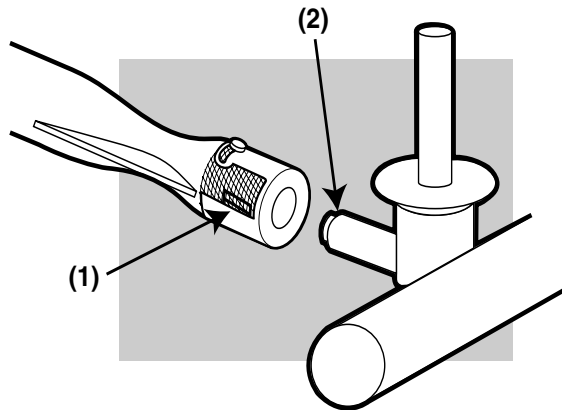

⚠ WARNING: After reinstalling the gas lines, they should be leak checked with a soap and water solution before using the barbecue. (See Step: "Check for gas leaks.")

Crossover® Ignition System Operations

If the Crossover Ignition System fails to ignite the Left burner, light the Left burner with a match. If the Left burner lights with a match, then check the Crossover Ignition System.

- Check that both the white(1) and black(2) ignition wires are attached properly.

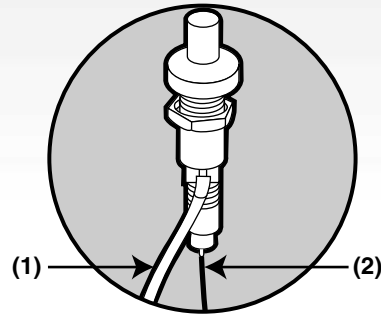

- Check that the Crossover Ignition button pushes the igniter (button) down, and returns to the up position.
 - Check to see if the igniter is loose in the frame. Tighten if necessary; See Step "Install igniter" for correct procedure.
- If the Crossover Ignition System still fails to light, Contact the Customer Service Representative in your region using the contact information sheet provided with your manual.

Troubleshooting

Problem	Check	Cure
Burners burn with a yellow or orange flame, in conjunction with the smell of gas.	Inspect Spider/Insect Screens for possible obstructions. (Blockage of holes.)	Clean Spider/Insect Screens. (See Section "Annual Maintenance")
Burner does not light, or flame is low in HIGH position.	Is fuel hose bent or kinked?	Straighten fuel hose.
	Does the Front burner light with a match?	If you can light the Front burner with a match, then check the Crossover Ignition System.
Experiencing flare-ups: ⚠ CAUTION: Do not line the bottom tray with aluminum foil.	Are you preheating barbecue in the prescribed manner?	All burners on high for 10 to 15 minutes for preheating.
	Are the cooking grates and Flavorizer bars heavily coated with burned-on grease?	Clean thoroughly. (See Section "Cleaning")
	Is the bottom tray "dirty" and not allowing grease to flow into catch pan?	Clean bottom tray
Burner flame pattern is erratic. Flame is low when burner is on HIGH. Flames do not run the whole length of the burner tube.	Are burners clean?	Clean burners. (See Section "General Maintenance".)
Inside of lid appears to be "peeling." (Resembles paint peeling.)	The lid is porcelain-on-steel, not paint. It cannot "peel". What you are seeing is baked on grease that has turned to carbon and is flaking off. THIS IS NOT A DEFECT.	Clean thoroughly. (See Section "Cleaning".)
If problems cannot be corrected by using these methods, please contact the Customer Service Representative in your region using the contact information sheet provided with your manual.		

Side Burner Troubleshooting

⚠ WARNING: Before attempting any troubleshooting steps, all gas controls and supply valves should be in the OFF position.

Problem	Check	Cure
Side Burner does not light.	Is gas supply off?	Turn supply on.
Flame is low in HIGH position.	Is the fuel hose bent or kinked?	Straighten hose.
Flame is very yellow in conjunction with the smell of gas, OR Burner makes popping noise in conjunction with the smell of gas.	Inspect the Spider/Insect Screens for possible obstructions. (lockage of holes.)	Clean Spider/Insect Screens. (See section "Annual Maintenance")
Push button ignition does not work.	Does burner light with a match?	If match lights burner, check igniter (see below).

Side Burner maintenance

⚠ WARNING: All gas controls and supply valves should be in the OFF position.

Check igniter: Remove side burner cover. To remove side burner cover, remove control knob and screws that hold cover to bottom(1).

Make sure wire is connected between igniter and electrode. Check that igniter lock nut is tight.

Note: If the igniter works loose, carefully tighten the igniter lock nut with an adjustable wrench or pliers.

Adjust igniter electrode to burner. Gap should be 1/8 to 3/16 inch from tip of electrode to burner. Spark should be a white/blue color, not yellow.

- 1) Igniter
- 2) Igniter Wire
- 3) Venturi/Burner
- 4) 1/8 to 3/16 inch gap between electrode and burner

