



GENESIS[®] *Platinum C*

Natural Gas Grill Owners Guide

**YOU MUST READ THIS OWNERS GUIDE
BEFORE OPERATING YOUR GAS GRILL**

#

⚠ DANGER

If you smell gas:

1. Shut off gas to the appliance.
2. Extinguish any open flames.
3. Open lid
4. If odor continues, keep away from the appliance and immediately call your gas supplier or your fire department.

Leaking gas may cause a fire or explosion which can cause serious bodily injury or death, or damage to property.

⚠ WARNING

1. Do not store spare liquid propane cylinder within 10 feet (3m) of this appliance.
2. Do not store or use gasoline or other flammable liquids or vapors within 25 feet (8m) of this appliance.

⚠ WARNING: Follow all leak-check procedures carefully in this manual prior to barbecue operation. Do this even if the barbecue was dealer-assembled.

NOTICE TO INSTALLER: These instructions must be left with the owner and the owner should keep them for future use.

**THIS GAS APPLIANCE IS DESIGNED FOR
OUTDOOR USE ONLY.**

⚠ WARNING: Do not try to light this appliance without reading the "Lighting" Instructions section of this manual

A260_NG.b
B212_NG.a
C220_NG.b
D218_NG.a
E204.a



55342 01/30/02
NG
US English

⚠ Dangers & ⚠ Warnings

⚠ DANGER

Failure to follow the Dangers, Warnings and Cautions contained in this Owner's Manual may result in serious bodily injury or death, or in a fire or an explosion causing damage to property.

⚠ WARNINGS

- ⚠ Do not store a spare or disconnected liquid propane cylinder under or near this barbecue.
- ⚠ Improper assembly may be dangerous. Please carefully follow the assembly instructions in this manual.
- ⚠ After a period of storage, and/or nonuse, the Weber® gas barbecue should be checked for gas leaks and burner obstructions before use. See instructions in this manual for correct procedures.
- ⚠ Do not operate the Weber® gas barbecue if there is a gas leak present.
- ⚠ Do not use a flame to check for gas leaks.
- ⚠ Combustible materials should never be within 24 inches of the top, bottom, back or sides of your Weber® gas barbecue.
- ⚠ Do not put a barbecue cover or anything flammable on, or in the storage area under the barbecue.
- ⚠ Your Weber® gas barbecue should never be used by children. Accessible parts of the barbecue may be very hot. Keep young children away while it is in use.
- ⚠ You should exercise reasonable care when operating your Weber® gas barbecue. It will be hot during cooking or cleaning and should never be left unattended, or moved while in operation.
- ⚠ Should the burners go out while in operation, turn all gas valves off. Open the lid and wait five minutes before attempting to relight, using the lighting instructions.
- ⚠ Do not use charcoal or lava rock in your Weber® gas barbecue.
- ⚠ Never lean over open grill or place hands or fingers on the front edge of the cooking box.
- ⚠ Should a grease fire occur, turn off all burners and leave lid closed until fire is out.
- ⚠ Do not enlarge valve orifices or burner ports when cleaning the valves or burners.
- ⚠ The Weber® gas barbecue should be thoroughly cleaned on a regular basis.
- ⚠ Liquid propane gas is not natural gas. The conversion or attempted use of natural gas in a liquid propane unit or liquid propane gas in a natural gas unit is dangerous and will void your warranty.
- ⚠ Do not attempt to disconnect any gas fitting while your barbecue is in operation.
- ⚠ Use heat-resistant barbecue mitts or gloves when operating barbecue.
- ⚠ Combustion byproducts produced when using this product contain chemicals known to the state of California to cause cancer, birth defects, or other reproductive harm.

LIQUID PROPANE GAS UNITS ONLY:

- ⚠ Use the regulator that is supplied with your Weber® gas barbecue.
- ⚠ Do not attempt to disconnect the gas regulator or any gas fitting while your barbecue is in operation.
- ⚠ A dented or rusty liquid propane cylinder may be hazardous and should be checked by your liquid propane supplier. Do not use a liquid propane cylinder with a damaged valve.
- ⚠ Although your liquid propane cylinder may appear to be empty, gas may still be present, and the cylinder should be transported and stored accordingly.
- ⚠ If you see, smell or hear the hiss of escaping gas from the liquid propane cylinder:
 1. Move away from liquid propane cylinder.
 2. Do not attempt to correct the problem yourself.
 3. Call your fire department.

Contents



Danger & Warnings A-2

Warranty A-4



General Instructions A-5

Cooking A-6



Cleaning A-6

Exploded View A-7



Parts List A-9

Unpacking A-10



Assembly Instructions B-1

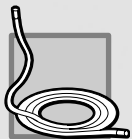

Gas Instructions C-1

Leak Checking C-2



Operating D-1



Lighting D-1

Manual Lighting D-2

Lighting the Side Burner D-3

Troubleshooting D-4



Side Burner Troubleshooting D-5

Maintenance E-1

Replacing Main Burners E-2

Crossover® Ignition System Operations E-2

Warranty

Weber-Stephen Products Co. (Weber) hereby warrants to the ORIGINAL PURCHASER of this Weber® gas grill that it will be free of defects in material and workmanship from the date of purchase as follows:

Aluminum Castings,	lifetime, 1 year paint
Stainless Steel Hood Section,	25 years
Stainless Steel Side Table,	25 years
Burners,	10 years
Igniter,	3 years
Cooking Grates,	7 years no rust through
Flavorizer Bars,	5 year no rust through
All Remaining Parts,	5 years,

when assembled and operated in accordance with the printed instructions accompanying it.

Weber may require reasonable proof of your date of purchase. THEREFORE, YOU SHOULD RETAIN YOUR SALES SLIP OR INVOICE.

This Limited Warranty shall be limited to the repair or replacement of parts that prove defective under normal use and service and which on examination shall indicate, to Weber's satisfaction, they are defective. Before returning any parts, contact the Customer service representative in your region using the contact information sheet provided with your manual. If Weber® confirms the defect and approves the claim, Weber® will elect to replace such parts without charge. If you are required to return defective parts, transportation charges must be prepaid. Weber® will return parts to the purchaser, freight or postage prepaid.

This Limited Warranty does not cover any failures or operating difficulties due to accident, abuse, misuse, alteration, misapplication, vandalism, improper installation or improper maintenance or service, or failure to perform normal and routine maintenance, including but not limited to damage caused by insects within the burner tubes, as set out in this owner's manual.

Deterioration or damage due to severe weather conditions such as hail, hurricanes, earthquakes or tornadoes, discoloration due to exposure to chemicals either directly or in the atmosphere, is not covered by this Limited Warranty.

There are no other express warrants except as set forth herein and any applicable implied warranties of merchantability and fitness are limited in duration to the period of coverage of this express written Limited Warranty. Some regions do not allow limitation on how long an implied warranty lasts, so this limitation may not apply to you.

Weber® is not liable for any special, indirect or consequential damages. Some regions do not allow the exclusion or limitation of incidental or consequential damages, so this limitation or exclusion may not apply to you.

Weber® does not authorize any person or company to assume for it any other obligation or liability in connection with the sale, installation, use, removal, return, or replacement of its equipment; and no such representations are binding on Weber®.

This Warranty applies only to products sold at retail.

WEBER-STEPHEN PRODUCTS CO.
Customer Service Center
1890 Roselle Road, Suite 308
Schaumburg, IL 60195
USA

General Instructions

Your Weber® gas barbecue is a portable outdoor cooking appliance. With the Weber® gas barbecue you can grill, barbecue, roast and bake with results that are difficult to duplicate with indoor kitchen appliances. The closed lid and Flavorizer® bars produce that “outdoor” flavor in the food.

The Weber® gas barbecue is portable so you can easily change its location in your yard or on your patio. Portability means you can take your Weber® gas barbecue with you if you move.

The natural gas supply is easy to use and gives you more cooking control than charcoal fuel.

- These instructions will give you the minimum requirements for assembling your Weber® gas barbecue. Please read the instructions carefully before using your Weber® gas barbecue. Improper assembly can be dangerous.
- Not for use by children.
- If there are local codes that apply to portable gas grills, you will have to conform to them. If there are no local codes, you must conform to the latest edition of the National Fuel Gas Code: ANSI Z 223.1.
- This Weber® gas barbecue is designed for natural (piped in city) gas only. Do not use liquid propane (LP) bottled gas. The valves, orifices and hose are for natural gas only.
- Do not use with charcoal fuel.
- Check that the area under the control panel and the bottom tray are free from debris that might obstruct the flow of combustion or ventilation air.

For Installation in Canada

These instructions, while generally acceptable, do not necessarily comply with the Canadian Installation codes, particularly with piping above and below ground. In Canada the installation of this appliance must comply with local codes and/or Standards CAN/CGA-B149.1 (Installation Code for Natural Gas Burning Appliances and Equipment).

Storage

- The gas must be turned OFF at the natural gas supply when the Weber® gas barbecue is not in use.
- When the Weber® gas barbecue is stored indoors, the gas supply must be disconnected.
- The Weber® gas barbecue should be checked for gas leaks and any obstructions in the burner tubes before using. (See Sections: “General Maintenance and Annual Maintenance.”)
- Check that the areas under the control panel and the slide out bottom tray are free from debris that might obstruct the flow of combustion or ventilation air.
- The Spider /Insect Screens should also be checked for any obstructions. (See Section: “Annual Maintenance.”)

Operating

- ▲ **WARNING: Only use this barbecue outdoors in a well-ventilated area. Do not use in a garage, building, breezeway or any other enclosed area.**
- ▲ **WARNING: Never use your Weber® gas barbecue under an unprotected combustible roof or overhang.**
- ▲ **WARNING: Your Weber® gas barbecue is not intended to be installed in or on recreational vehicles and/or boats.**
- ▲ **WARNING: Do not use combustible materials within 24 inches of the top, bottom, back or sides of the grill.**
- ▲ **WARNING: The entire cooking box gets hot when in use. Do not leave unattended.**
- ▲ **WARNING: Keep any electrical supply cord and the fuel supply hose away from any heated surface.**
- ▲ **WARNING: Keep the cooking area clear of flammable vapors and liquids, such as gasoline, alcohol, etc., and combustible materials.**

Gas Supply Testing

- Disconnect your Weber® gas barbecue when the gas supply is being tested at high pressures. This appliance and its individual shutoff valve must be disconnected from the gas supply piping system during any pressure testing of that system at test pressures in excess of 1/2 psig (3.5 kPa).
- Turn OFF your Weber® gas barbecue when the gas supply is being tested at low pressures. This appliance must be isolated from the gas supply piping system by closing its individual manual shutoff valve during any pressure testing of the gas supply piping system at the pressure equal to or less than 1/2 psig (3.5 kPa).

General Instructions

Cooking

⚠ **WARNING: Do not move the Weber® gas barbecue when operating or while barbecue is hot.**

You can adjust the FRONT and BACK burners as desired. The control settings: High (H), Medium (M), Low (L), or Off (O) are described in your Weber® cookbook. The cookbook uses these notations to describe the settings of the FRONT and BACK burners. For example, to sear steaks, you would set all burners at H (high). Then to complete cooking, you would set FRONT and BACK at M (medium). Refer to your Weber® cookbook for detailed cooking instructions.

Note: The temperature inside your cooking box for the first few uses, while surfaces are still very reflective, may be hotter than those shown in your cookbook. Cooking conditions. Such as wind and weather, may require the adjustment of the burner controls to obtain the correct cooking temperatures.

⚠ **CAUTION: Replace thermometer in lid when not in use. Do not leave thermometer in food while cooking.**

If burners go out during cooking, open lid, turn off all burners and wait five minutes before relighting.

Preheating - Your Weber® gas barbecue is an energy-efficient appliance. It operates at an economical low BTU rate. To preheat: after lighting, close lid and turn all burners to high (HH). Preheating to between 500° and 550° F (260° and 290° C) will take 10 to 15 minutes depending on conditions such as air temperature and wind.

Drippings and grease - The Flavorizer® bars are designed to “smoke” the correct amount of drippings for flavorful cooking. Excess drippings and grease will accumulate in the catch pan under the slide out bottom tray. Disposable foil drip pans are available that fit the catch pan.

⚠ **WARNING: Check the bottom tray for grease build-up before each use. Remove excess grease to avoid a grease fire in the slide out bottom tray.**

Cleaning

⚠ **WARNING: Turn your Weber® gas barbecue OFF and wait for it to cool before cleaning.**

⚠ **CAUTION: Do not clean your Flavorizer® bars or cooking grates in a self-cleaning oven.**

For availability of replacement cooking grates and Flavorizer® bars contact the Customer Service Representative in your region using the contact information sheet provided with your manual.

Outside surfaces - Use a warm soapy water solution to clean, then rinse with water.

⚠ **CAUTION: Do not use oven cleaner, abrasive cleansers (kitchen cleansers) cleaners that contain citrus products, or abrasive cleaning pads on barbecue or cart surfaces.**

Slide out Bottom tray - Remove excess grease, then wash with warm soapy water, then rinse

Flavorizer® bars and Cooking grates - Clean with a suitable brass bristle brush. As needed, remove from grill and wash with warm soapy water, then rinse with water.

Catch pan - Disposable foil trays are available, or you can line the catch pan with aluminum foil. To clean the catch pan, wash with warm soapy water, then rinse.

Thermometer - Wipe with warm soapy water; clean with plastic scrub ball. Do not put in dishwasher or submerge in water.

Inside cooking module - Brush any debris off of burner tubes. **DO NOT ENLARGE BURNER PORTS (OPENINGS).** Wash inside of cooking box with warm soapy water and a water rinse.

Inside Lid - While lid is warm, wipe inside with paper towel to prevent grease build-up. Flaking built-up grease resembles paint flakes.

Stainless steel surfaces - Wash with a soft cloth and a soap and water solution. Be careful to scrub with the grain direction of the stainless steel.

Thermoset surfaces - Wash with a soft cloth and a soap and water solution.

Do not use cleaners that contain acid, mineral spirits or xylene. Rinse well after cleaning.

Thermoset work surfaces are not to be used as cutting boards.

General Instructions

Using the Smoker Box

The Smoker cooks with both Weber FireSpice® Wood Chips and Chunks. For best results with faster cooking foods like steaks, burgers and chops, etc., we recommend using the FireSpice® Chips because they ignite and create smoke faster. For longer cooking foods such as roasts, chicken and turkeys, etc., we recommend using FireSpice® Chunks because they ignite slowly and provide smoke for a longer period of time. As you gain experience in using your smoker, we encourage you to experiment with different combinations of FireSpice® Chips and Chunks to find the smoke flavor that best suits your taste.

Cooking

As a starting point, place a couple of handfuls of FireSpice® Chips or a few FireSpice® Chunks in the bottom of the smoker body. Since the chunks vary in size, place as many as you can in the smoker. As you gain experience in smoking, increase or decrease the amount of wood to suit your taste. Close the smoker lid.

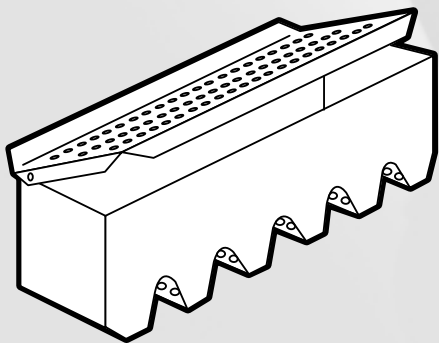

Light the barbecue and preheat with all burners on HIGH, lid down, for 10 minutes or until the wood starts to smoke. If you leave the grill in the preheat mode for too long the chips will char prematurely reducing the smoke.

IMPORTANT NOTE: Ambient temperature, type and size of wood, moisture content and wind condition will always be a large factor in your results.

Adjust the burners for cooking, MOM or LOL will be your best settings for long duration smoking. Smoke will start in approximately 10 minutes and last as long as 45 minutes. If you require more smoke flavor, refill the smoker with FireSpice® Chips and /or Chunks. The smoker may be used to enhance any of the meat, poultry and fish recipes in the gas barbecue cookbook. Cook with the lid down according to the times indicated in charts or recipes. Keep the lid of the barbecue closed while cooking.

Note - After refilling smoker, smoke will take about 10 to 15 minutes to start again.

⚠DANGER

Do not use any flammable fluid in the Smoker to ignite the wood.

Cleaning

Before each use, empty the smoker of ash to allow proper airflow. Accomplish this by tapping the sides of the smoker and stirring the ashes so that they sift through the bottom and fall into the bottom tray of your barbecue. Remove bottom tray and empty.

Note - Smoking will leave a "smoke" residue on the surface of the smoker. This residue cannot be removed and will not affect the function of the smoker. To a lesser degree a "smoke" residue will accumulate on the inside of your Weber® gas barbecue. This residue need not be removed and will not adversely affect the function of your barbecue.

Exploded View

Genesis Platinum-C NG 121599

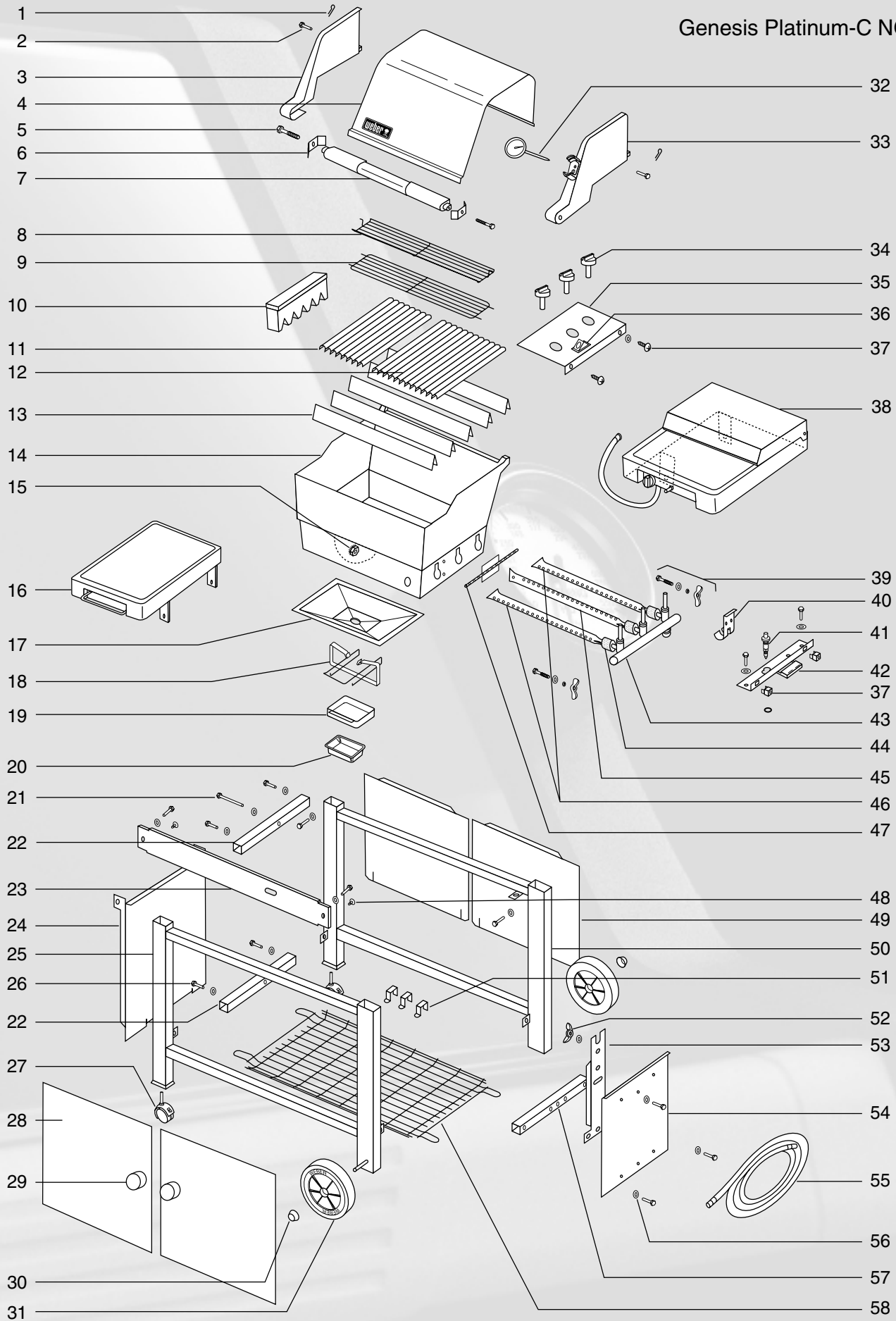

Exploded View List

1. Hair Pin Cotter
2. Hinge Pin
3. Left Endcap
4. Shroud
5. 1/4-20 x 1 1/2 inch bolt
6. Handle lock
7. Handle
8. Warm-Up™ Basket
9. Warming Rack
10. Smoker Assembly
11. Cooking Grate (Small)
12. Cooking Grate (Large)
13. Flavorizer® Bars
14. Cooking Box
15. 1/4-20 keps nut
16. Work Surface
17. Slide Out Bottom Tray
18. Catch Pan Holder
19. Catch Pan
20. Drip Pans
21. 1/4 - 20 x 2 inch Bolt
22. Frame Connector
23. Front Panel
24. Left Side Panel
25. Front Frame
26. 1/4-20 x 1/2 inch bolt
27. Casters
28. Doors
29. Door Knobs
30. Hubcaps
31. Wheels
32. Thermometer
33. Right Endcap
34. Burner Control Knobs
35. Control Panel
36. Igniter Button
37. Control Panel Hardware
38. Side Burner Assembly
39. Manifold Hardware
40. Manifold Support Bracket
41. Igniter
42. Igniter Bracket
43. Manifold
44. Spider Stopper Guards
45. Center Burner
46. Front and Back Burners
47. Crossover Tube
48. Plastic Buttons
49. Rear Panel
50. Rear Frame
51. Tool Holders
52. Wing Nut
53. Cylinder Panel
54. Right Side Panel
55. Hose
56. Nylon Washer
57. Frame Connector
58. Bottom Shelf

Parts List

You will need:

Phillips screwdriver

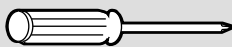

7/16 open-end or an adjustable wrench



Flavorizer Bars - 5



Cooking Grates - 2

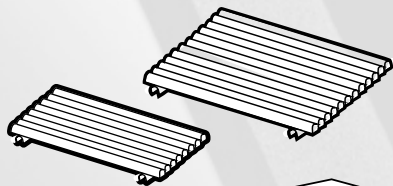

Smoker Box - 1

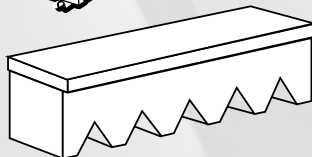

Bottom Shelf - 1

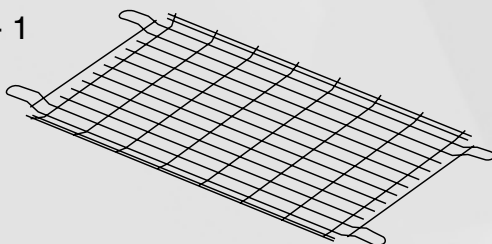

Slide Out Bottom Tray - 1

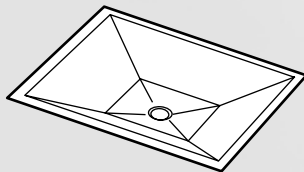

Catch pan holder - 1



Catch Pan - 1



Disposable Drip Pans - 2



1/2 inch bolts (1/4 x 20 x 1/2 inch bolts) - 4

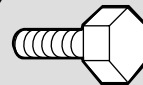

Nylon Washers - 4



Left Work Surface - 1

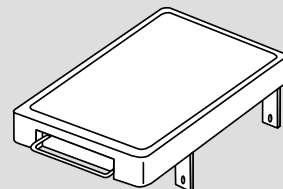

Right Work Surface with Side Burner - 1

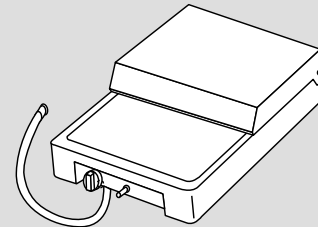

12 Foot Hose - 1

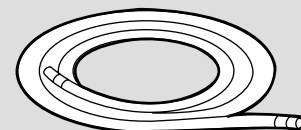



Unpacking

Remove Packaging from Grill

Remove all tape from packaging. Remove bottom rack from top of packaging. Remove outer box. Pull out bottom tray from cooking box. Remove packaging material from bottom tray, catch pan holder, catch pan, and drip pan.

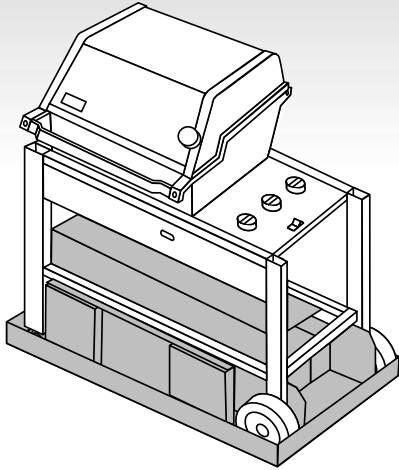

Remove Grill from Lower Packaging

⚠ WARNING: Lifting the barbecue from the lower packaging requires at least two people.
With two people: lift straight up and over lower packaging and cardboard support.

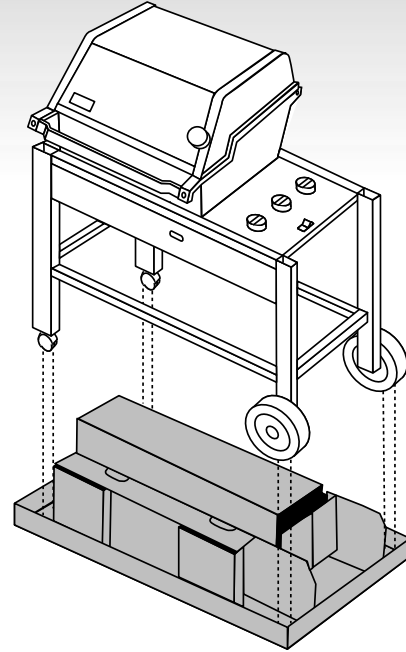



Install the slide out bottom tray

You will need: the slide out bottom tray(1), catch pan holder(2), catch pan and one disposable drip pan.

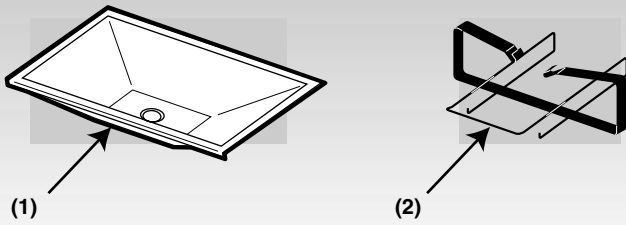

Hook the ends of the catch pan holder into the hole in the slide out bottom tray. **The front of the catch pan holder must be on the same side as the finger grip(1) of the bottom tray.**

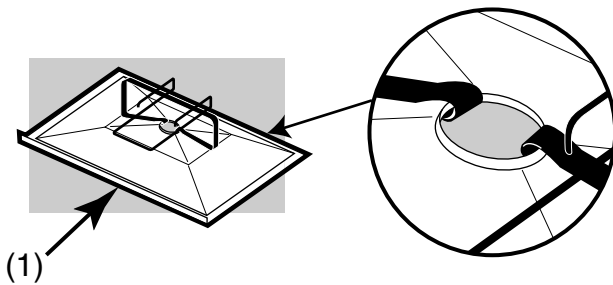

Slide the bottom tray onto the mounting rails under the cooking box with finger grip toward you(1).

⚠ WARNING: Do not line bottom tray with aluminum foil. It can cause grease fires by trapping the grease and not allowing grease to flow into the catch pan.

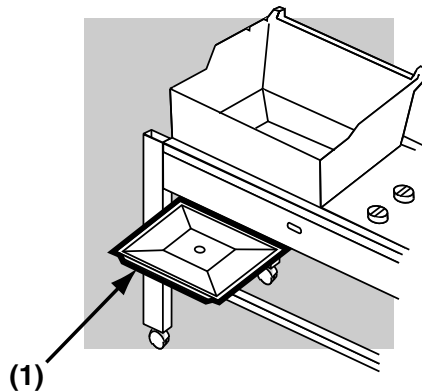

Put the disposable drip pan into the catch pan.

Slide the catch pan into the catch pan holder with its finger grip towards you(1).

Install Flavorizer® Bars and Cooking Grates

You will need: five Flavorizer Bars and two cooking grates. Place the Flavorizer Bars side by side in the cooking box.

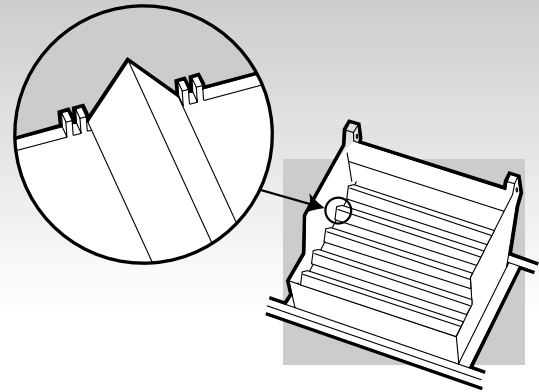

Set the cooking grates onto the ledges in the cooking box with the rounded sides up.

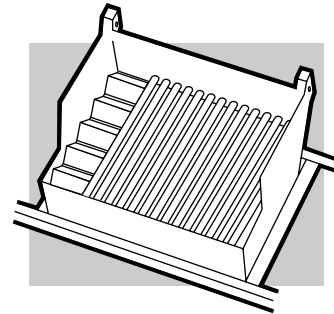

Installing Smoker Box

Place Smoker box on the flavorizer Bars between the cooking grate and the inside of the cooking box. The lid should open toward the cooking grates.

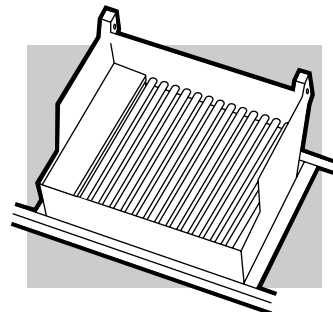



Installing the Warm-Up™ Basket

You will need: Warm-Up Basket

Insert one end of the Weber Warm-Up Basket into the hole at the right side of the inside of the lid, and the other end into the slot at the left side of the lid.

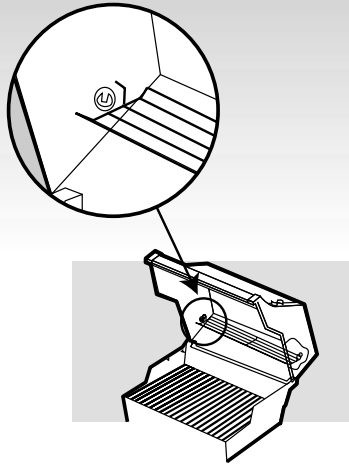

Installing the warming rack

You will need: warming rack.

Set the warming rack into the slots at the rear of the cooking box.

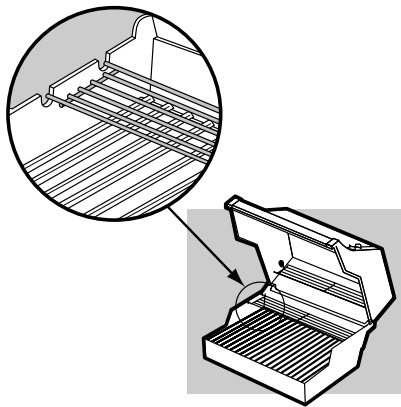

Install the bottom shelf

You will need: Bottom shelf.

Set the bottom shelf in place between the two frame connectors underneath the cooking box.

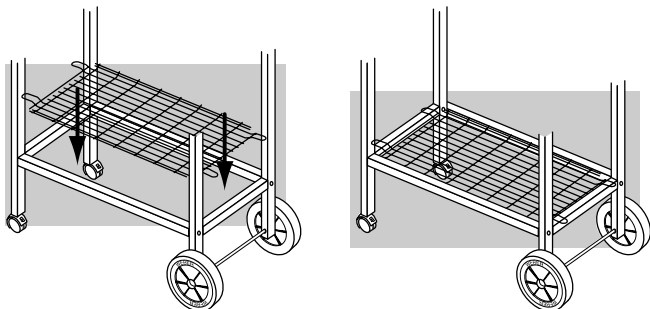

Install Left Work Surface

You will need left work surface, two 1/2 inch bolts, two nylon washers and a 7/16 inch or adjustable wrench. Insert the left work surface tabs in the slots in the frame(1). Slip washers on the bolts and insert the bolts as shown(2). Tighten

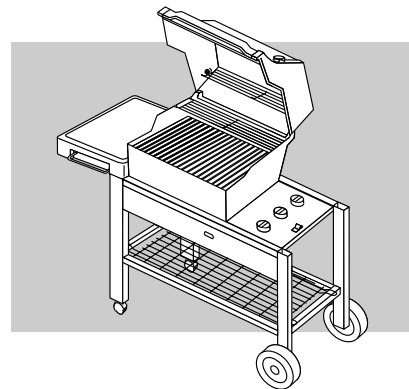
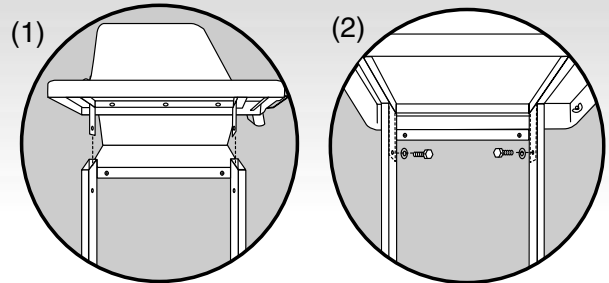

Check that all burner valves are off

You will need: burner control knobs.

Valves are shipped in the OFF position, but you should check to be sure that they are turned OFF. Put the knob on each valve. Check by pushing down and turning clockwise. If they do not turn, they are off. Proceed to the next step. If they do turn continue turning them clockwise until they stop, then they are off. Proceed to the next step.

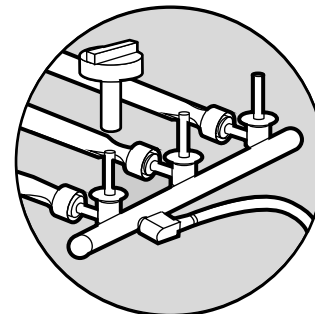

Check that the side burner valve is in the OFF position. Push in and turn to OFF.

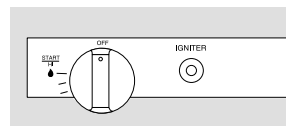



Install Side Burner Assembly

You will need side burner assembly (assembly includes mounting frame), two 1/2 inch bolts, two nylon washers and a 7/16 inch or adjustable wrench.

Note: Remove protective covers from tabs of side burner
Insert the side burner tabs in the slots of the frame(1). Slip washers on the bolts and insert the bolts as shown(2). Tighten bolts with wrench.

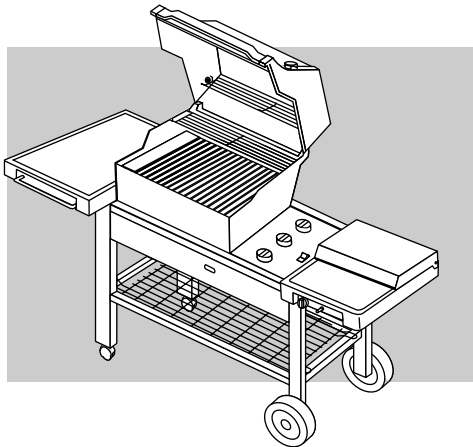
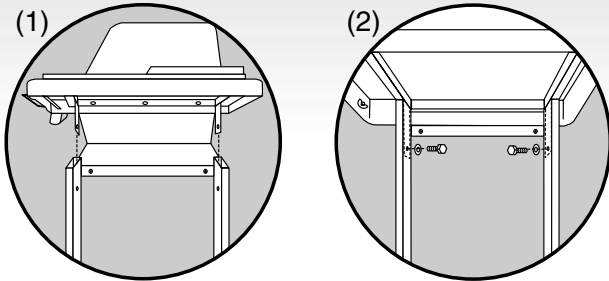

Check that the side burner is properly assembled.

- 1) Windshield
- 2) Grate
- 3) Burner cap
- 4) Burner ring
- 5) Lugs
- 6) Slots
- 7) Igniter electrode
- 8) Burner head
- 9) Burner base
- 10) Burner orifice

⚠WARNING: Set the side burner ring onto the side burner head. Rotate the burner ring until the four lugs on the burner ring are seated in the four slots on the burner head.

Note: The burner head has a hole in it that fits over the igniter electrode.

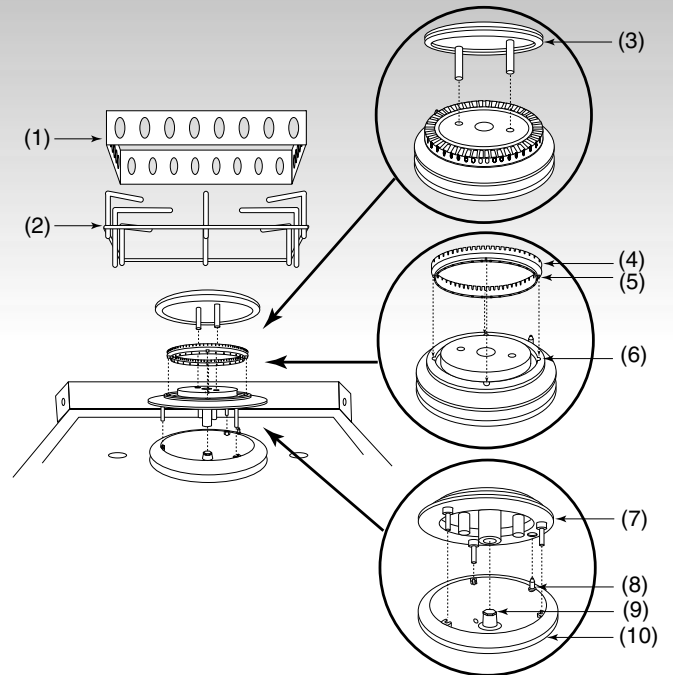

Connect side burner to manifold

⚠ WARNING: Make sure gas supply is off.

Connect the side burner hose as follows:

- 1) Slide back the collar of the quick disconnect on the manifold.
- 2) Push the male fitting of the side burner hose into the quick disconnect, and maintain pressure. Slide the collar closed.

Quick disconnect will be engaged.

Check to be sure the side burner valve is OFF. Push the side burner control knob down and turn it clockwise. If it doesn't turn, the valve is OFF. If it does turn, continue turning it clockwise until it stops, then the burner valve is OFF.

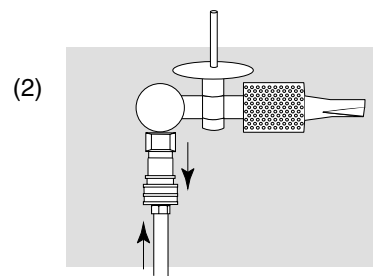
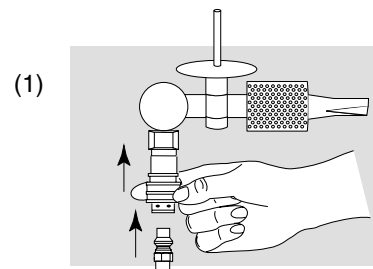

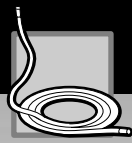

Gas Instructions

Install Gas Supply

General Specifications for Piping

Note - Contact your local municipality for building codes regulating outdoor gas barbecue installations. In absence of Local Codes, you must confirm to the latest edition of ANSI Z223.1. WE RECOMMEND THAT THIS INSTALLATION BE DONE BY A PROFESSIONAL.

Some of the following are general requirements taken from ANISI Z223.1 latest edition for complete specifications.

- This barbecue is designed to operate at 7 inches of water column pressure (.2526 psi).
- A manual shut-off valve must be installed outdoors, immediately ahead of the quick disconnect.
- An additional manual shut-off valve indoors should be installed in the branch fuel line in an accessible location near the supply line
- The quick disconnect connects to a 3/8 inch NPT thread from the gas source. The quick disconnect fitting is a hand-operated device that automatically shuts OFF the flow of gas from the source when the barbecue is disconnected
- The quick disconnect fitting can be installed horizontally, or pointing downward. Installing the fitting with the open end pointing upward can result in collecting water and debris.
- The dust covers (supplied plastic plugs) help keep the open ends of the quick disconnect fitting clean while disconnected.
- Pipe compound should be used which is resistant to the action of natural gas when connections are made.
- The outdoor connector must be firmly attached to rigid, permanent construction.

⚠ WARNING: Do not route the 12 foot hose under a deck. The hose must be visible.

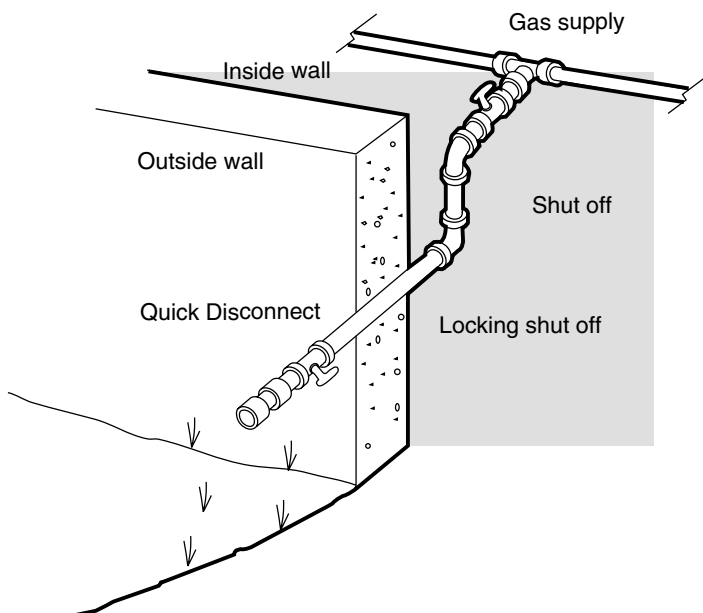

Gas Line Piping

- If the length of the line required does not exceed 50 feet, use a 5/8" O.D. tube. One size larger should be used for lengths greater than 50 feet.
- Gas piping may be copper tubing, type K or L; polyethylene plastic tube, with a minimum wall thickness of .062 inch; or standard weight (schedule 40) steel or wrought iron pipe.
- Copper tubing must be tin-lined if the gas contains more than 0.3 grams of hydrogen sulfide per 100 cubic feet of gas.
- Plastic tubing is suitable only for outdoor, underground use.
- Gas piping in contact with earth, or any other material which may corrode the piping, must be protected against corrosion in an approved manner.
- Underground piping must have a minimum of 18" cover

Test Connections

All connections and joints must be thoroughly tested for leaks in accordance with local codes and all listed procedures in the latest edition of ANSI Z223.1

⚠ DANGER

Do not use an open flame to check for gas leaks. Be sure there are no sparks or open flames in the area while you check for gas leaks. This will result in a fire or explosion which can cause serious bodily injury or death and damage to property.



Gas Instructions

Check that all burner valves are off

Valves are shipped in the OFF position, but you should check to be sure that they are turned OFF. Check by pushing down and turning clockwise. If they do not turn, they are off. Proceed to the next step. If they do turn continue turning them clockwise until they stop, then they are off. Proceed to the next step.

Check the flexible hose to manifold connection

See Page C-3

The Natural gas hose has been attached during the manufacturing process. We do recommend that the hose to gas manifold connection be leak tested, following guidelines in this Owners Guide, prior to barbecue operation.

Check:

- 1) Hose to manifold connection.

⚠ WARNING: If there is a leak a connection(1), retighten the fitting with a wrench and recheck for leaks with soap and water solution.

If a leak persists after retightening the fitting, turn OFF the gas. DO NOT OPERATE THE GRILL. Contact the Customer Service Representative in your region using the contact information sheet provided with your manual.

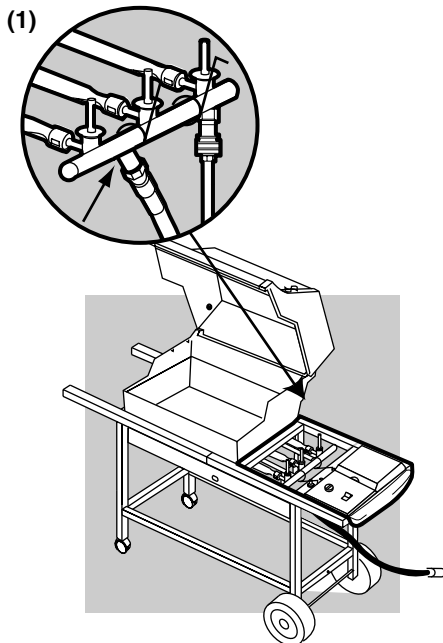

*The grill illustrated may have slight differences than the model purchased.

Check for gas leaks

⚠ WARNING: The gas connections of your Weber gas barbecue have been factory tested. We do however recommend that you leak check all gas connections before operating your Weber gas barbecue.

⚠ WARNING: Perform these leak checks even if your barbecue was dealer or store assembled.

- 1) Unscrew the two phillips screws, located on the right edge of the control panel.

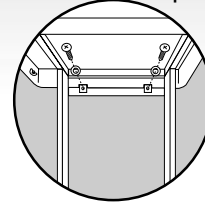

- 2) Take off the burner control knobs.

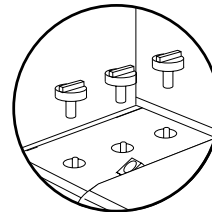

- 3) Lift off the control panel.

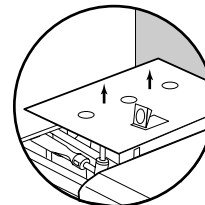

⚠ DANGER

Do not use an open flame to check for gas leaks. Be sure there are no sparks or open flames in the area while you check for leaks. Sparks or open flames will result in a fire or explosion, which can cause serious bodily injury or death and damage to property.

⚠ WARNING: You should check for gas leaks every time you disconnect and reconnect a gas fitting.

You will need: A soap and water solution and a rag or brush to apply it.

Note: Since some leak test solutions, including soap and water, may be corrosive, all connections should be rinsed with water after checking for leaks.

⚠ WARNING: Make sure all burner control knobs are in the OFF position, including the side burner.



Gas Instructions

Check for gas leaks

Note - All factory-made connections have been thoroughly checked for gas leaks. The burners have been flame-tested. As a safety precaution however, you should recheck all fittings for leaks before using your Weber Gas Barbecue. Shipping and handling may loosen or damage a gas fitting.

To perform leak checks: Slide back the collar of the quick disconnect. Push male fitting of the hose into the quick disconnect, and maintain pressure(1). Slide the collar closed(2). If it does not engage or lock, repeat procedure. Gas will not flow unless the quick disconnect is properly engaged.

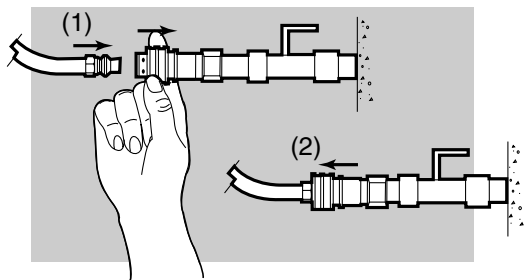

Turn on gas supply.

⚠WARNING: Do not ignite burners while checking for leaks.

Check for leaks by wetting the connections with the soap and water solution and watching for bubbles. If bubbles form or if a bubble grows, there is a leak.

Check:

1) Hose to manifold connection.

⚠WARNING: if there is a leak at connection(1), retighten the fitting with a wrench and recheck with the soap and water solution

If a leak persists after retightening the fitting, turn OFF the gas. DO NOT OPERATE THE BARBECUE. Contact the Customer Service Representative in your region using the contact information sheet provided with your manual.

2) Manifold to side burner hose connection.

3) Valves to manifold connections.

4) Hose to quick disconnect connection.

5) Side burner supply line to side burner orifice connection. (view from below)

6) Side burner hose to side burner valve, and side burner supply line to side burner valve. (view from below)

⚠WARNING: If there is a leak at connections 2,3,4,5 or 6 turn OFF the gas. DO NOT OPERATE THE BARBECUE. Contact the Customer Service Representative in your region using the contact information sheet provided with your manual.

When leak checks are complete, turn gas supply OFF at the source and rinse connections with water.

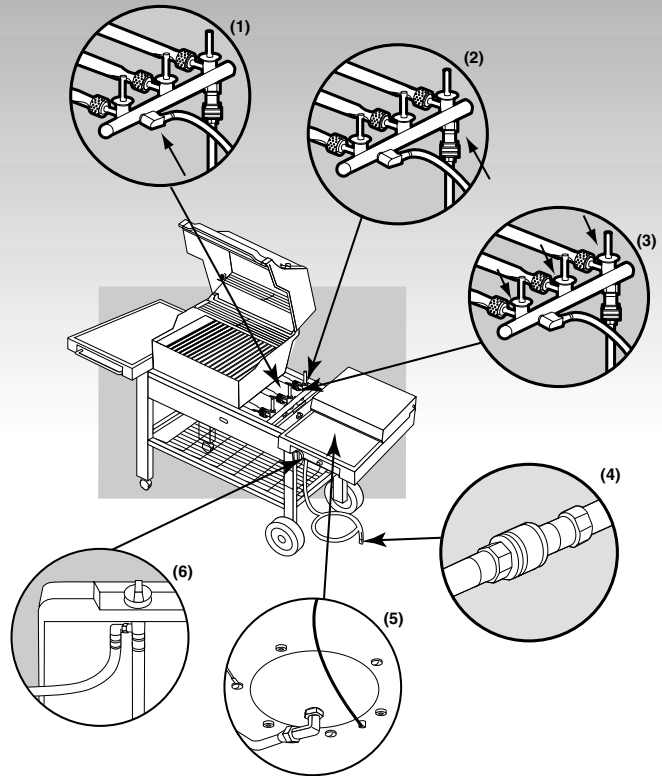

Reinstall control panel (after checking for gas leaks)

(1) Set the control panel in place over both sides of the frame. Hold the crossover ignition button up while setting the control panel in place.

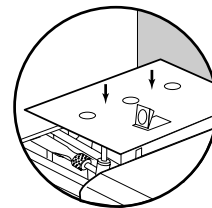

(2) Line up the control panel with the white plastic plugs in the frame brace. Insert screws and tighten with a Phillips screwdriver until snug. Do not overtighten.

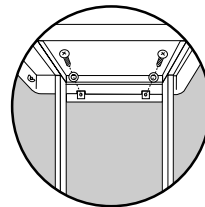

(3) Push each of the burner control knobs onto their valve.

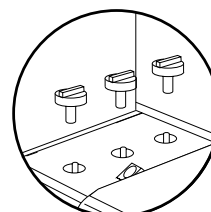

(4) Reinstall Side Burner cover.



Operating Instructions

Lighting

Summary lighting instructions are on the control panel.

⚠ DANGER

Failure to open the lid while igniting the barbecue's burners, or not waiting 5 minutes to allow the gas to clear if the barbecue does not light, may result in an explosive flame-up which can cause serious bodily injury or death.

Crossover® Ignition System

Note - The Crossover® ignition system ignites the Front burner with a spark from the igniter electrode inside the Gas Catcher™ ignition chamber. You generate the energy for the spark by pushing the Crossover® ignition button until it clicks.

⚠ **WARNING:** Check hose before each use of barbecue for nicks, cracking, abrasions or cuts. If the hose is found to be damaged in any way, do not use the barbecue. Replace using only Weber authorized replacement hose. Contact the Customer Service Representative in your region using the contact information sheet provided with your manual.

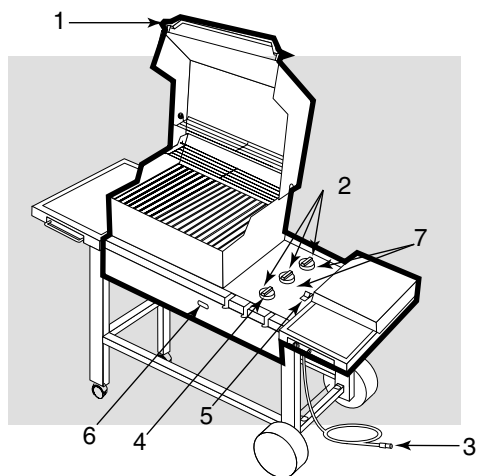

*The grill illustrated may have slight differences than the model purchased.

- 1) Open the lid.
- 2) Make sure all burner control knobs are turned OFF. (Push each burner control knob down and turn clockwise to ensure that they are in the off position.)
- 3) Turn the gas supply valve on.
⚠ **WARNING:** Do not lean over the open barbecue. Keep your face and body at least one foot away from the matchlight hole when lighting the barbecue.
- 4) Push Front burner control knob down and turn to START/HI.
- 5) Push the Crossover Ignition Button several times, so it clicks each time.
- 6) Check that the burner is lit by looking through the matchlight hole on the front of the cooking box. You should see flame.
⚠ **WARNING:** If the burner does not light, turn the Front burner control knob to OFF and wait 5 minutes to let the gas clear before you try again, or try to light with a match.
- 7) After the FRONT burner is lit you can turn on the other burner or burners.

Note - Always light the FRONT burner first. The other burner or burners ignite from the FRONT burner.

To Extinguish

Push down and turn each burner control knob clockwise to the OFF position. Turn gas supply OFF at the source.



Operating Instructions

Manual Lighting

⚠ DANGER

Failure to open lid while igniting the barbecue's burners, or not waiting 5 minutes to allow the gas to clear if the barbecue does not light, may result in an explosive flame-up which can cause serious bodily injury or death.

- 1) Open the lid.
 - 2) Make sure all burner control knobs are turned OFF. (Push each burner control knob down and turn clockwise to ensure they are in the off position.)
 - 3) Turn the gas supply valve on.
 - 4) Strike a match and put the flame into the matchlight hole in the front of the cooking box.
- ⚠ **WARNING: Do not lean over the open barbecue. Keep your face and body at least one foot away from the matchlight hole when lighting the barbecue.**
- 5) Push Front burner control knob down and turn to START/HI.
 - 6) Check that the burner is lit by looking through the matchlight hole on the front of the cooking box. You should see a flame.
- ⚠ **WARNING: If the burner does not light, turn the Front burner control knob to OFF and wait 5 minutes to let the gas clear before you try again or try to light with a match.**
- 7) After the FRONT burner is lit you can turn on the other burner or burners.

Note - Always light the FRONT burner first. The other burner or burners ignite from the FRONT burner.

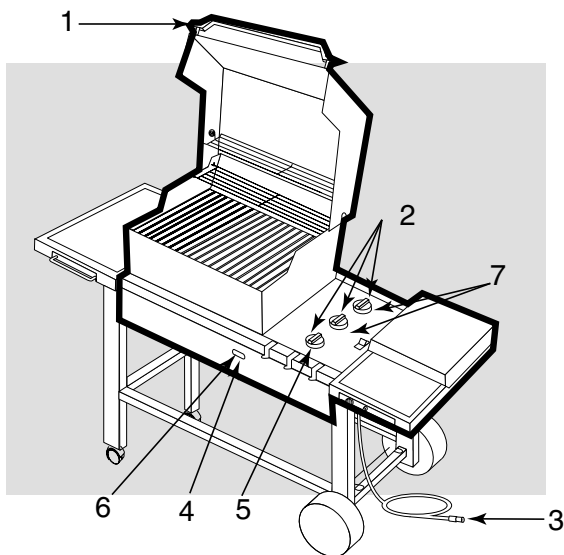

*The grill illustrated may have slight differences than the model purchased.

To Extinguish

Push down and turn each burner control knob clockwise to the OFF position. Turn gas supply OFF at the source.



Operating Instructions

Lighting the Side Burner

The side burner has a separate ignition system from the main cooking box.

⚠ DANGER

Failure to open the lid while igniting the side burner, or not waiting 5 minutes to allow the gas to clear if the side burner does not light, may result in an explosive flame-up which can cause serious bodily injury or death.

Lighting only the side burner.

- 1) Open the side burner lid.
- 2) Check that the side burner valve is turned OFF. (Push each knob down and turn clockwise to ensure they are in the off position.), and all main burner control valves are OFF (push down and turn clockwise).
- 3) Turn the LP tank valve on (turn counter-clockwise).
- 4) Push down and turn the side burner control valve to HI.
- 5) Push the side burner igniter button several times so it clicks each time.

⚠ **CAUTION:** Side burner flame may be difficult to see on a bright sunny day.

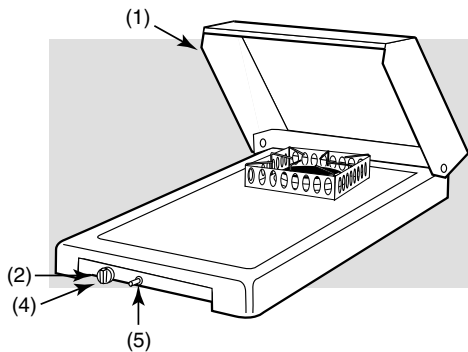

⚠ **WARNING:** If the side burner does not light:

- 1) Turn OFF the side burner control valve.
- 2) Wait 5 minutes to let the gas clear before you try again or try to light with a match.

Lighting the side burner if the main burners are lit.

- 1) Open the side burner lid.
- 2) Push down and turn the side burner control to HI.
- 3) Press the side burner igniter button several times so it clicks each time.

⚠ **CAUTION:** Side burner flame may be difficult to see on a bright sunny day.

⚠ **WARNING:** If the side burner does not light:

- 1) Turn OFF the side burner control valve.
- 2) Wait 5 minutes to let the gas clear before you try again or try to light with a match.



Troubleshooting

Problem	Check	Cure
Burners burn with a yellow or orange flame, in conjunction with the smell of gas.	Inspect Weber® Spider Stopper™ Guard for possible obstructions. (Blockage of holes.)	Clean Weber® Spider Stopper™ Guard. (See Section “Annual Maintenance”)
Burner does not light, or flame is low in HIGH position.	Is fuel hose bent or kinked?	Straighten fuel hose.
	Does the Front burner light with a match?	If you can light the Front burner with a match, then check the Crossover® ignition system.
Experiencing flare-ups: ⚠ CAUTION: Do not line the bottom tray with aluminum foil.	Are you preheating barbecue in the prescribed manner?	All burners on high for 10 to 15 minutes for preheating.
	Are the cooking grates and Flavorizer® bars heavily coated with burned-on grease?	Clean thoroughly. (See Section “Cleaning”)
	Is the bottom tray “dirty” and not allowing grease to flow into catch pan?	Clean bottom tray
Burner flame pattern is erratic. Flame is low when burner is on HIGH. Flames do not run the whole length of the burner tube.	Are burners clean?	Clean burners. (See Section “Maintenance”.)
Inside of lid appears to be “peeling.” (Resembles paint peeling.)	The lid is porcelain-on-steel, not paint. It cannot “peel”. What you are seeking is baked on grease that has turned to carbon and is flaking off. THIS IS NOT A DEFECT.	Clean thoroughly. (See Section “Cleaning”.)
If problems cannot be corrected by using these methods, please contact the Customer Service Representative in your region using the contact information sheet provided with your manual.		



Side Burner Troubleshooting

Problem	Check	Cure
Side Burner does not light.	Is gas supply off?	Turn supply on.
Flame is low in HIGH position.	Is the fuel hose bent or kinked?	Straighten hose.
Flame is very yellow in conjunction with the smell of gas, OR Burner makes popping noise in conjunction with the smell of gas.	Inspect the Weber® Spider Stopper™ Guard for possible obstructions. (lockage of holes.)	Clean Weber® Spider Stopper™ Guard (See section “Annual Maintenance”)
Push button ignition does not work.	Does burner light with a match?	If match lights burner, check igniter (see below).

Side Burner Maintenance

⚠WARNING: All gas controls and supply valves should be in the OFF position.

Make sure black wire is connected between igniter and electrode. Make sure white wire is connected between igniter and ground. Check that igniter lock nut is tight.

Note - If the igniter works loose, carefully tighten the igniter lock nut with an adjustable wrench or pliers.

- 1) Burner Control Knob
- 2) Igniter Button
- 3) Igniter Lock Nut
- 4) White Wire
- 5) Ground
- 6) Black Wire
- 7) Electrode

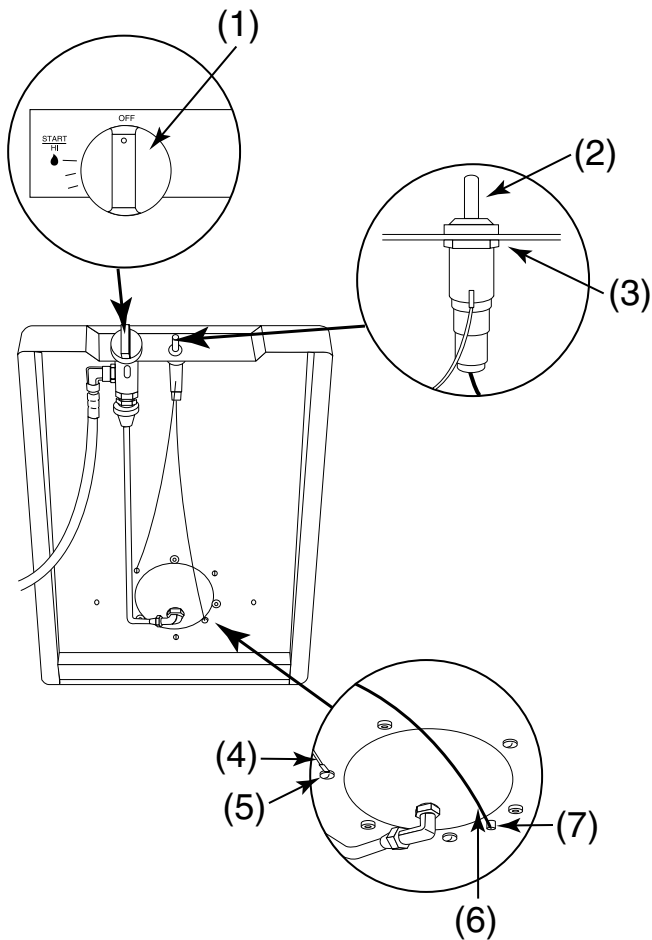

The Platinum Series II side burner has been factory set for the correct air and gas mixture. The correct flame pattern is shown.

- 1) Tips occasionally flicker yellow
- 2) Light blue
- 3) Dark blue

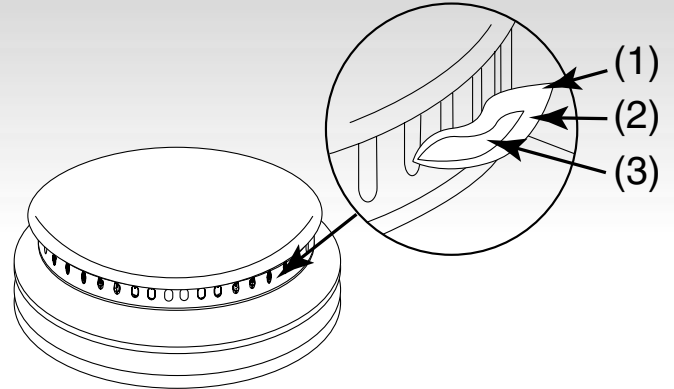

Side Burner Maintenance

To Clean the Burner Head

Remove the windshield and grate. Remove the burner cap. Clean with soap and water. Soak if necessary.

Remove the burner ring. Clean with soap and water. Soak if necessary.

⚠CAUTION: Do not enlarge the slots in the burner ring. Only clean with a cloth and soap and water.

Remove the burner head. Clean with soap and water. Soak if necessary.

Wipe out the burner base with a damp cloth and soap and water.

⚠CAUTION: Avoid getting water or dust in the burner orifice.

Clean the ignition electrode with a damp cloth and soap and water.

- 1) Windshield
- 2) Grate
- 3) Burner Cap
- 4) Burner Ring
- 5) Lug
- 6) Slots
- 7) Burner Head
- 8) Igniter electrode
- 9) Burner Orifice
- 10) Burner Base

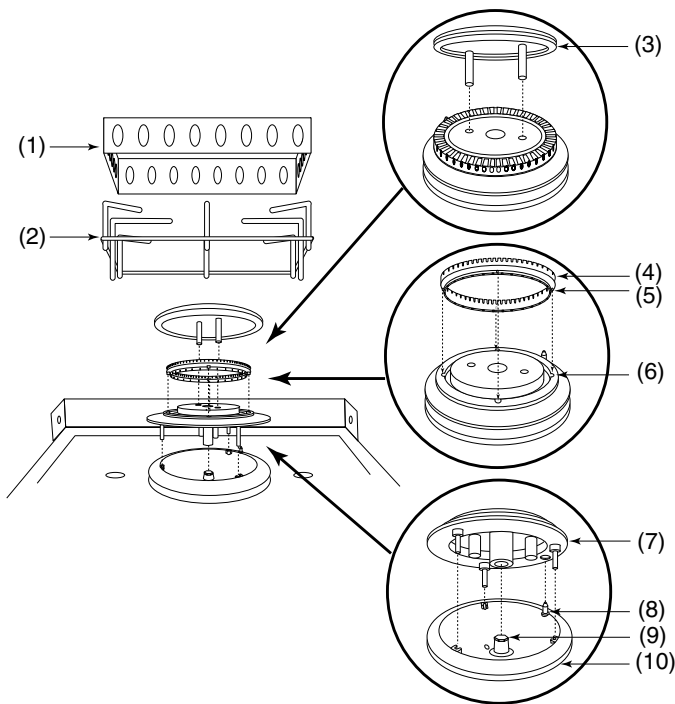

To Reassemble the Burner Head

Insert the burner head into the burner base. Figure 19 (c). There is a hole in the burner head for the igniter electrode.

Set the burner ring onto the burner head. Rotate the burner ring until the four lugs on the burner ring are seated in the four slots on the burner head. Figure 19 (b).

⚠WARNING: If the flame pattern is uneven or erratic, turn OFF the burner control knob. Check the position of the burner ring to the burner head. The lugs of the burner ring must be in the slots of the burner head.

Install the burner cap. Figure 19 (a). Install the grate and the windshield.

- 1) Windshield
- 2) Grate
- 3) Burner Cap
- 4) Burner Ring
- 5) Lug
- 6) Slot
- 7) Burner Head
- 8) Igniter Electrode
- 9) Burner Base
- 10) Burner Orifice

Burner assembly consists of: burner cap, burner ring, burner head, burner base, and burner orifice.

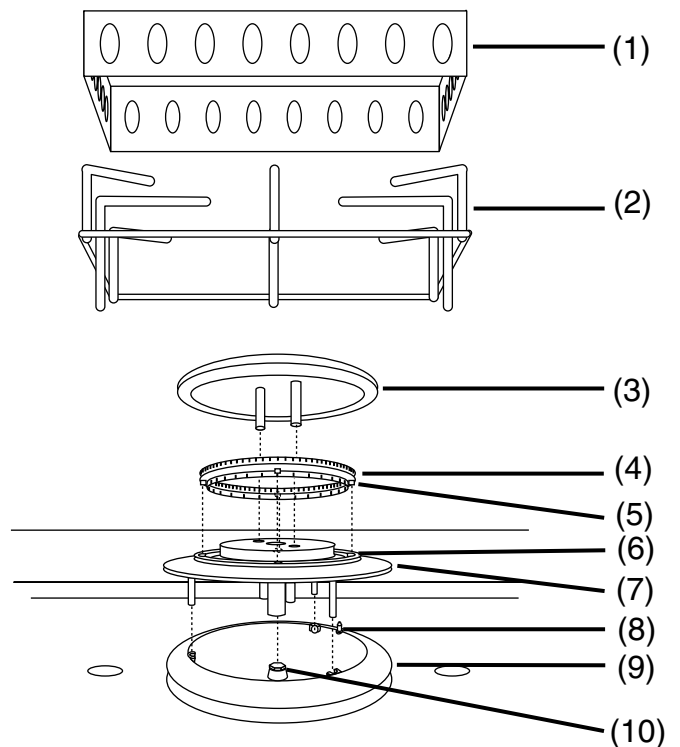

Note: The burner head has a hole in it that fits over the igniter electrode.

Maintenance

General Maintenance

Weber Spider Stopper™ Guards

Your Weber Gas Barbecue, as well as any outdoor gas appliance, is a target for spiders and other insects. They can nest in the venturi section (Venturi(1), air shutter(2), venturi fin(3)) of the burner tubes. This blocks the normal gas flow, and can cause the gas to flow back out of the air shutter. This could result in a fire in and around the air shutters, under the control panel, causing serious damage to your barbecue.

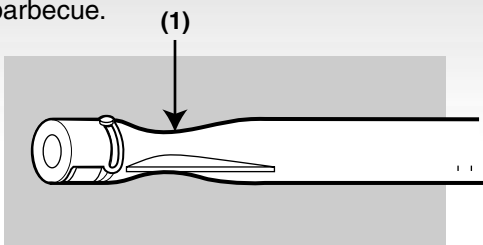

The Weber Spider Stopper™ Guard(1) is factory installed. It fits tightly around the air shutter section of the burner tube and the valve, thereby preventing spiders and other insects access to the burner tubes through the air shutter openings.

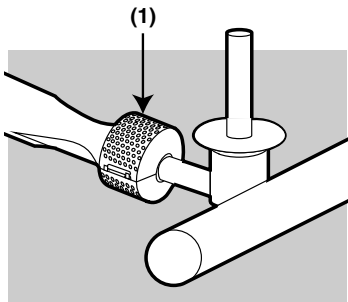

We recommend that you inspect the Weber Spider Stopper™ Guards at least once a year. (See Section “Annual Maintenance”.) Also inspect and clean the Spider Stopper Guards if any of the following symptoms should ever occur:

- 1) The smell of gas in conjunction with the burner flames appearing yellow and lazy.
- 2) Barbecue does not reach temperature.
- 3) Barbecue heats unevenly.
- 4) One or more of the burners do not ignite.

⚠DANGER

Failure to correct the above mentioned symptoms may result in a fire, which can cause serious bodily injury or death, and cause damage to property.

Annual Maintenance

Inspection and Cleaning of the Weber Spider Stopper™ Guards

To inspect the Spider Stopper Guards, remove the control panel and look to see if they have dust or dirt on their

E204.a

outside surfaces. If they are dirty, brush off the outside surface of the Spider Stopper Guards with a soft bristle brush (an old toothbrush for example). Check that there are no gaps in the Spider Stopper Guards’ seams or in the fit around the burners or valves. (See Section “General Maintenance.”)

Main Burner Flame Pattern

The Weber® gas barbecue burners have been factory set for the correct air and gas mixture. The correct flame pattern is shown.

- 1) Burner tube
- 2) Tips occasionally flicker yellow
- 3) Light blue
- 4) Dark blue

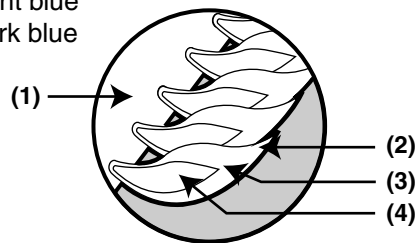

If the flames do not appear to be uniform throughout the burner tube, follow the burner cleaning procedures.

Main Burner Cleaning Procedure

Turn off the gas supply. Remove the manifold. Look inside each burner with a flashlight.

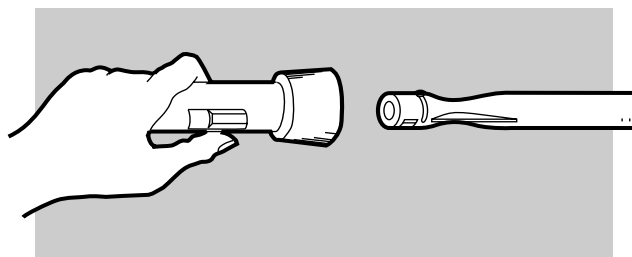

Clean the inside of the burners with a wire (a straightened-out coat hanger will work). Check and clean the air shutter opening at the ends of the burners. Check and clean the valve orifices at the base of the valves. Use a Steel bristle brush to clean outside of burners. This is to make sure all the burner ports are fully open.

⚠CAUTION: Do not enlarge the burner ports when cleaning.

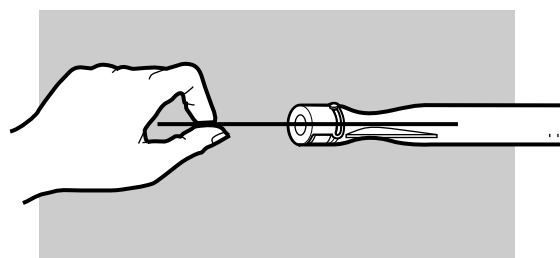

Maintenance

Replacing Main Burners

- 1) Your Weber Gas Barbecue must be OFF and cool.
- 2) Turn gas OFF at source.
- 3) To remove control panel: take off the burner control knobs. Remove the screws holding the control panel in place. Lift off the control panel.
- 4) Unlatch the Spider Stopper™ Guards and remove them.

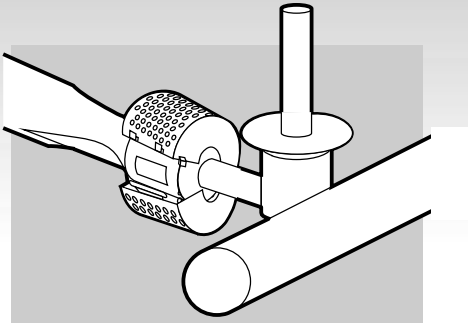

- 5) Remove the manifold bracket and unscrew the two wing nuts(1) that hold the manifold to the cooking box. Pull the manifold and valve assembly out of the burners and carefully set it down.

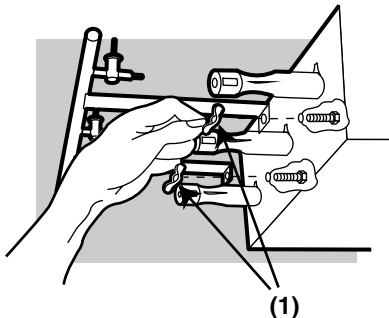

- 6) Slide the burner assembly out from under the guide screw and washer(1) in the corners of the cooking box.

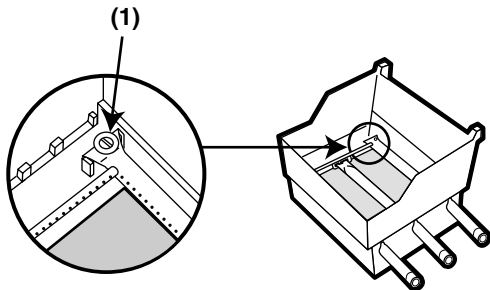

- 7) Lift and twist the burner assembly slightly, to separate the crossover tube(1) from the burners. Remove the burners from the cooking box.

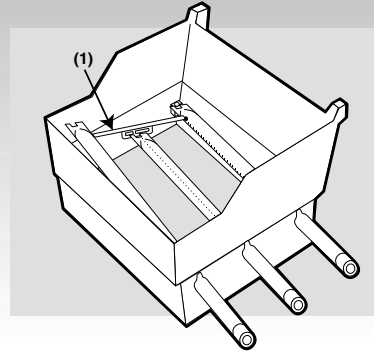

- 8) To reinstall the burners, reverse 3) through 7).
⚠ CAUTION: The burner openings(1) must be positioned properly over the valve orifices(2).
Check proper assembly before fastening manifold in place.

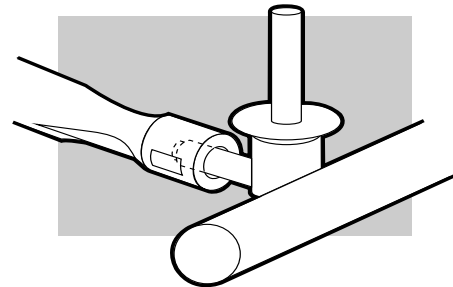
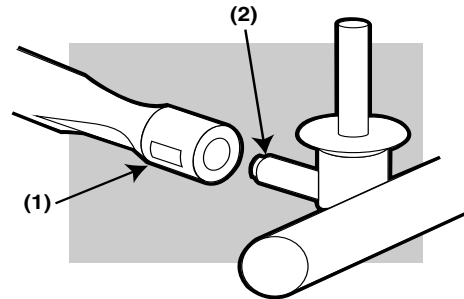

Maintenance

- 9) Reinstall the Spider Stopper Guards. Slightly rotate the Spider Stopper Guards so that the seams are in line with the Venturi fins(1). There should be no gaps in the seams or in the fit around the burners(2) and valves(3).

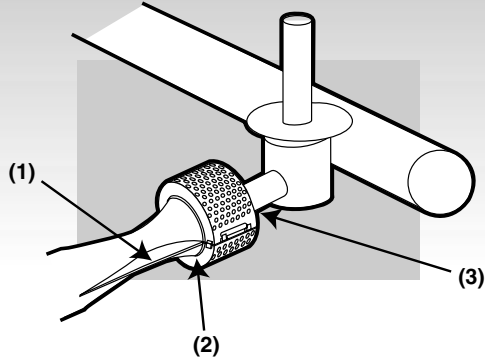

⚠ **CAUTION:** If the Spider Stopper Guards do not fit tightly, contact the Customer Service Representative in your region using the contact information sheet provided with your manual.

⚠ **WARNING:** After reinstalling the gas lines, they should be leak checked with a soap and water solution before using the barbecue. (See Step: "Check for gas leaks.")

Crossover® Ignition System Operations

If the Crossover Ignition System fails to ignite the Left burner, light the Left burner with a match. If the Left burner lights with a match, then check the Crossover Ignition System.

■ Check that both the white(1) and black(2) ignition wires are attached properly.

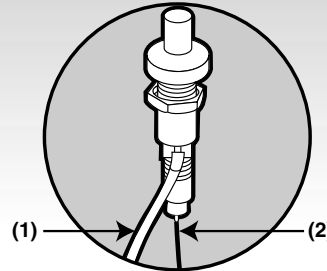

■ Check that the Crossover Ignition button pushes the igniter (button) down, and returns to the up position.

■ Check to see if the igniter is loose in the frame. Tighten if necessary; See Step "Install igniter" for correct procedure. If the Crossover Ignition System still fails to light, Contact the Customer Service Representative in your region using the contact information sheet provided with your manual.